



E26800-00
E26900-00



GENESYS™ SERIES

20" Transaxle Drive
Automatic Scrubber



Operator and Parts
Manual

TABLE OF CONTENTS

Specifications	3
Safety Information	4
Machine Preparation: Unpacking	5
Transporting the Machine: Tie Down Procedure	6
Batteries	7 - 9
Charging	10
Machine Preparation / Setup	11
Machine Operational Controls	12 - 13
Drive System	14
Disk Machine Pad Driver and Brush	15
Orbital Machine Pad	16
Recovery System	17 - 18
Squeegee Assembly	19 - 20
SoliChem™ Solution Distribution System	21
Fortify™ ARMOR™ Telemetry	22
Fortify™ Programmable Timer Lock-out	23
Parts Diagrams and Listings	24 - 59
Recommended Service Parts List	60
Recommended Maintenance	61
Trouble Shooting Guide	62
Warranty	64

SPECIFICATIONS

Specifications	GeneSys™ 20DT	GeneSys™ 20ORB
Productivity (sq. ft./hour)	Up to 22,500	Up to 22,500
Cleaning Pad Width	20 in. Disk	20x14 in. Orbital
Pad / Brush Dimensions	(1) 20 in. Disk	(1) 20x14 in. Orbital
Brush Motor(s)	1.0 HP	.75 HP
Pad Speed	230 RPM	2,200 RPM
Down Pressure	60, 80, 100 lbs.	60, 85, 110 lbs.
Solution Tank	13 gal.	13 gal.
Recovery Tank	15 gal.	15 gal.
Solution Flow	0 - 0.5 gpm	0 - 0.5 gpm
Battery Option (2x 12V)	130, 150 AH Wet 110 AH AGM	130, 150 AH Wet 110 AH AGM
Run Time	Up to 3.5 hr.	Up to 3.5 hr.
Sound Level	<65 dBa	<65 dBa
Vac Motor / Filter	0.62 HP / HEPA	0.62 HP / HEPA
Machine Weight (w/ Largest Battery Option)	425 lbs.	425 lbs.
Machine Dimensions	51 x 21 x 42 in.	46 x 21 x 42 in.
Squeegee Width	30 in.	30 in.
Warranty*	Rotomold - 10 years Parts/Labor - 3 years Travel - 180 days Batteries - 1 year (pro-rated) Charger - 1 year	Rotomold - 10 years Parts/Labor - 3 years Travel - 180 days Batteries - 1 year (pro-rated) Charger - 1 year
*See full warranty for details		

Key Options & Accessories

Fortify™ Wet Battery Protection System
 Fortify™ Programmable timer Lock-out
 Fortify™ Armor Telemetry & Reporting
 Fortify™ Foam Control
 Brush: General Purpose

SoliChem™ Chemicals: Daily: pH7 Ultra
 Degreaser: EnviroZyme® Grease Solv

For more information on the available options and accessories for your machine, contact your nearest authorized Betco® equipment representative.



SAFETY INFORMATION



The safety instructions and guidelines below must be carefully followed in order to avoid harm to the operator and damage to the machine.

- Read all labels on the machine carefully. Do not cover labels for any reason and replace damaged labels immediately.
- Before using the machine, make sure that all doors and covers are positioned as shown in this manual.
- Never remove guards that require tools for removal.
- The power cable outlet must be provided with a proper ground.
- The machine must be used exclusively by authorized and trained personnel.
- The operator must always use appropriate personal protective equipment (gloves, shoes, helmet, glasses, etc.)
- When operating the machine, the operator must be careful of people and obstructions in the surrounding area.
- Machine operating conditions are room temperature between 33°F and 100°F with relative humidity between 30% to 95%.
- Only use the machine in closed areas and do not expose it directly to rain.
- Never use the machine in an explosive environment.
- Never vacuum up flammable liquids.
- Never use the machine to gather dangerous powders.
- In the case of fire, use a powder fire extinguisher. Do not use water.
- When appropriate, use suitable signs to warn others of the presence of wet floors.
- The machine is not designed for cleaning carpets.
- Avoid running the brushes with the machine stopped; doing so may damage the floor.
- Do not hit against shelving or scaffolding.
- Avoid damaging the power cable of the battery charger from crushing, bending, cutting or stressing it.
- Whenever the power cable of the battery charger is damaged, immediately contact a BETCO® service center.
- Do not use the machine on surfaces with an inclination greater than the one shown on the serial plate.
- Do not use the machine as a means of transport.
- Do not set containers on the machine.
- Machine storage temperature is between -10°F and 130°F, never store outside under humid conditions.
- To prevent the formation of scale in the solution tank filter, do not store the machine with detergent solution in the tanks.
- Never wash the machine with direct or pressurized jets of water or with corrosive substances.
- Do not mix different types of detergent as this may produce harmful gases.
- Never use acidic chemicals which could damage the machine.
- If the machine does not work properly, perform routine maintenance. Otherwise, contact BETCO Technical Support.
- Whenever maintenance is performed, always turn off the machine and disconnect the battery connector.
- When removing the battery, unplug the battery connection, unplug the charger, and disconnect the battery terminals.
- To ensure safety, only use pads specified in this manual.
- When replacing parts, ask for ORIGINAL spare parts from an Authorized BETCO Dealer and/or Retailer.
- Have your BETCO service center check the machine once a year.
- When your BETCO machine is ready to be retired, the machine must be disposed of properly. It contains oils and electronic components. The machine was built using totally recyclable materials.
- Before recycling the machine, remove the battery.

INTRODUCTION

The GeneSys™ 20" Automatic Scrubber is designed for cleaning many types of hard flooring. As it advances, the scrub deck agitation combined with water/detergent solution loosens accumulated dirt from floors, and the squeegee and vacuum system collect the dirt and solution, leaving the floor clean. Use of this machine for any other purpose is not recommended.

For best performance and long machine life, the GeneSys™ 20" Automatic Scrubber must be properly maintained through regular cleaning and maintenance as outlined in this manual. Use of genuine Betco OEM parts is strongly recommended. For any questions about caring for the machine, or if issues should arise, please contact Betco's Technical Support Department or the nearest authorized Betco Equipment dealer.

MACHINE PREPARATION: UNPACKING

NOTE: Immediately upon receipt of the machine, check that all the materials indicated on delivery documents have been received and that the machine has not been damaged in transit. To receive any missing materials or to be compensated for shipping damage, immediately report any missing materials or damage to the carrier and to Betco's customer service department.

1. Remove the outer packing from the machine's shipping pallet. (Fig. 1)
2. Inspect the machine and contents for damage. Immediately report any damage found to Betco's Customer Service Department.
3. Remove interior packing materials and place contents of the box away from the pallet.
4. Cut all banding straps from machine.
5. Use a screwdriver to remove squeegee blocks and squeegee.
6. Raise the recovery tank and connect the red battery plug using the wrench provided.
7. Tuck the squeegee hose behind the water sight hose to prevent damage during unloading.
8. Fold down hinged ramp at back of machine. (Fig. 2)
9. Power the unit on with the key and raise the scrub head up to transport position.
10. Slowly reverse the machine backwards down the ramp. (Fig. 2)

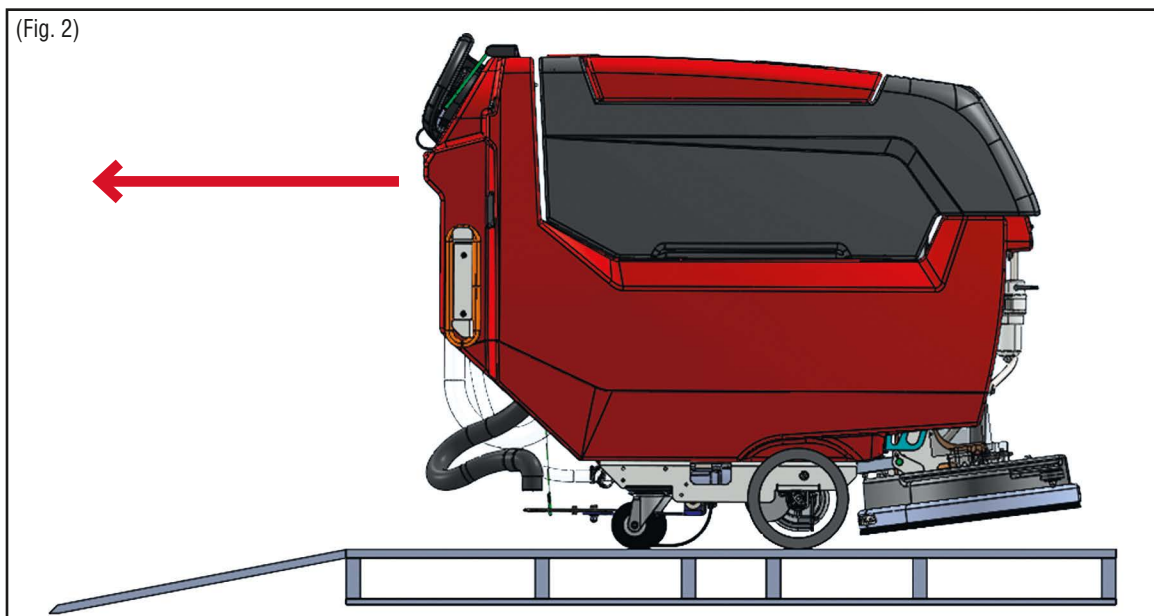
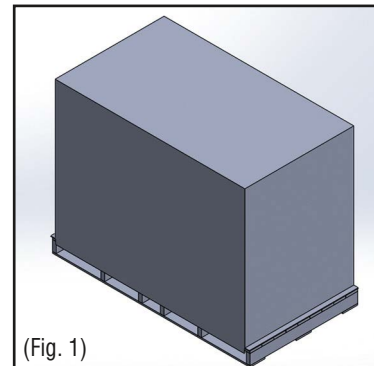

TRANSPORTING THE MACHINE: TIE DOWN PROCEDURE

When transporting, the GeneSys™ 20” Automatic Scrubber must be properly tied down to keep the machine protected and in good working condition. Using features of the machine’s design, below are suggestions to secure the machine efficiently and effectively during transport.



STEP 1

Before transporting up a trailer ramp, remove the squeegee assembly and place in an open, secure location on the trailer. If possible, wrap with a shipping blanket. Raise the scrub deck to the transport position.



STEP 2

Transport machine forward up the ramp into trailer and position it so that tie-downs can be used forward and rear of the machine. With pads installed, lower the scrub deck.



STEP 3

Open the recovery tank and route tie-down straps across the front and rear of the battery compartment as shown. Placing micro-fiber cloths or other material under the tie-down straps is recommended to protect the tanks from scratches.



STEP 4

Route front straps to tie-down locations forward of the machine. Route rear straps to tie down locations to the rear of the machine. Ratchet tie-downs until machine is secure.

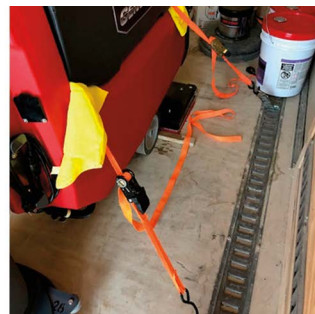

BATTERIES

The GeneSys 20" Automatic Scrubber is supplied with two 12-volt batteries and an onboard battery charger. The batteries, installed in the battery compartment beneath the recovery tank, may be either Wet Cell (aka Flooded), which require periodic maintenance, or maintenance-free Absorbed Glass Mat (AGM). To avoid possible damage or injury, the charger must be properly configured for the type of batteries being used.

BATTERY INSTALLATION/REPLACEMENT

⚠ WARNING: Wet Cell batteries release hydrogen gas!

- Keep sparks and open flame away.
- Do not smoke near the machine
- Charge batteries in a well-ventilated area with the battery compartment open.

⚠ WARNING: Do not wear jewelry when working near moving or electrical components.

⚠ CAUTION: Always wear appropriate protective equipment (gloves, goggles, etc.) when handling and charging batteries.

1. Lower the squeegee and brush deck.
2. Turn key off.
3. Open the battery compartment by using the side handle to lift the recovery tank.
4. Place the two 12-volt batteries into the battery compartment with positive and negative posts oriented as shown in Figure 4.
5. Wire the batteries with battery cables as shown in Figure 4.
6. Using the supplied 9/16" wrench, tighten the nuts to the battery terminals. To avoid damage to the batteries and sparking during operation, all nuts to the battery terminals must be torqued to 95-105 in-lb (11-12 N-m).

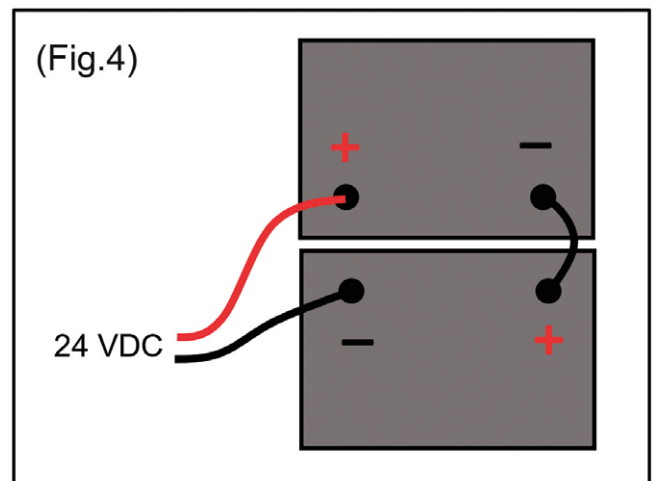

7. Connect the two red Anderson plugs located on the right side of the back control panel.

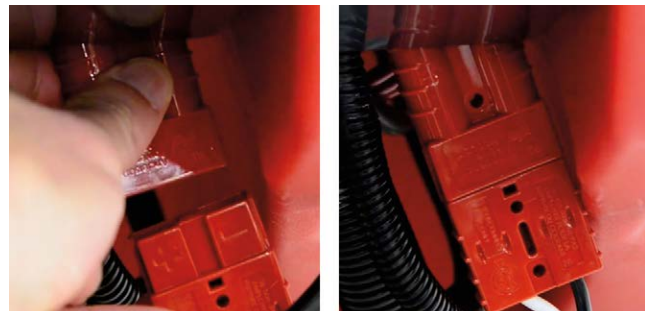

Note: The 12-volt batteries must be wired in series to achieve the required 24 VDC. Orienting the batteries as shown in Fig.4 allows for ease of wiring and proper connections between battery terminals.

⚠ WARNING: Perform one battery charging cycle before using the machine.

BATTERIES *continued*

BATTERY MAINTENANCE - WET CELL (FLOODED) BATTERIES ONLY

Wet cell (Flooded) batteries need water. Wet cell batteries contain lead plates submerged in an acidic electrolyte solution. The level of electrolyte decreases over time, potentially exposing the lead plates to air and causing poor performance and possible damage to the battery. The electrolyte level also varies with the amount of charge on the battery (higher with more charge, lower with less charge), but the level should always be enough to cover the lead plates regardless of charge.

The electrolyte levels of all wet cell batteries need to be checked periodically to ensure proper performance and long battery life. Depending on the local climate and use, Betco recommends that batteries should be checked at least once a week. If the machine sees heavy use, check batteries every 2 to 3 days.



CAUTION: The electrolyte solution is a highly corrosive mixture of sulfuric acid and water -- always wear appropriate protective equipment.

WARNING: Only add water to batteries. NEVER add acid to the batteries.

NOTE: It is strongly recommended to use distilled or deionized water only. Tap water or water with a high mineral content is not recommended and should be avoided.

STEPS TO PROPERLY “WATER” BATTERIES:

1. Before charging, open the fill cap to check the current electrolyte levels of each cell.
2. For any cell where the plates are not submerged and are exposed, add only enough water to cover the exposed plates and replace the fill cap. Do not completely fill partially or fully discharged batteries.



WARNING: Filling partially or fully discharged batteries to the recommended fill level will overflow the cell, causing the electrolyte solution to leak as the solution expands during charging.

3. Tightly replace all fill caps and fully charge the batteries.
4. After fully charging, open the fill cap to check the current electrolyte levels of each cell.
5. Add water to bring the electrolyte level of any cell to the recommended fill level as necessary. Fill levels for batteries generally are 1/8" to 1/4" below the vent tubes (See Fig.5). Check with the battery's manufacturer for the proper fill level for that brand and model.
6. Tightly replace all fill caps.



NOTE: Lead plates exposed to air can cause corrosion on the plates, decreasing performance and negatively impacting battery life. Proper electrolyte levels are only determined with fully charged batteries. Adding water to partially or fully discharged batteries should only be done to cover the lead plates and prevent corrosion.

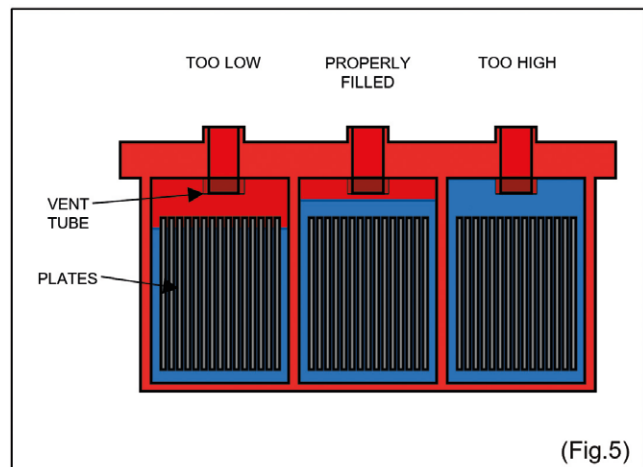

(Fig.5)

GENERAL BATTERY MAINTENANCE

Keeping the batteries clean from dust, dirt, and grime will help spot signs of trouble when they appear and avoid associated problems.

- Check that all vent caps are tightly in place.
- Clean the battery top with a cloth or brush and a solution of baking soda and water, rinse with clean water, and dry with a clean cloth. When cleaning, do not allow any cleaning solution or other foreign matter to get inside the battery.
- Clean battery terminals and the inside of cable clamps to a bright metallic shine using a post and clamp cleaner.
- Reconnect the clamps to the terminals and thinly coat them with an anti-corrosive spray or silicone gel.
- Keep the area around batteries clean and dry.

BATTERIES *continued*

MAINTAINING LEAD-ACID BATTERIES WITH FORTIFY™ WET BATTERY PROTECTION SYSTEM

The Fortify™ Wet Battery Protection System monitors the electrolyte levels of the batteries using a sensor inserted into the batteries and lights an indicator LED to notify the operator to water the batteries when levels are low.

NOTE: When low water levels are detected, scrubbing functions will be disabled until watering is completed.

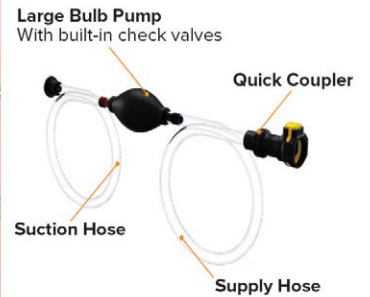

WARNING: Battery posts, terminals, and related accessories contain lead and lead compounds, chemicals known to the State of California to cause cancer and reproductive harm. During charging, strong inorganic acid mists containing sulfuric acid are released, a chemical known to the State of California to cause cancer.

STEPS TO “WATER” THE BATTERIES:

1. Use distilled water for filling the batteries. Place the distilled water jug below the top of the batteries to prevent siphoning. Insert the open end of the bulb pump into the jug of distilled water and prime the pump bulb by squeezing it until it is filled with water.
2. Attach the other end of the hose to the quick connect already on the batteries.
3. Squeeze the bulb to pump water into the battery cells. When the bulb becomes firm, all cells are full.



NOTE: Battery packs equipped with Fortify™ Wet Battery Protection may use more distilled water than expected to make the light turn off. Compress the bulb pump until it is no longer compresses. Not doing so may result in uneven filling and premature battery failure.



4. Immediately disconnect the couplers and replace the cap.

NOTE: Do not leave the pump and hose connected to the batteries after filling is complete.



ON-BOARD CHARGER

WARNING: Perform one battery charging cycle before using the machine.

The on-board charger, located on the bottom of the lower control panel, has LEDs to indicate the charging status and the type of battery to charge.

Before charging any batteries, use the “Select Battery Type” button on the charger to configure the charger for the type of battery that is being charged.

WET – Wet Cell (Flooded), requires regular “watering” (see BATTERY MAINTENANCE - WET CELL (FLOODED) BATTERIES ONLY)

AGM – Absorbed Glass Mat, maintenance-free

LITH – Lithium

NOTE: When replacing batteries with batteries of a different type, the charger must be configured to the new battery type. Not doing so can decrease performance and damage the battery.

While charging, the “Charge Status” LED change according to the charging stage of the charger.

Blinking Red – Bulk Stage

Solid Red – Absorption Stage

Solid Green – Charge Complete / Float Maintenance

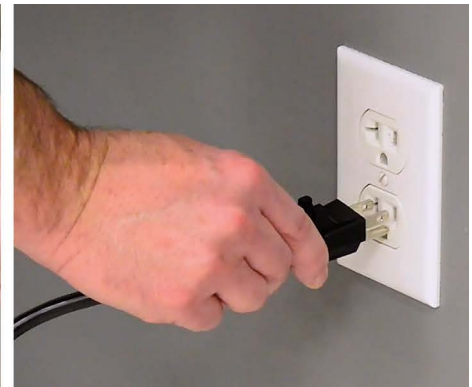

MACHINE PREPARATION / SETUP

SQUEEGEE INSTALLATION

1. Position the squeegee behind the machine and align the knob posts with the squeegee carrier slots.
2. Lift the squeegee and slide into the slots. (Fig. 1)
3. Tighten down the knobs to secure the squeegee. (Fig. 2)
4. Attach the vacuum hose to the squeegee. (Fig. 3)



(Fig. 1)



(Fig. 2)



(Fig. 3)

FILTER INSPECTION AND CLEANING

1. Close the shutoff valve for the solution tank.
2. Locate the filter housing under the frame between the transaxle and casters on the left side of the machine.
3. Unscrew and remove the filter bowl and screen to clean and remove debris.
4. For mineral deposits on the screen, descale the screen using a descaler or white vinegar.
5. Place the screen in the filter bowl and replace the bowl into the filter housing.

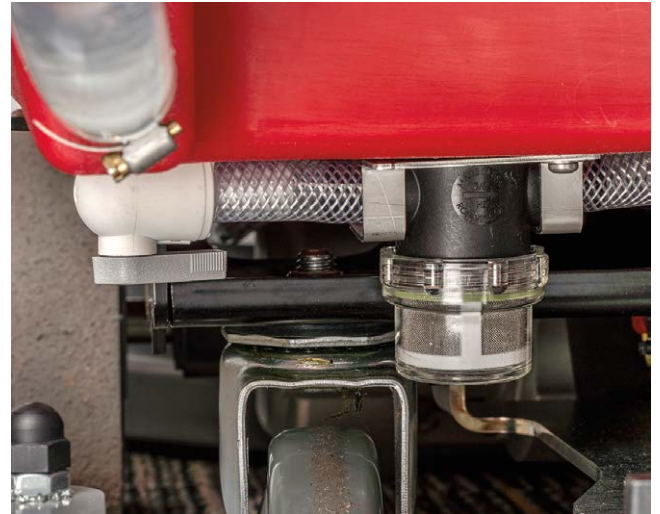

! *NOTE: If there is excessive debris found in the screen and bowl, drain and flush the solution tank thoroughly to remove any further debris.*



MACHINE OPERATIONAL CONTROLS

ON/OFF KEY SWITCH

The key switch controls power to the machine and is located on the lower control panel. Turn the key clockwise for on **(I)** and counterclockwise for off **(O)**.



CIRCUIT BREAKERS

Circuit breakers protect the GeneSys™ machine's motors from excessive electrical loads due to misapplications of the machine. Repeated tripping of a breaker will cause damage to the motor, potentially requiring the motor to be replaced.

! ***NOTE: If a breaker trips, allow the breaker to first cool, then press the white button on the breaker to reset it.***

CAUTION: Repeated tripping of a breaker may cause damage to any of the electrical components being protected by the breaker. A breaker repeatedly tripping may be an indication of a component failure or an electrical short – contact Betco® Technical Support immediately to address the issue.



BATTERY METER

The battery meter reports the accumulated machine hours and battery charge status. The number of battery charge lights indicates the amount of charge left in the batteries. When the battery has completely discharged leaving only a single red light, the machine will disable the brush drive motor to conserve the remaining charge, allowing pickup of any remaining solution on the floor and transport back to a charging location.



MACHINE OPERATIONAL CONTROLS

HEAD LIFT

The scrub deck control knob located on the console sets the scrub deck down pressure for cleaning, as well as raising the scrub deck for transport.

Select a scrub deck down pressure appropriate for the cleaning task to be done.

Low Pressure: Daily cleaning of normal soils

Medium Pressure: Heavy soils
Deep scrub
Orbital finish removal

High Pressure: Heavy soils
Orbital finish removal
Chemical stripping



SCRUB HEAD DOWN PRESSURE SETTING		
	GeneSys™ 20DT	GeneSys™ 200RB
Low	60	60
Medium	80	85
High	100	110

SOLUTION FLOW

The solution control knob adjusts the cleaning solution flow rate and is located on the lower control panel left of the key switch. Turn the solution control knob clockwise to increase and counterclockwise to decrease the flow rate.

NOTE: Cleaning solution is only dispensed when the scrub deck is down and the console bail is pushed forward or back.



DRIVE SYSTEM

MACHINE OPERATION

To drive the machine, use the console bail located just in front of the machine handle to control the forward and reverse movement, and the speed control knob to adjust the movement speed.

The speed control knob is located on the console handle and is used to control the movement speed of the machine. Rotating the speed control knob clockwise increases the movement speed, while rotating the knob counterclockwise decreases the speed. The speed can be adjusted while the machine is in motion or when it at rest.

⚠ NOTE: Before engaging the console bail to drive the machine, check that the speed control knob is not set to too high of a movement speed and adjust as necessary.

To move the machine forward, place hands around the console and bail and pull the bail back.

To reverse the machine, push the bail forward away from the console handle.

To stop the movement of the machine, release the bail and allow it to return to its neutral position.

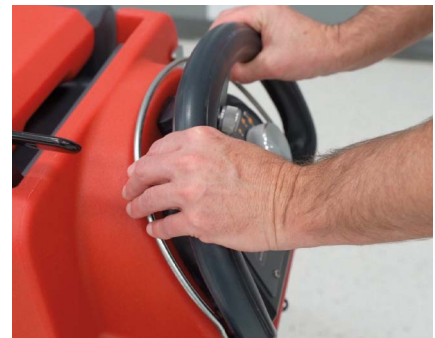

DISK MACHINE PAD DRIVER AND BRUSH

PAD DRIVER AND BRUSH REMOVAL

NOTE: *DO NOT use any machine without a pad or brush. Operating a machine without a pad or brush will damage the machine.*

1. Raise the scrub deck to the transport position.
2. Press the red "Auto Off" button, found in the center of the lower control panel. The pad drivers or brushes spin and release from the scrub deck.
3. Remove the pad drivers or brushes from under the scrub deck.



NEW PAD INSTALLATION

1. Release the centering ring by pressing down on the pad and squeezing the wire lock tabs of the centering ring inward until it releases.
2. Remove the old pad and any remnants from the bristles of the pad driver.
3. Place the new pad on the bristles of the pad driver, making sure to align center holes of the pad and pad driver.
4. Place the centering ring over the center of the pad and press down until the wire lock tabs click into place, securing the pad and centering ring to the pad driver.

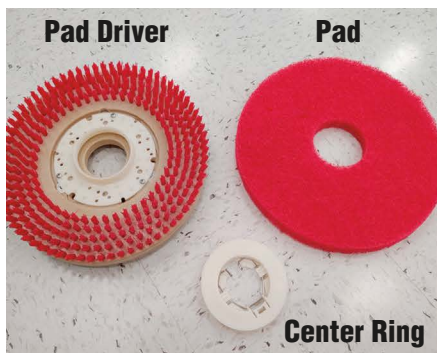

PAD DRIVER AND BRUSH INSTALLATION

1. Place the pad driver assemblies under the scrub deck and within the skirt of the scrub deck shroud.
2. Turn the key switch to the on position (I) and adjust the speed control knob to the slowest speed by turning the knob fully counterclockwise.
3. Lower the scrub deck to MEDIUM down pressure.
4. To help align the attachment lugs of the pad driver to the scrub deck motors, slightly pull or push the machine, allowing the motor hubs to drop into the center holes of the pad driver assemblies.
5. Pull back on the console bail to activate the scrub deck motors and engaging the attachment lugs with the motor hubs.
6. Raise the scrub deck to the transport position to check that the pad driver assemblies correctly attached to the scrub deck. If the pad driver did not attach, return to step 3 and repeat as necessary.

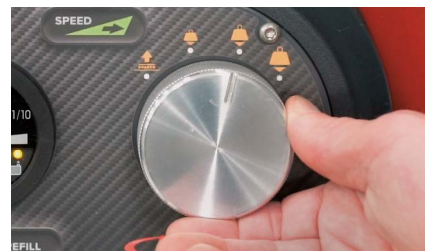

ORBITAL MACHINE PAD

STANDARD CLEANING OPERATIONS

⚠ NOTE: DO NOT use any machine without a pad. Operating a machine without a pad will damage the machine.

1. Attach an orbital pad to the scrub head by overlapping the front by ½” and aligning the sides. The overlap of the pad to the scrub head helps the pad more evenly absorb and distribute the cleaning solution.
2. Press the pad into position once the pad is aligned.
3. Lower the scrub deck onto the floor and check that the pad is properly aligned.

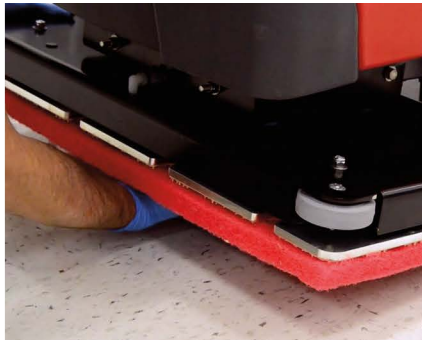

ORBITAL FINISH REMOVAL

Finish removal uses a two-pad setup. A red or white pad acts as a “backer pad” that helps compensate for flaws and variations in the floor. A maroon pad is for surface preparation.

1. Attach the red pad to the orbital pad driver plate as shown above.
2. Wet the maroon pad prior to installation to minimize excessive friction upon initial start up.
3. Place the maroon pad on the floor and position it so that when the scrub deck is lowered the red and maroon pads are aligned and stacked.
4. Fill the solution tank with clean water.
5. Install the pad assembly as described above.
6. Depending on condition or hardness of the finish being removed, the scrub deck down pressure should be set to medium or high pressure
7. The solution flow rate should be set to a low flow rate (approximately 25% of full flow rate) to maximize finish removal, to rinse, clean the floor and pad.
8. Forward speed should be set to 25% to 50% of normal speed to ensure maximum finish removal (approximately 50-100 feet per minute).

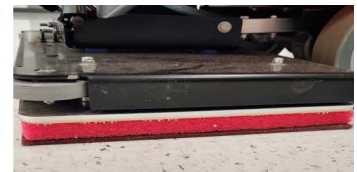

RECOVERY SYSTEM

DRAINING THE RECOVERY TANK

1. Find an approved drain location to empty the recovery tank.
2. Lift the drain hose off of the hose hook, remove the cap (keeping it above the tank's water level), fold over the collar and lower into the drain location.
3. Let the dirty water drain into the drain by slowly releasing the collar.
4. While draining, lift the recovery tank lid to the wide-open position.



CLEANING THE RECOVERY TANK WHEN DRAINING

1. Rinse out the recovery tank often to prevent buildup of dirt, debris, and any contaminants.
2. Use a hose to wash debris and sediment from the bottom of the tank.

⚠ NOTE: Regularly use cleaner and sanitizer with a cloth or sponge to prevent mold and mildew inside the recovery tank.

VACUUM BALL CAGE

1. Remove clamp (if present) and vacuum ball cage filter.
2. Rinse the filter thoroughly.
3. Replace vacuum ball cage filter and clamp (if present).

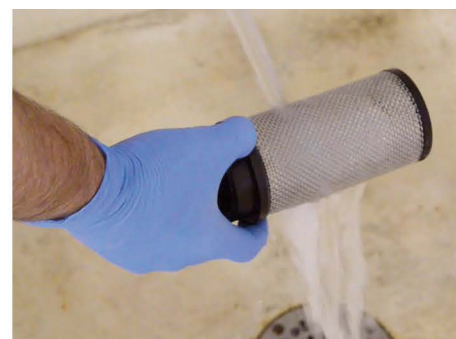
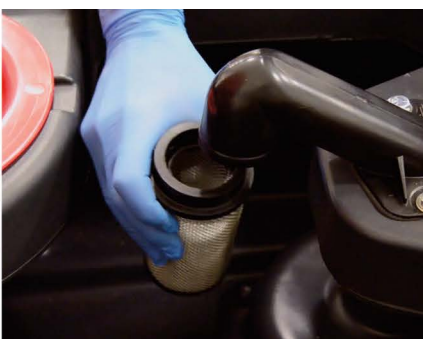

RECOVERY SYSTEM *continued*

FORTIFY™ FOAM CONTROL

Proactively control foam in the recovery tank and protect the vacuum fan with the Fortify™ foam control puck underneath the debris tray inside the recovery tank.

FORTIFY™ FOAM CONTROL PUCK REPLACEMENT

1. Open the recovery tank lid. Remove the debris tray and flip it over.
2. Turn the puck cage counterclockwise to release it from the debris tray. Replace puck as needed. Reattach puck cage to the debris basket.
3. Return debris basket to recovery tank.



⚠️ WARNING: DO NOT use chlorine. Harmful fumes can be created from mixed cleaners and chlorine.



RECOVERY LID

Leave the recovery lid open after cleaning and while in storage. This allows the recovery tank to dry quickly and reduces the chance of mold and mildew growth.



SQUEEGEE ASSEMBLY

The GeneSys™ 20" Automatic Scrubber comes standard with Linatex® squeegee blades, providing tear-resistance and wet-abrasion resistance for optimal water pick-up on most floor surfaces.

The Linatex® blades use the patented Airoflex® design which features valves along the squeegee blade edge. The Airoflex® valves flex open when on smooth floors and close on porous or grouted tile floors to increase vacuum performance by up to 40%.



⚠ CAUTION: DO NOT ADJUST SQUEEGEE CASTER HEIGHT.
The caster height has been set at the factory for optimal squeegee performance.

SQUEEGEE BLADES CLEANING

1. Remove the squeegee assembly from the machine by loosening the two knobs.
2. Thoroughly clean and rinse the underside of the squeegee frame, blades and neck.
3. Wipe down and dry the squeegee to remove any water and loose debris.



SQUEEGEE BLADES INSPECTION

1. Inspect the front and rear squeegee blades. The forward edges should be sharp and defined.
2. Worn blades should be flipped or replaced if worn halfway through the thickness.

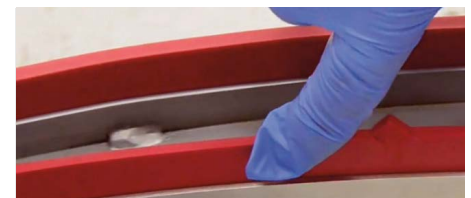

SQUEEGEE BLADE REMOVAL AND INSTALLTION

1. Release the latch and slide the band clamp off the hook on the other side.
2. Blades can be flipped length wise or top to bottom to use all four edges over the lifetime of the blade.
3. Place the blade over the assembly ensuring the holes align and replace the band clamp - make sure snug and tight when clamped.



SQUEEGEE ASSEMBLY *continued*

DRIP TRAP INSPECTION

1. Inspect the drip trap on the topside of the squeegee by removing the two thumb screws.
2. Rinse off the drip trap and remove any debris.
3. Wipe and clean the squeegee frame before re-installing the drip trap.



SQUEEGEE OPERATION

1. To lower the squeegee, move the squeegee lever to the right. The vacuum motor will come on.
2. To raise the squeegee, move the squeegee lever to the left. The vacuum motor will turn off after 7 seconds.

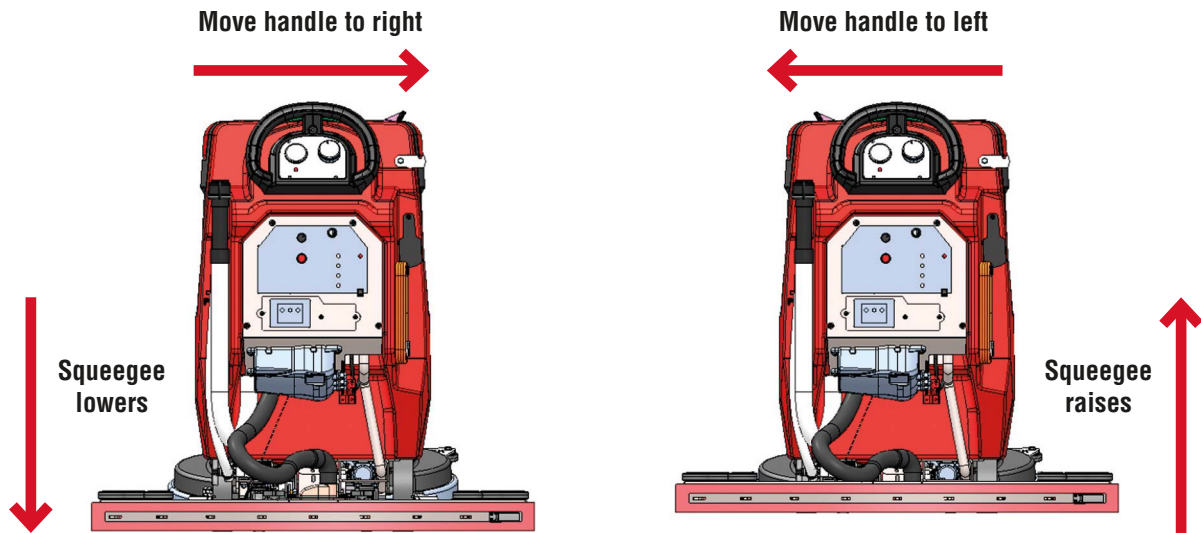

SOLICHEM™ TECHNOLOGY SYSTEM

Betco's SoliChem™ Technology is an on-board chemical proportioning system that eliminates the need to pour chemical into the solution tank. Plain water from the solution tank flows over a SoliChem™ solid, dissolving the solid, and the proportioned cleaning solution is delivered directly to the scrub deck. As the solid dissolves, the SoliChem™ system monitors the amount of cleaning agent delivered to the scrub deck and alerts the operator when the SoliChem™ solid has been depleted and needs to be replaced.

⚠️ WARNING: Never use acidic chemicals which could damage the machine. Do not use water exceeding 120° F (48.9° C).

SOLICHEM™ SETUP AND OPERATION

1. Add water to the solution tank through the front or rear fill locations, watching the sight tube on the back of the machine to determine when the solution tank is full.



2. Lift the recovery tank and remove the SoliChem™ canister cap.
3. Lift out the canister cage and remove any remaining solids (if present).
4. Place a new SoliChem™ solid into the canister cage and insert cage into canister.
5. Replace the SoliChem™ canister cap.



6. During scrubbing operations, the “SoliChem™ Refill” LED indicator on the console will light to indicate that the SoliChem™ solid has sufficiently dissolved and may need to be replaced. Follow Steps 3 thru 6 to replace the SoliChem™ solid.

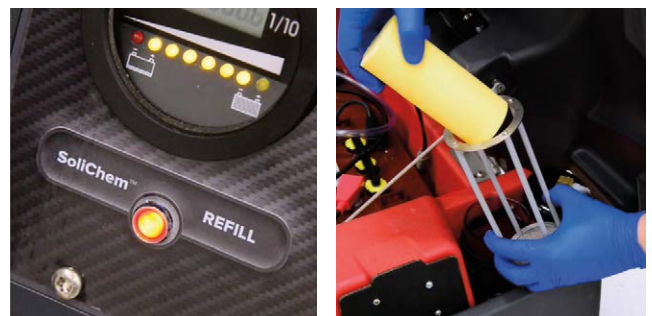

CONVENTIONAL OPERATION WITHOUT SOLICHEM™

1. Lift the recovery tank and remove the SoliChem™ canister cap.
2. Lift out the canister cage and remove any remaining solids (if present).
3. Insert the empty cage into canister and replace the SoliChem™ canister cap.
4. Turn off SoliChem™ level monitoring using the “SoliChem™ On/Off” switch located on the lower controls panel.
5. Add in properly diluted chemical (as desired) into the front fill port.



FORTIFY™ ARMOR™ TELEMETRY

The optional ARMOR™ Telemetry unit can monitor and report various metrics of machine performance, including run time activity, charging history, and impact notifications. The information collected is sent via cellular network to Armordata.com, where the web-based dashboard interface allows easy viewing of the equipment's productivity can be tracked.

DEVICE REGISTRATION

1. Locate and write down the serial number of the machine on the bottom of the recovery tank in the battery compartment.
2. Determine the facility that the machine will operate in, the person that will be monitoring the machine, and the main service contact.
3. Go to www.armordata.com and click the "Register an ARMOR Device" link under ARMOR Support.
4. Fill out the form and click "Save info and register device".

NOTE: The machine data will appear in the Armordata.com dashboard on the next business day. A 12-month free subscription to Armordata.com is included with the purchase of the Fortify™ Armor™ option, and begins once the unit has been registered.

ARMOR™ TELEMETRY BUTTONS

Maintenance Performed	Press and hold to log that the machine has been maintained
New Batteries Installed	Press and hold to log that new batteries have been installed
Silence Alarm	Press to silence the alarm for 24 hours



DATA COLLECTION

The ARMOR™ Telemetry device automatically uploads collected data once a day and after every charge/discharge event. If the device cannot connect to a cellular network, it will store the data and send once a connection is restored. The data recorded by the ARMOR device can be viewed at ARMOR's website, <http://armordata.com>.

RECORDING MAINTENANCE EVENTS

The buttons on the ARMOR™ Telemetry device allow the operator to record when various maintenance events are performed on the machine. To record when general maintenance event has been completed, press and hold the "Maintenance Performed" button, or when batteries have been replaced, press and hold the "New Batteries Installed" button.

If the ARMOR™ Telemetry device alarm is activated, operator can silence the alarm by pressing the "Silence Alarm" button. The alert notification on Armordata.com will remain in effect until resolved.

When the operator has an issue with the machine and needs assistance, a notification can be sent to Armordata.com, which will notify anyone who has been registered to receive notifications, by pressing and holding the "Maintenance Performed" button and the "Silence Alarm" button at the same time.

FORTIFY™ PROGRAMMABLE TIMER LOCKOUT

The optional timer lockout can be programmed to limit operation of the machine by time of day and days of the week, preventing unauthorized use while not interfering with productivity. A red status light on the timer lockout is active when timer lockout has enabled machine operation. The timer is located on the back panel of the machine and is protected from tampering by a metal cover.

BUTTONS

WEEK	Changes the day of the week.
HOUR	Increments the hour.
MIN	Increments the minute.
RECALL	Recalls or clears the last settings of a program.
CLOCK	Allows adjustment of the clock when held down
PROG	Indexes through each programs on/off settings.
MANUAL	Cycles through machine modes.
R	Resets the timer to the factory settings.



TIME OF DAY CLOCK ADJUSTMENT

1. If necessary, press the **“CLOCK”** button to display the current time of day.
2. To adjust the current day of the week, press and hold the **“CLOCK”** button and press the **“WEEK”** button to select the current day of the week.
3. To adjust the current time of day, press and hold the **“CLOCK”** button and press the **“HOUR”** or **“MIN”** button to select the hour and minute of the current time of day.
4. Release the **“CLOCK”** button when correct day of week and time have been set.



NOTE: Pressing and holding the **“CLOCK”** button for 3 seconds toggles the clock display between 12-hour and 24-hour time.

TIMER LOCKOUT OPERATION

The timer lockout enables or disables machine operation based on the timer lockout mode selected. The timer lockout mode is selected by pressing the **“MANUAL”** button on the timer to cycle through the three modes of operation:

“ON”	Machine operation is enabled regardless of programming.
“OFF”	Machine operation is disabled regardless of programming.
“AUTO”	Machine operation is enabled or disabled based on programming.

TIMER LOCKOUT PROGRAMMING

When the timer lockout mode is set to **“AUTO”**, operation of the machine is enabled or disabled according to the programmed time schedules stored in the timer. Up to 16 programs can be created, each scheduling the day(s) of the week and times of day interval for the machine operation to be enabled and disabled (**“1on”**, **“1off”**, ... **“16on”**, **“16off”**).

1. Press the **“PROG”** button to enter programming mode.
2. Press the **“PROG”** button to select the program number to configure. Each program requires setting a time to enable machine operation (e.g. **“4on”**) and a time to disable machine operation (e.g. **“4off”**). Pressing the **“PROG”** button will cycle thru all 16 programs and their respective **“on”** and **“off”** time settings.
3. With the desired program and **“on”** or **“off”** number selected, press the **“WEEK”** button until the desired day(s) are displayed at the top of the screen to enable or disable machine operation.
4. Press the **“HOUR”** and **“MIN”** buttons until the desired time is displayed to enable or disable machine operation.
5. While in programming mode, pressing **“PROG”** will continue to cycle through program numbers, allowing the configuring of any of the 16 available programs.
6. Press the **“CLOCK”** button to leave programming mode.
7. To enable the timer lockout to use the programmed time schedules for machine operation, press the **“MANUAL”** button until **“AUTO”** is shown on the right to enable the programs.



NOTE: While in the programming mode **“RECALL”** will disable the displayed program or load the previous setting used for that program.

NOTE: When setting a program to be used overnight, ensure that the **“on”** and **“off”** settings for consecutive days (e.g. Friday 10PM **“on”** and Saturday 8AM **“off”**).

FRAME DIAGRAM

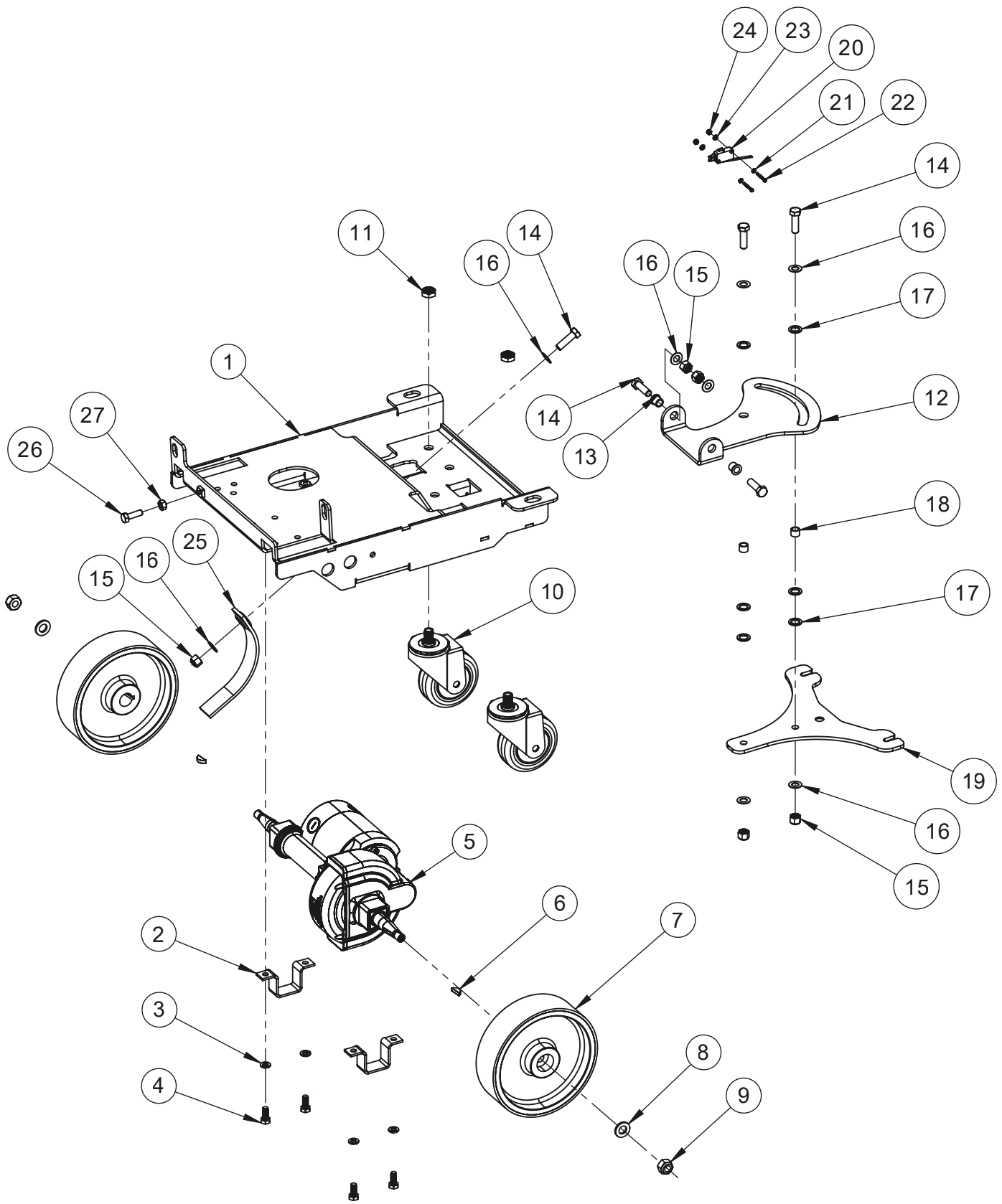

FRAME PARTS LISTING

Item#	Part #	Description	Qty.	Item#	Part #	Description	Qty.
1	E28878-00	FRAME, WELDMENT, GENESYS 20	1	15	E11146-00	NUT, HEX, 3/8-16, NYLOC, ZP	5
2	E29400-00	BRACKET, TRANSAXLE MTG	2	16	E29438-00	WASHER, FLAT, 0.406 ID x 0.750 OD, 0.040 THK	8
3	E81067-00	WASHER, LOCK, 0.322 ID x 0.583 OD, SPLIT, ZP	4	17	E28937-00	WASHER, FLAT, 0.505 ID x 0.750 OD, 0.067 THK, NYLON	6
4	E81089-00	BOLT, HEX HD, 5/16-18 x 0.750 LG, ZP	4	18	E28936-00	BEARING, SLEEVE, 0.375 ID x 0.501 OD x 0.375 LG	2
5	E28876-00	TRANSAXLE, 16.8 LG	1	19	E28880-00	PLATE, SQUEEGEE SWING	1
6	E29439-00	KEY, WOODRUFF, 19mm DIA x 5mm	2	20	E28952-00	SWITCH, SNAP ACTION, SPDT	1
7	E28882-00	WHEEL, 7in TRANSAXLE	2	21	E28821-00	WASHER, LOCK, 0.115 ID x 0.260 OD, EXT TOOTH, ZP	2
8	E83702-00	WASHER, FLAT, 13mm ID x 24mm OD, 2.7mm THK	2	22	E28769-00	SCREW, SOC HD HEX, #4-40 x 0.875 LG, SS	2
9	E86489-00	NUT, HEX, M12-1.75, NYLOC	2	23	E29368-00	WASHER, FLAT, 0.125 ID x 0.312 OD, 0.030 THK	2
10	E29021-00	CASTER, 3.500 WHEEL DIA, 1/2-13 x 0.750 STEM	2	24	E28770-00	NUT, HEX, #4-40, NYLOC	2
11	E81088-00	NUT, HEX, 1/2-13, JAM, NYLOC, ZP	2	25	E29459-00	STATIC STRAP	1
12	E28879-00	BRACKET, SQUEEGEE LIFT	1	26	E81072-00	BOLT, HEX HD, 5/16-18 x 1.000 LG	1
13	E28591-00	BEARING, SLEEVE, 0.376 ID x 0.501 OD, 0.500 LG, FLANGED	2	27	E12524-00	NUT, HEX, 5/16-18, SS	1
14	E29436-00	BOLT, HEX HD, 3/8-16 x 1.250 LG, SS	5				

HEAD LIFT DIAGRAM

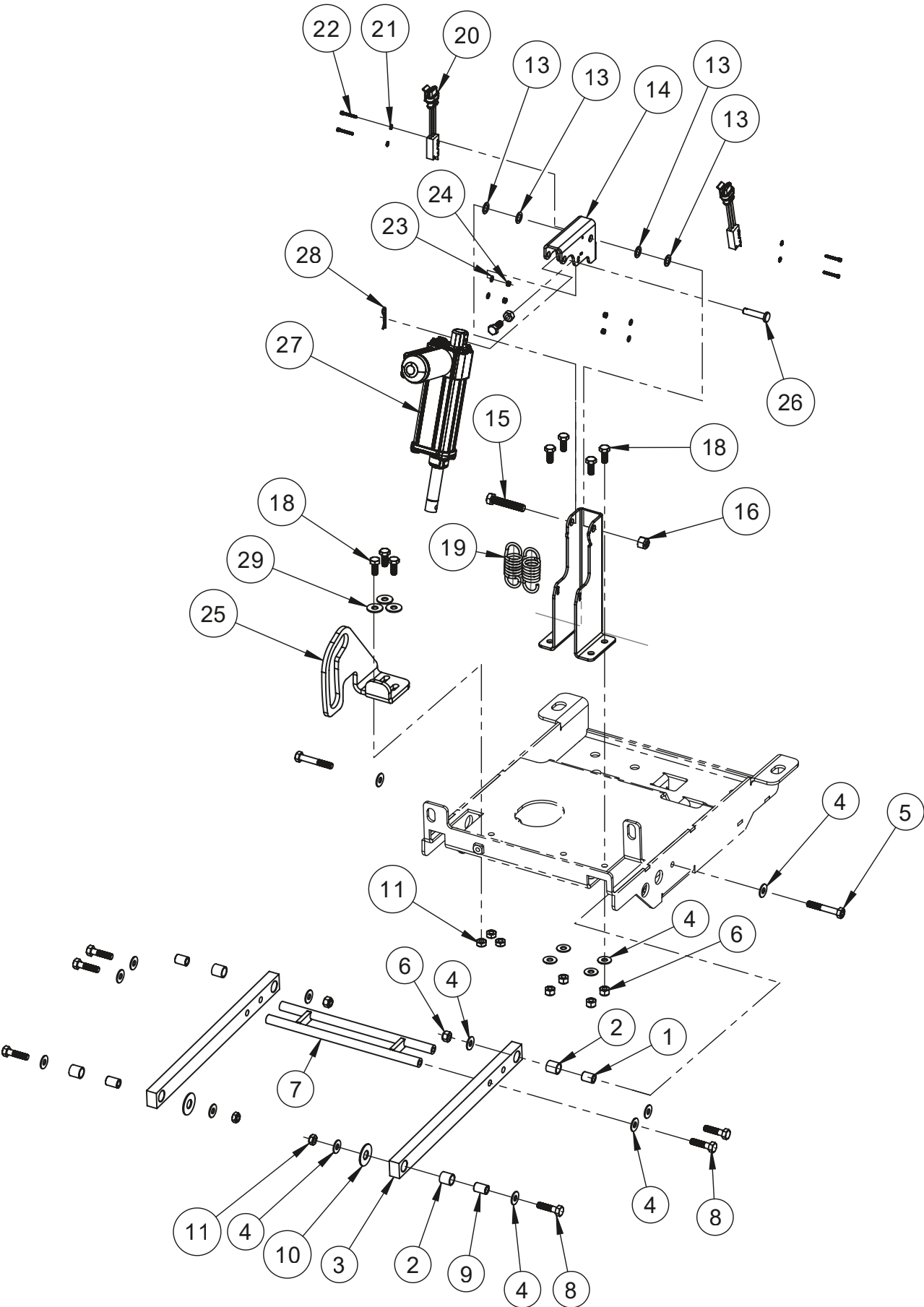

HEAD LIFT PARTS LISTING

Item#	Part #	Description	Qty.	Item#	Part #	Description	Qty.
1	E28684-00	BUSHING, SLEEVE, 0.323 ID x 0.497 OD, 0.655 LG	2	16	E11146-00	NUT, HEX, 3/8-16, NYLOC, ZP	1
2	E28685-00	BUSHING, SLEEVE, 0.501 ID x 0.627 OD, 0.625 LG	4	17	E12524-00	NUT, HEX, 5/16-18, SS	1
3	E28863-00	ARM, HEAD LIFT	2	18	E81089-00	BOLT, HEX HD, 5/16-18 x 0.750 LG, ZP	8
4	E28622-00	WASHER, FLAT, 0.344 ID x 0.750 OD, 0.050 THK, SS	16	19	E28700-00	Head Lift Spring	2
5	E28982-00	BOLT, HEX HD, 5/16-18 x 2.000 LG, YC, GRADE 8	2	20	E20704-00	ASSEMBLY, HEAD LIFT SWITCH, GENESYS	2
6	E28624-00	NUT, HEX, 5/16-18, NYLOC, SS	6	21	E28821-00	WASHER, LOCK, 0.115 ID x 0.260 OD, EXT TOOTH, ZP	4
7	E28864-00	BRACE, LIFT ARM, WELDMENT	1	22	E28769-00	SCREW, SOC HD HEX, #4-40 x 0.875 LG, SS	4
8	E10112-00	BOLT, HEX HD, 5/16-18 x 1.250 LG, ZP	6	23	E29368-00	WASHER, FLAT, 0.125 ID x 0.312 OD, 0.030 THK	4
9	E28693-00	BUSHING, SLEEVE, 0.323 ID x 0.497 OD, 0.720 LG	2	24	E28770-00	NUT, HEX, #4-40, NYLOC	4
10	E83145-00	WASHER, FLAT, 0.520 ID x 1.252 OD, 0.061 THK, NYLON	2	25	E28865-00	PLATE, HEAD LIFT GUIDE	1
11	E28623-00	NUT, HEX, 5/16-18, THIN, NYLOC, SS	5	26	E28985-00	PIN, CLEVIS, M8 x 30mm, ZP	1
12	E28866-00	ACTUATOR TOWER	1	27	E28877-00	ACTUATOR, 100mm TRAVEL	1
13	E28830-00	WASHER, FLAT, 0.390 ID x 0.625 OD, 0.041 THK, NYLON	4	28	E28847-00	COTTER PIN, 0.25 EYE, 0.125 WIRE, ZP	1
14	E28867-00	ACTUATOR PIVOT	1	29	E81062-00	WASHER, FLAT, 0.344 ID x 0.875 OD, 0.063 THK, ZP	3
15	E87644-00	BOLT, HEX HD, 3/8-16 x 2.000 LG, ZP	1				

DISK HEAD DIAGRAM

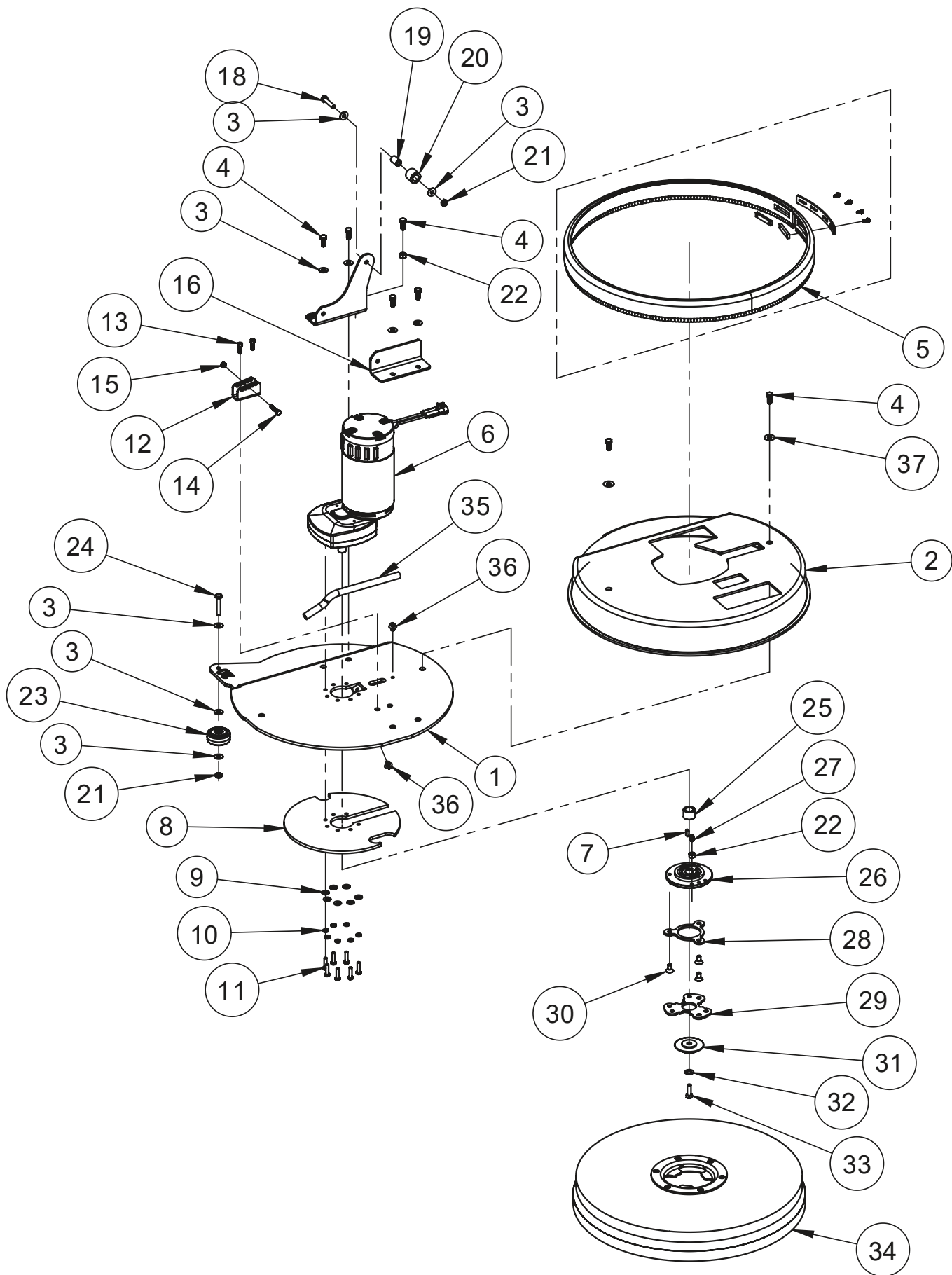

DISK HEAD PARTS LISTING

Item#	Part #	Description	Qty.	Item#	Part #	Description	Qty.
1	E28855-00	FRAME, DISK HEAD, 20in, WELDMENT	1	20	E29012-00	ROLLER, 0.575 ID x 1.000 OD, 0.850 LG	1
2	E28881-00	SHROUD, DISK HEAD w/ CUTOUTS, 20in	1	21	E28623-00	NUT, HEX, 5/16-18, THIN, NYLOC, SS	2
3	E28622-00	WASHER, FLAT, 0.344 ID x 0.750 OD, 0.050 THK, SS	9	22	E12524-00	NUT, HEX, 5/16-18, SS	2
4	E81089-00	BOLT, HEX HD, 5/16-18 x 0.750 LG, ZP	7	23	E28598-00	WHEEL, COLSON ROLLER, 2in	1
5	E28857-00	ASSEMBLY, SKIRT, DISK HEAD, 20in	1	24	E29513-00	BOLT, HEX HD, 5/16-18 x 1.750 LG	1
6	E29017-00	MOTOR, DISK HEAD, 230RPM	1	25	E29042-00	SPACER, 0.336 ID x 0.500 OD, 0.760 LG, ZINC	1
7	E28911-00	KEY, MACHINE, 5mm x 5mm, ROUNDED	1	26	E29037-00	HUB, DISK COUPLER	1
8	E28856-00	WEIGHT, DISK HEAD, 20in	1	27	E28910-00	SPRING PLUNGER, SLOTTED, 5/16-18 x 0.578 LG, SS	1
9	E28617-00	WASHER, FLAT, 0.281 ID x 0.625 OD, 0.050 THK, SS	7	28	E29039-00	PLATE, ENGAGEMENT, DISK COUPLER	1
10	E29385-00	WASHER, LOCK, 6.5mm x 11.8mm, SPLIT, ZP	7	29	E29040-00	PLATE, RETAINER, DISK COUPLER	1
11	E29386-00	BOLT, HEX HD, M6-1 x 24mm LG, ZP	7	30	E28639-00	SCREW, FLAT HD HEX, 5/16-18 x 0.625 LG	3
12	E28861-00	BRACKET, ACTUATOR MOUNT	1	31	E29041-00	GUIDE, ALIGNMENT, DISK COUPLER	1
13	E28986-00	SCREW, SOC HD HEX, 1/4-20 x 0.750 LG, ZP	2	32	E29438-00	WASHER, FLAT, 0.406 ID x 0.750 OD, 0.040 THK	1
14	E84204-00	BOLT, HEX HD, M6-1 x 30mm LG, SS	1	33	E29426-00	BOLT, HEX HD, M8-1.25 x 25mm LG	1
15	E83550-00	NUT, HEX, M6-1, NYLOC, ZINC	1	34	E28858-00	ASSEMBLY, PAD DRIVER, GENESYS 20	1
16	E28860-00	BRACKET, LH DECK MOUNT, 20in	1	35	EP50231-00	TUBE, 0.375 ID, CLEAR PVC, 18.00 LG	1
17	E28859-00	BRACKET, RH DECK MOUNT, 20IN, WELDMENT	1	36	E28621-00	WIRE TIE PUSH MOUNT	2
18	E28694-00	BOLT, HEX HD, 5/16-18 x 1.500 LG, PT	1	37	E81062-00	WASHER, FLAT, 0.344 ID x 0.875 OD, 0.063 THK, ZP	2
19	E29019-00	BUSHING, SLEEVE, 0.323 ID x 0.563 OD, 0.90 LG	1				

ORBITAL MOTOR AND BEARING HUB DIAGRAM

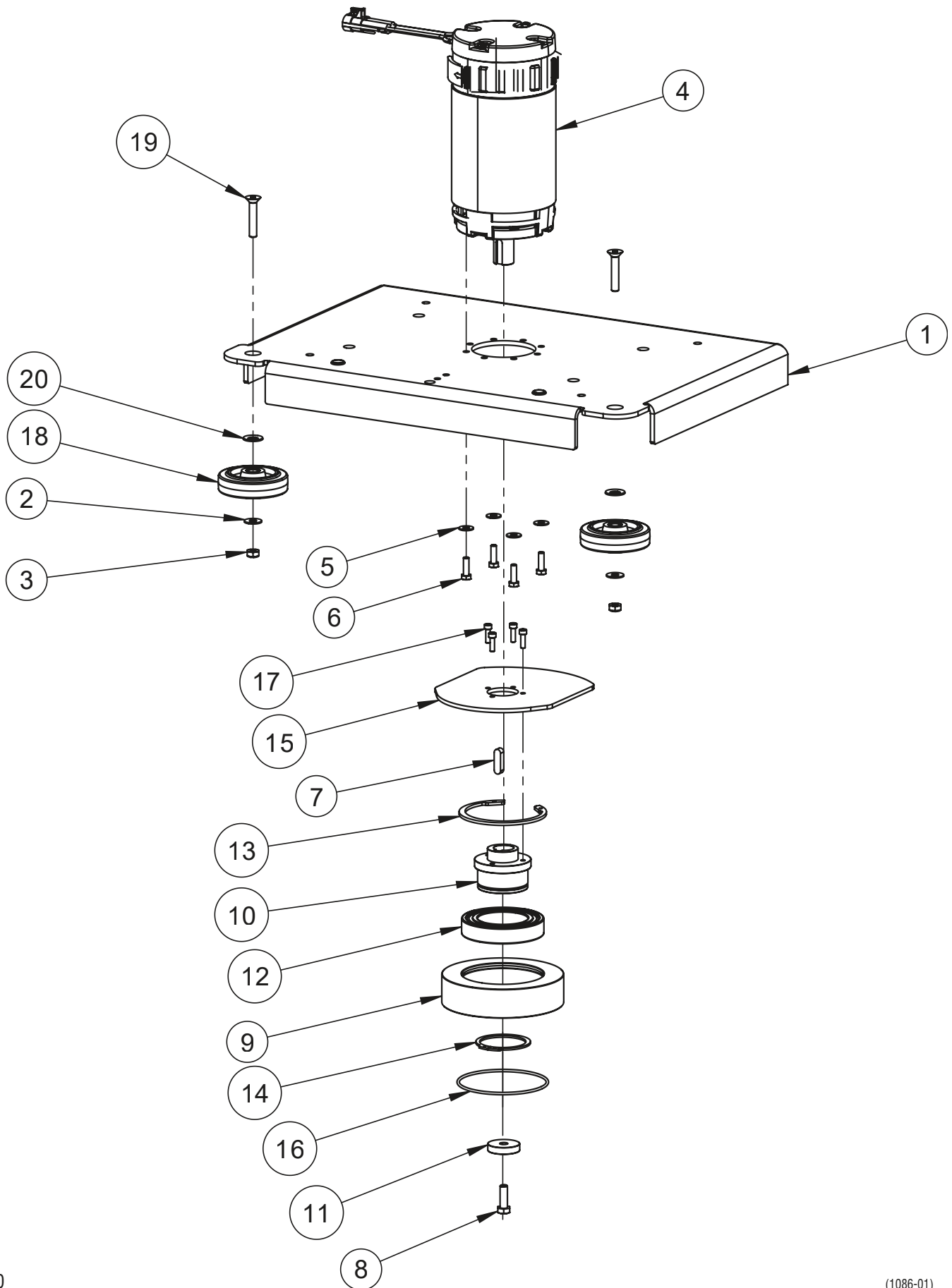

ORBITAL MOTOR AND BEARING HUB PARTS LISTING

Item#	Part #	Description	Qty.	Item#	Part #	Description	Qty.
1	E28896-00	FRAME, ORBITAL HEAD, 20in, WELDMENT	1	11	E28631-00	HUB WASHER	1
2	E28622-00	WASHER, FLAT, 0.344 ID x 0.750 OD, 0.050 THK, SS	2	12	E28524-00	BALL BEARING, SKF DEEP GROOVE, 6011 2RS1/C3GJN	1
3	E28623-00	NUT, HEX, 5/16-18, THIN, NYLOC, SS	2	13	E28632-00	RETAINING RING, INT., 90mm BORE x 3.15mm GROOVE	1
4	E28521-00	MOTOR, 24VDC, 2200 RPM, 0.75 HP	1	14	E28529-00	RETAINING RING, EXT. 55mm SHAFT x 2.15mm GROOVE	1
5	E28617-00	WASHER, FLAT, 0.281 ID x 0.625 OD, 0.050 THK, SS	4	15	E28009-00	COUNTERWEIGHT, ORBITAL, 20"	1
6	E83914-00	BOLT, HEX HD, M6-1 x 15mm LG	4	16	E28527-00	O-RING, 3.737 ID x 0.103 DIA, BUNA-N	1
7	E28635-00	MACHINE KEY, 8mm x 7mm x 28mm, ROUNDED	1	17	E29431-00	SCREW, SOC HD HEX, #10-24 x 0.625 LG	4
8	E29426-00	BOLT, HEX HD, M8-1.25 x 25mm LG	1	18	E28509-00	WHEEL, COLSON ROLLER, 3in	2
9	E28525-00	BEARING HUB, ORBITAL	1	19	E28634-00	SCREW, FLAT HD HEX, 5/16-18 x 1.750 LG	2
10	E29025-00	BEARING HUB, ECCENTRIC (0.85" OFFSET)	1	20	E28640-00	WASHER, LOCK, 0.451 ID x 0.848 OD, SPRING, PLASTIC	2

ORBITAL HEAD LIFT BRACKETS DIAGRAM

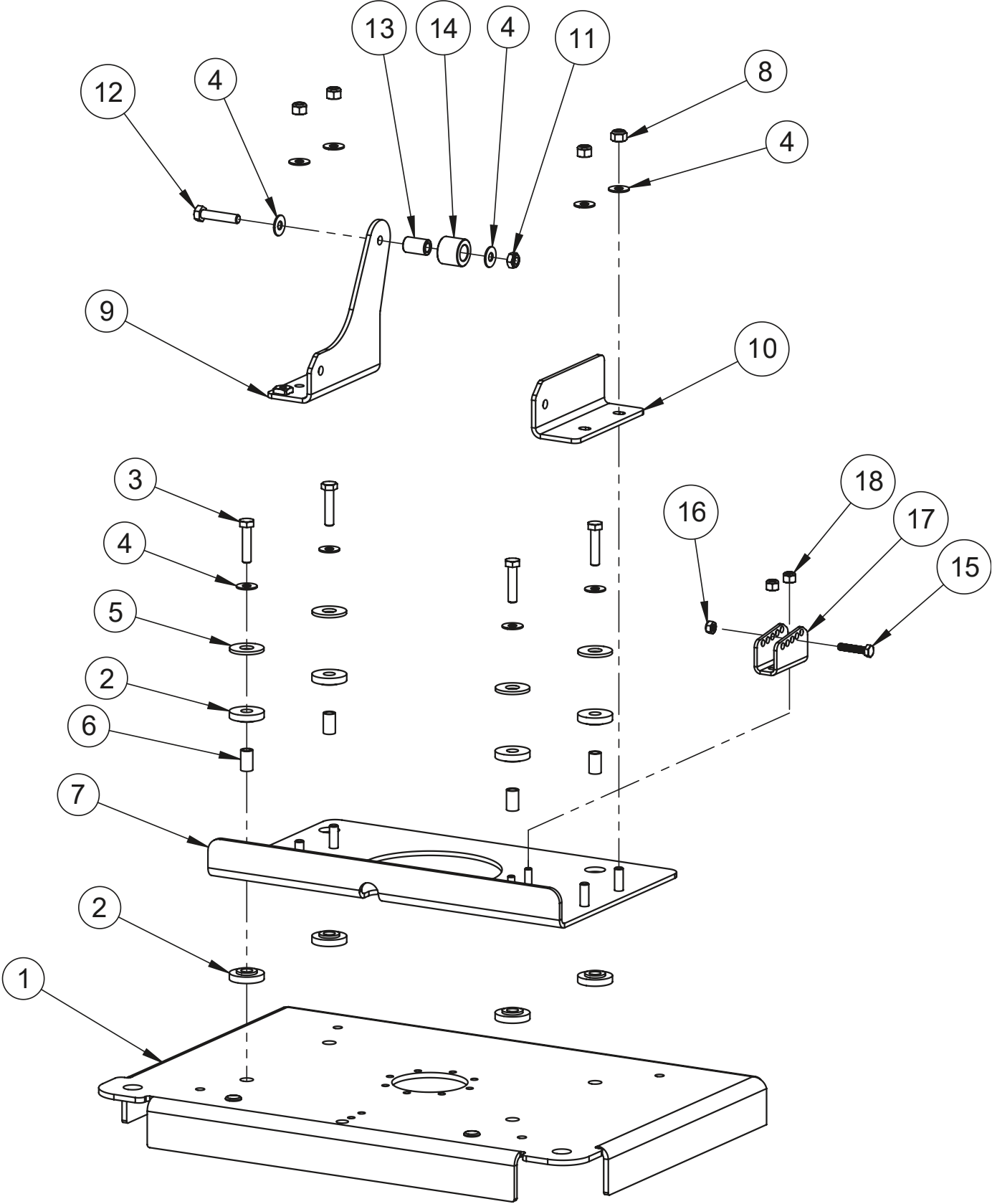

ORBITAL HEAD LIFT BRACKETS PARTS LISTING

Item#	Part #	Description	Qty.
1	E28896-00	FRAME, ORBITAL HEAD, 20in, WELDMENT	REF
2	E28531-00	ISOLATOR BUSHING, 0.313 ID x 1.250 OD, PVC BLUE	8
3	E29553-00	BOLT, HEX HD, 5/16-18 x 1.375 LG, SS	4
4	E28622-00	WASHER, FLAT, 0.344 ID x 0.750 OD, 0.050 THK, SS	10
5	E28764-00	WASHER, FLAT, 0.500 ID x 1.250 OD, 0.104 THK	4
6	E28656-00	BUSHING, 0.313 ID x 0.439 OD, 0.750 HT, BRONZE	4
7	E28981-00	BRACKET, ORBITAL HEAD LIFT, WELDMENT	1
8	E28624-00	NUT, HEX, 5/16-18, NYLOC, SS	4
9	E28859-00	BRACKET, RH DECK MOUNT, 20IN, WELDMENT	1

Item#	Part #	Description	Qty.
10	E28860-00	BRACKET, LH DECK MOUNT, 20in	1
11	E28623-00	NUT, HEX, 5/16-18, THIN, NYLOC, SS	1
12	E28694-00	BOLT, HEX HD, 5/16-18 x 1.500 LG, PT	1
13	E29019-00	BUSHING, SLEEVE, 0.323 ID x 0.563 OD, 0.90 LG	1
14	E29012-00	ROLLER, 0.575 ID x 1.000 OD, 0.850 LG	1
15	E84204-00	BOLT, HEX HD, M6-1 x 30mm LG, SS	1
16	E83550-00	NUT, HEX, M6-1, NYLOC, ZINC	1
17	E28861-00	BRACKET, ACTUATOR MOUNT	1
18	E28618-00	NUT, HEX, 1/4-20, NYLOC, SS	2

ORBITAL PAD DRIVER AND MANIFOLD DIAGRAM

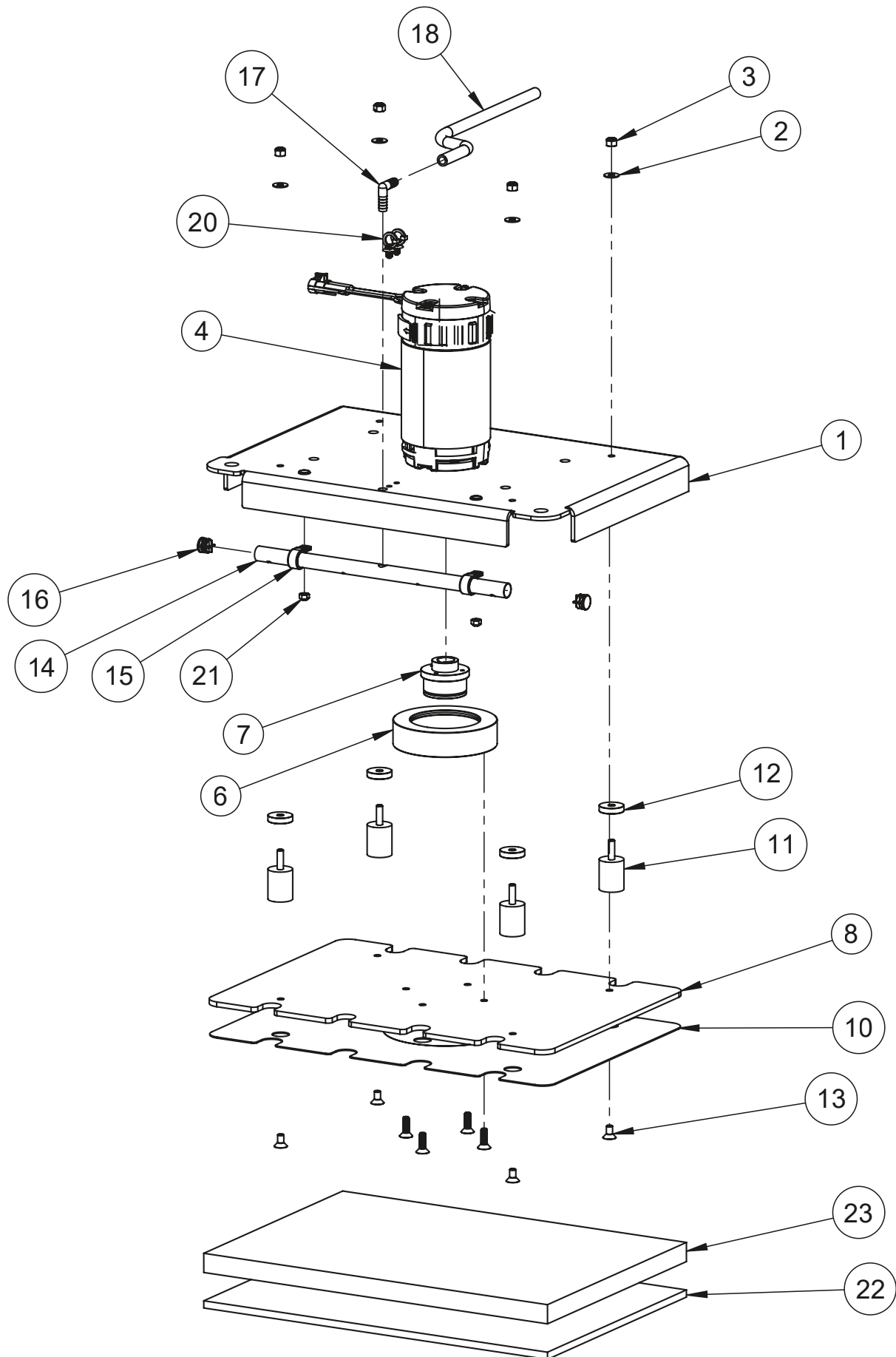

ORBITAL PAD DRIVER AND MANIFOLD PARTS LISTING

Item#	Part #	Description	Qty.
1	E28896-00	FRAME, ORBITAL HEAD, 20in, WELDMENT	1
2	E28622-00	WASHER, FLAT, 0.344 ID x 0.750 OD, 0.050 THK, SS	5
3	E28624-00	NUT, HEX, 5/16-18, NYLOC, SS	4
4	E28521-00	MOTOR, 24VDC, 2200 RPM, 0.75 HP	1
5	E28635-00	MACHINE KEY, 8mm x 7mm x 28mm, ROUNDED	1
6	E28525-00	BEARING HUB, ORBITAL	1
7	E29025-00	BEARING HUB, ECCENTRIC (0.85" OFFSET)	1
8	E28897-00	PAD DRIVER, 20in ORBITAL	1
9	E28763-00	SCREW, FLAT HD HEX, 5/16-18 x 1.000 LG, BO	4
10	E28899-00	FACE, PAD DRIVER, 20in ORBITAL	1
11	E28530-00	ISOLATOR MOUNT, 1.563 TALL x 1.250 DIA, RUBBER	4
12	E28633-00	SPACER, 0.328 ID x 1.250 OD, ZINC	4

Item#	Part #	Description	Qty.
13	E28639-00	SCREW, FLAT HD HEX, 5/16-18 x 0.625 LG	4
14	E28898-00	MANIFOLD, WATER FEED	1
15	E28534-00	LOOP CLAMP, 0.75 DIA	2
16	E28535-00	HOLE PLUG, 0.59-0.70 DIA	2
17	E28536-00	FITTING, ELBOW 90, 3/8 BARB x 3/8 BARB, PLASTIC	1
18	EP50231-00	TUBE, 0.375 ID, CLEAR PVC, 18.00 LG	1
19	E28621-00	WIRE TIE PUSH MOUNT	2
20	E83523-00	CABLE TIE, 4.125 LG x 0.125 W	2
21	E28853-00	NUT, HEX, 1/4-20, FLEX-TOP LOCK, CDPL	2
22	E84057-00	FLOOR PAD, 20in x 14in, MAROON	1
23	E89831-00	FLOOR PAD, 20in x 14in, RED	1

SOLUTION DELIVERY DIAGRAM

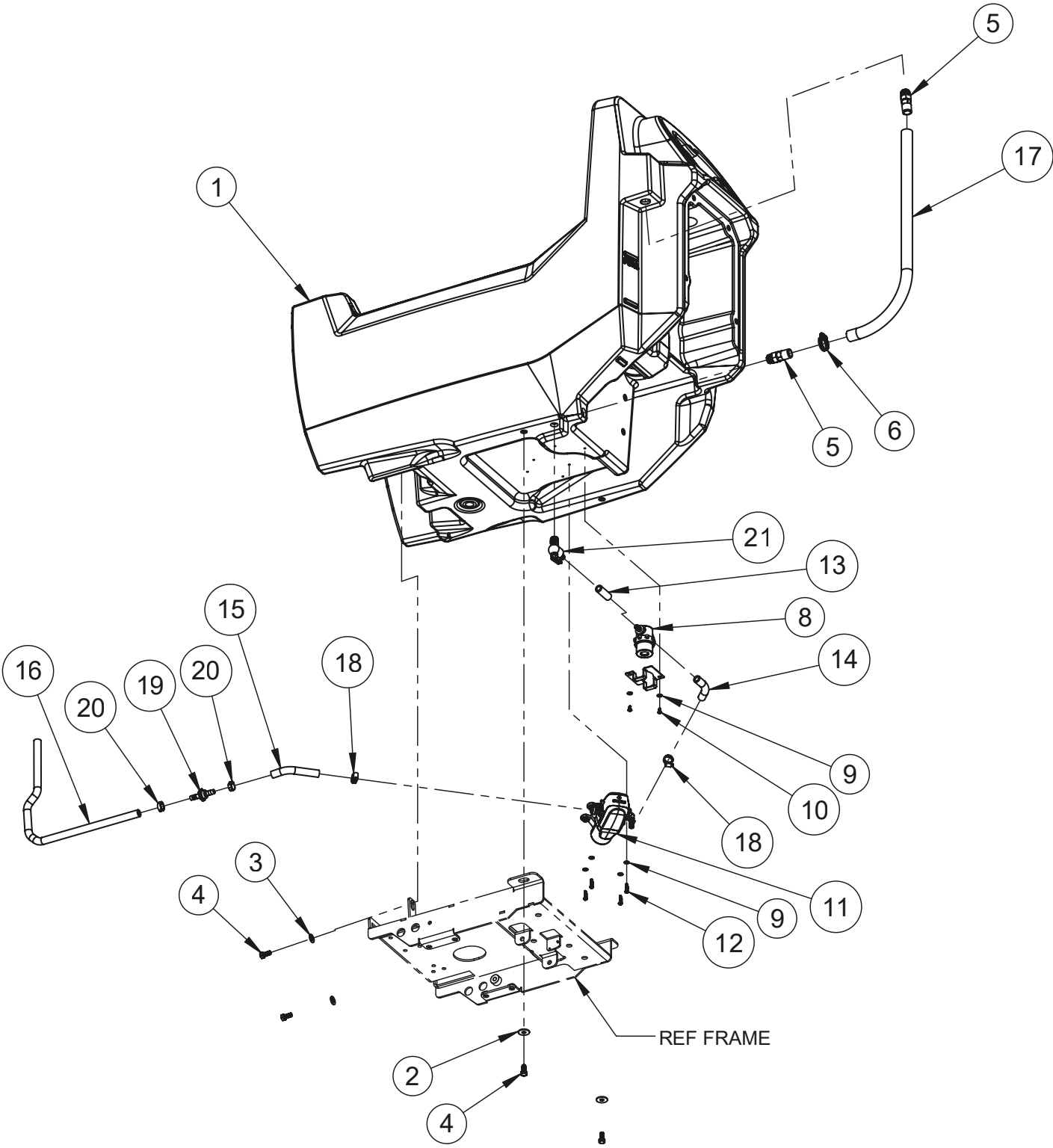

SOLUTION DELIVERY PARTS LISTING

Item#	Part #	Description	Qty.	Item#	Part #	Description	Qty.
1	E28889-00	SOLUTION TANK WITH INSERTS AND CUTOUTS	1	12	E28761-00	SCREW, PAN HD TORX, #8-16 TF x 0.750 LG	4
2	E29388-00	WASHER, FLAT, 0.344 ID x 1.000 OD, 0.062 THK	2	13	EP50224-00	HOSE, 0.375 ID, REINFORCED CLEAR PVC, 1.50 LG	1
3	E29403-00	WASHER, FLAT, 0.344 ID x 0.750 OD, 0.057 THK	2	14	EP50226-00	HOSE, 0.375 ID, REINFORCED CLEAR PVC, 3.25 LG	1
4	E81089-00	BOLT, HEX HD, 5/16-18 x 0.750 LG, ZP	4	15	EP50227-00	HOSE, 0.375 ID, REINFORCED CLEAR PVC, 4.25 LG	1
5	E28913-00	FITTING, ADAPTER, 3/4 BARB x 1/2 NPT, PLASTIC	2	16	EP50229-00	HOSE, 0.375 ID, REINFORCED CLEAR PVC, 31.00 LG	1
6	E28766-00	CLAMP, HOSE, 0.680-1.250 DIA	1	17	EP50230-00	TUBE, 0.750 ID, CLEAR PVC, 24.00 LG	1
7	E28740-00	BRACKET, STRAINER-CHEM PUMP	1	18	E89720-00	CLAMP, HOSE, 0.438 - 0.782 DIA	2
8	E28942-00	STRAINER, IN-LINE	1	19	E28816-00	CHECK VALVE, 3/8 BARB, PLASTIC	1
9	E28775-00	WASHER, FLAT, 0.203 ID x 0.438 OD, 0.040 THK, SS	6	20	E28773-00	CLAMP, HOSE, SINGLE PINCH	2
10	E29334-00	SCREW, PAN HD TORX, #8-16 TF x 0.375 LG	2	21	E28999-00	FITTING, BALL VALVE, 90, 3/8 BARB x 3/8 NPT, PLASTIC	1
11	E28902-00	PUMP, WATER, 0.7 gpm	1				

FRONT COVER DIAGRAM

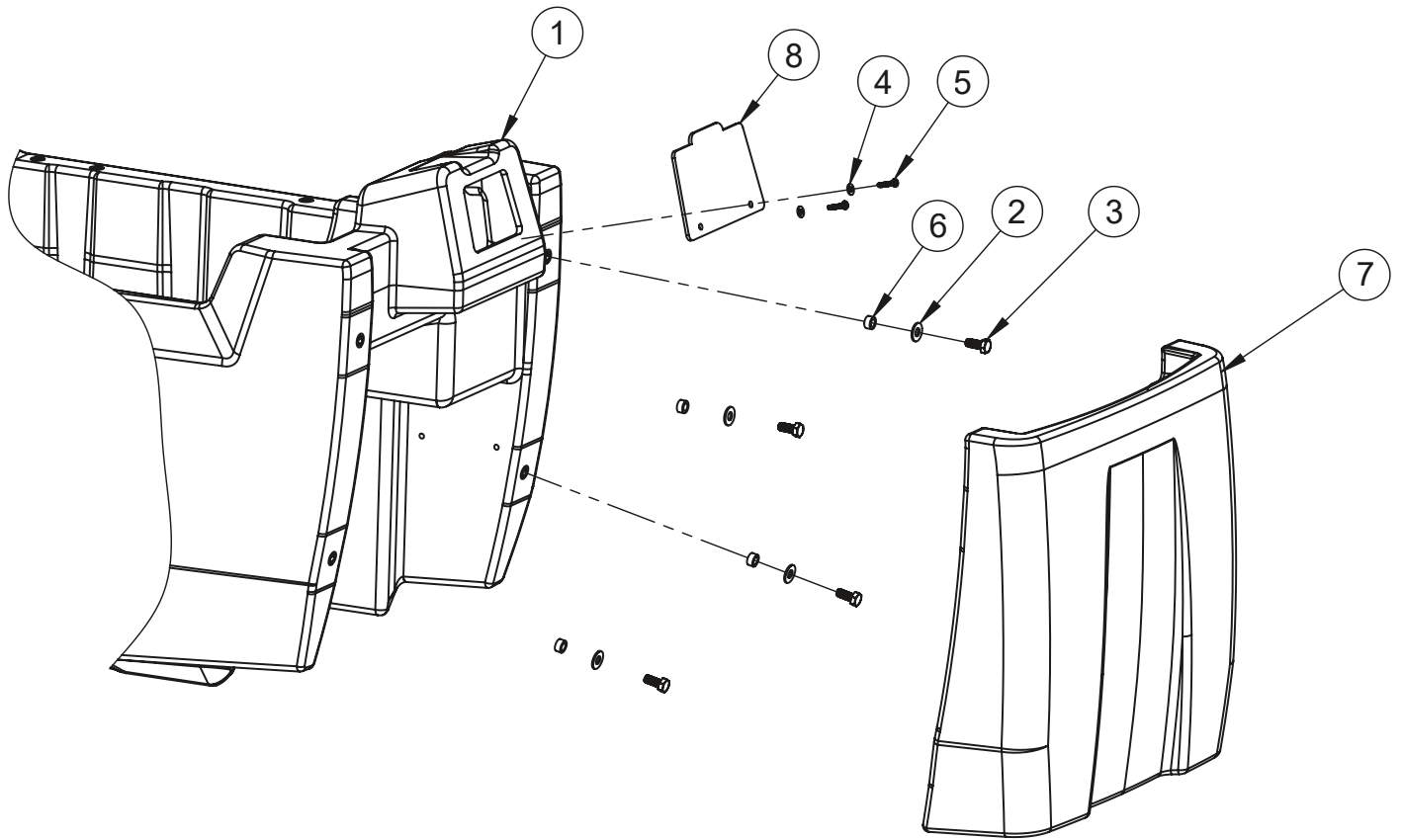

FRONT COVER PARTS LISTING

Item#	Part #	Description	Qty.	Item#	Part #	Description	Qty.
1	E28889-00	SOLUTION TANK WITH INSERTS AND CUTOUTS	1	6	E29579-00	BUSHING, SLEEVE, 0.315 ID x 0.500 OD, 0.250 LG, OIB	4
2	E29403-00	WASHER, FLAT, 0.344 ID x 0.750 OD, 0.057 THK	4	7	E28888-00	FRONT COVER, SOLUTION TANK w/ CUTOUTS	1
3	E81089-00	BOLT, HEX HD, 5/16-18 x 0.750 LG, ZP	4	8	E28825-00	COVER, FRONT FILL PORT	1
4	E28775-00	WASHER, FLAT, 0.203 ID x 0.438 OD, 0.040 THK, SS	2	9	E29392-00	BOLT, HEX HD, 5/16-18 x 1.000 LG	1
5	E28761-00	SCREW, PAN HD TORX, #8-16 TF x 0.750 LG	2	10	E12524-00	NUT, HEX, 5/16-18, SS	1

SOLUTION TANK, REAR DIAGRAM

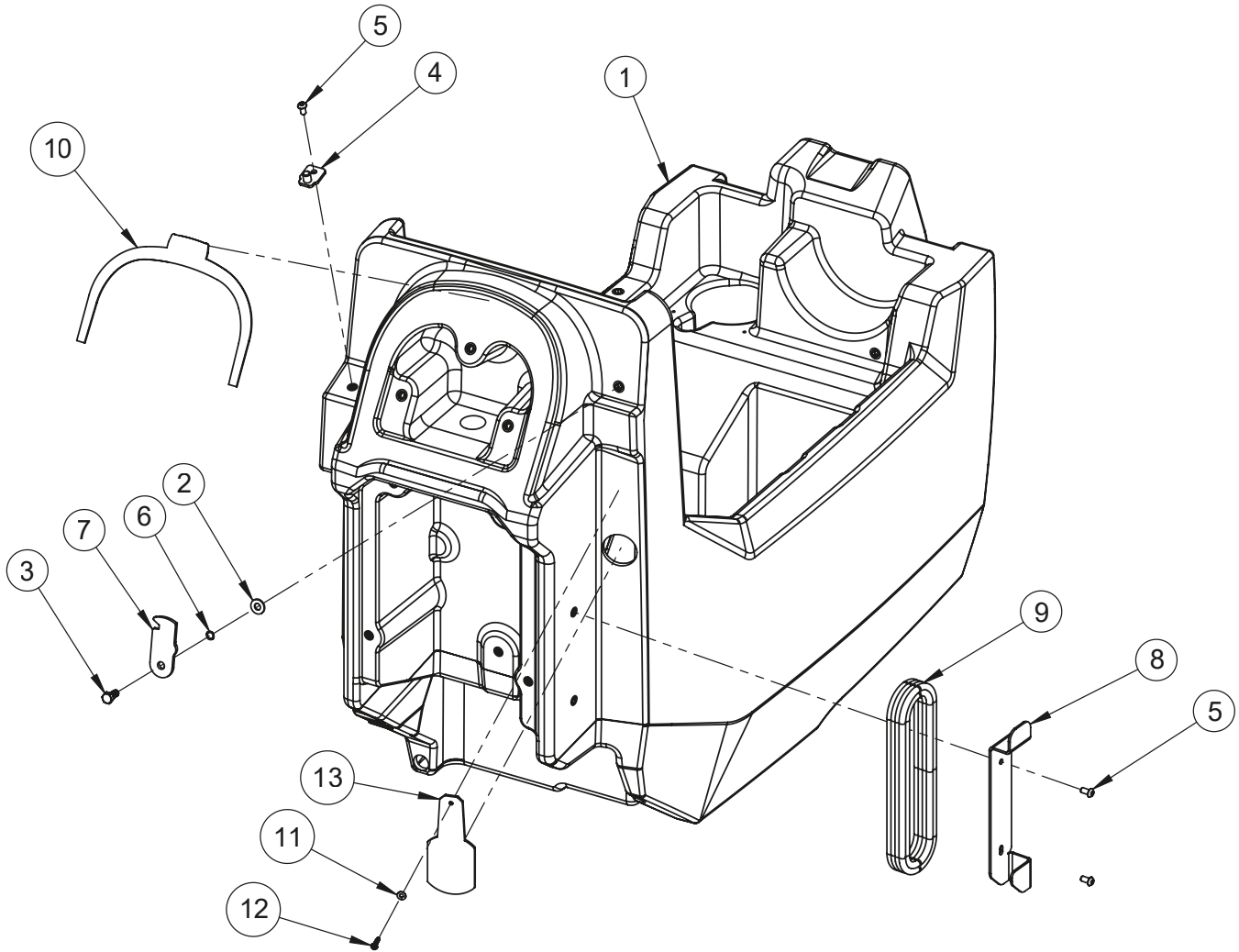

SOLUTION TANK, REAR PARTS LISTING

Item#	Part #	Description	Qty.	Item#	Part #	Description	Qty.
1	E28889-00	SOLUTION TANK WITH INSERTS AND CUTOUTS	1	8	E28737-00	BRACKET, CHARGER CORD WRAP	1
2	E29403-00	WASHER, FLAT, 0.344 ID x 0.750 OD, 0.057 THK	1	9	E28704-00	ELECTRICAL CORD, BATTERY CHARGER	1
3	E81089-00	BOLT, HEX HD, 5/16-18 x 0.750 LG, ZP	1	10	E28823-00	GASKET, GENESYS CONSOLE HANDLE	1
4	E28712-00	HANGER, DRAIN CUFF	1	11	E28775-00	WASHER, FLAT, 0.203 ID x 0.438 OD, 0.040 THK, SS	1
5	E28648-00	SCREW, BUTTON HD HEX, 1/4-20 X 0.500 LG	3	12	E28761-00	SCREW, PAN HD TORX, #8-16 TF x 0.750 LG	1
6	E28765-00	WASHER, LOCK, 0.320 ID x 0.437 OD, WAVE, ZP	1	13	E28837-00	COVER, REAR FILL PORT	1
7	E28707-00	HANGER, SQUEEGEE	1				

RECOVERY TANK DIAGRAM

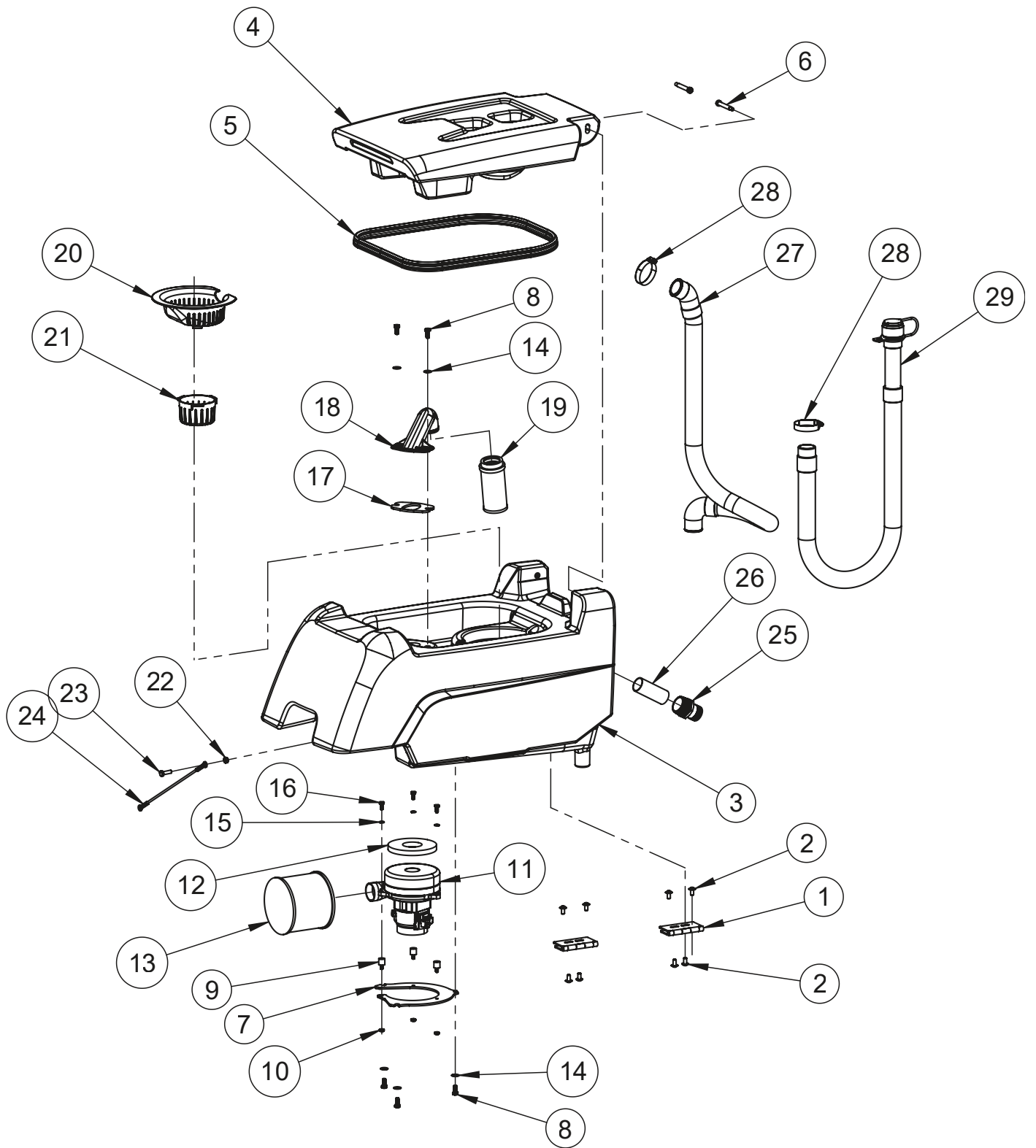

RECOVERY TANK PARTS LISTING

Item#	Part #	Description	Qty.	Item#	Part #	Description	Qty.
1	E28596-00	HINGE, 4.000 LEAF HT	2	16	E10734-00	BOLT, HEX HD, 1/4-20 x 0.625 LG, ZP	3
2	E29569-00	SCREW, FLANGED BUTTON HD HEX, 5/16-18 x 0.625 LG, SS	8	17	E28607-00	GASKET, FLOAT MOUNT	1
3	E28886-00	RECOVERY TANK WITH INSERTS AND CUTOUTS	1	18	E29562-00	MOUNT, FLOAT BALL CAGE	1
4	E28885-00	COVER, RECOVERY TANK WITH CUTOUT	1	19	E29563-00	CAGE, FLOAT BALL	1
5	EP50294-00	SEAL, RECOVERY TANK LID	1	20	E29525-00	DEBRIS TRAY	1
6	E29558-00	BOLT, SOC HD HEX, 5/16-18 x 2.250 LG, 0.375 DIA x 2.250 LG SHOULDER	2	21	E29561-00	HOLDER, DEFOAMING CHEMICAL PUCK	1
7	E28995-00	BRACKET, VACUUM MOUNT	1	22	E12524-00	NUT, HEX, 5/16-18, SS	1
8	E81089-00	BOLT, HEX HD, 5/16-18 x 0.750 LG, ZP	5	23	E29392-00	BOLT, HEX HD, 5/16-18 x 1.000 LG	1
9	E28914-00	ISOLATOR, 1/4 TAP, 1/4 STUD	3	24	E28760-00	CABLE, RECOVERY TANK	1
10	E29565-00	NUT, HEX, 1/4-20, THIN, NYLOC	3	25	E29531-00	FITTING, ADAPTER, 1.500 BARB x 1 1/2 NPT, PLASTIC	1
11	E28993-00	VACUUM FAN, 24VDC, 460W	1	26	E29577-00	TUBE, PVC RIGID, 1.500 ID x 1.350 OD, 3.625 LG	1
12	E28608-00	GASKET, FOAM, 2.000 ID x 5.000 OD, 0.500 THK	1	27	E28998-00	HOSE, SQUEEGEE VACUUM	1
13	E28994-00	FILTER, HEPA	1	28	E28755-00	CLAMP, HOSE, 1.560 - 2.500 ID, 0.500 W	2
14	E28622-00	WASHER, FLAT, 0.344 ID x 0.750 OD, 0.050 THK, SS	5	29	E28997-00	HOSE, RECOVERY TANK DRAIN	1
15	E81078-00	WASHER, LOCK, 0.250 ID x 0.487 OD, 0.062 THK, SPLIT, ZP	3				

INNER ELECTRICAL PANEL DIAGRAM

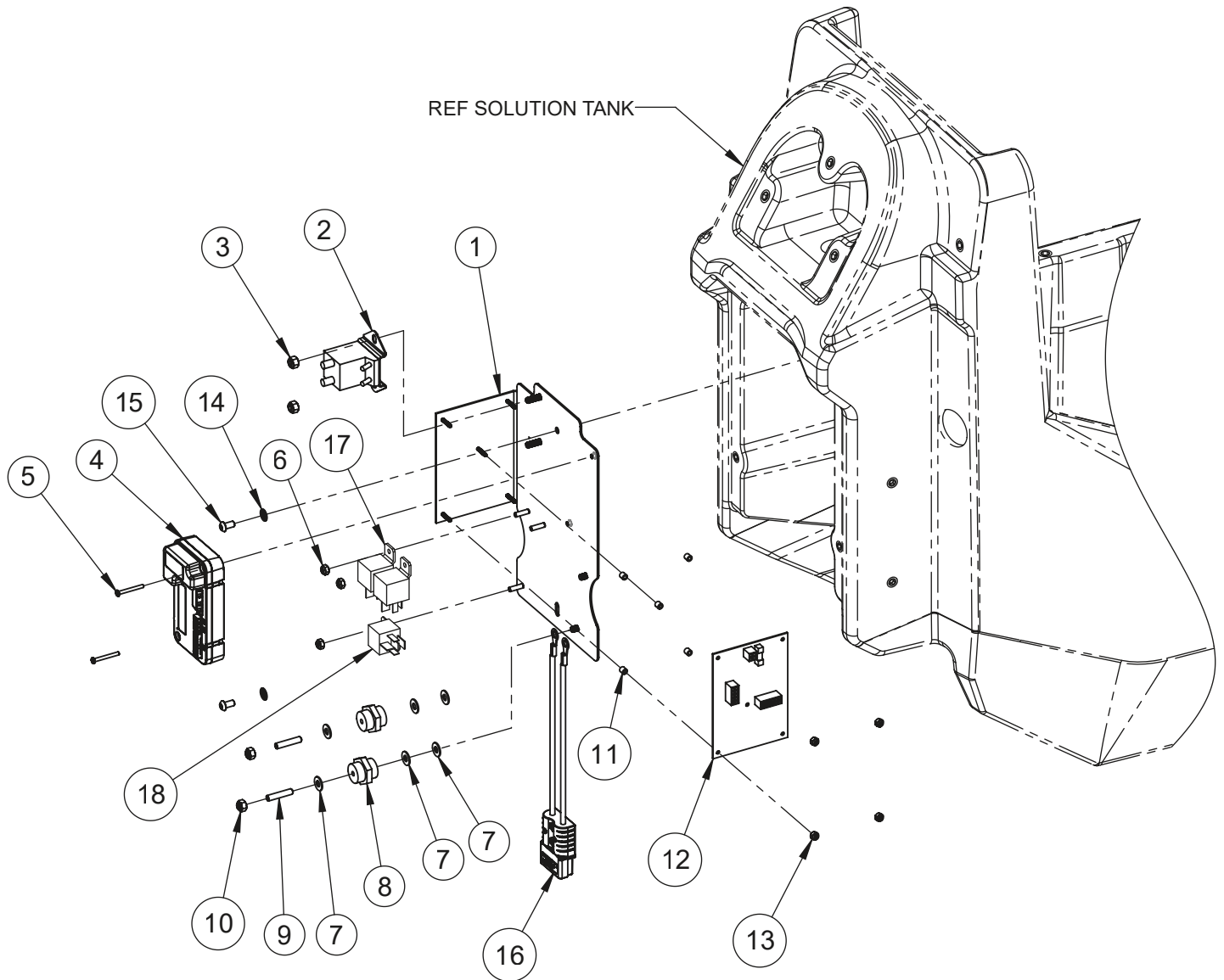

INNER ELECTRICAL PANEL PARTS LISTING

Item#	Part #	Description	Qty.	Item#	Part #	Description	Qty.
1	E28891-00	PANEL, INNER ELECTRICAL, WELDMENT	1	10	E28853-00	NUT, HEX, 1/4-20, FLEX-TOP LOCK, CDPL	2
2	E28924-00	CONTACTOR, 100A 24V	1	11	E29373-00	SPACER, 0.140 ID x 0.250 OD, 0.250 LG	5
3	E28618-00	NUT, HEX, 1/4-20, NYLOC, SS	2	12	E28892-00	CONTROL BOARD, G20 TRACTION DISC/ORBITAL	1
4	E28949-00	CONTROLLER, I-DRIVE	1	13	E29381-00	NUT, HEX, #6-32, NYLOC, ZP	4
5	E29382-00	SCREW, PAN HD PHIL, #6-32 x 1.250 LG	2	14	E29446-00	WASHER, LOCK, 0.256 ID x 0.540 OD, INT TOOTH	2
6	E29366-00	NUT, HEX, #10-32, THIN, NYLOC, ZP	3	15	E28648-00	SCREW, BUTTON HD HEX, 1/4-20 X 0.500 LG	2
7	E28617-00	WASHER, FLAT, 0.281 ID x 0.625 OD, 0.050 THK, SS	6	16	E28979-00	HARNES, CHARGER	1
8	E28950-00	STANDOFF, ELECTRICAL, 1/4-20 FEMALE THREADS	2	17	E28956-00	RELAY, 80A	2
9	E29447-00	SCREW, SET, CUP POINT, 1/4-20 x 1.250 LG	2	18	E28979-00	RELAY, 40A	1

OUTER ELECTRICAL PANEL DIAGRAM

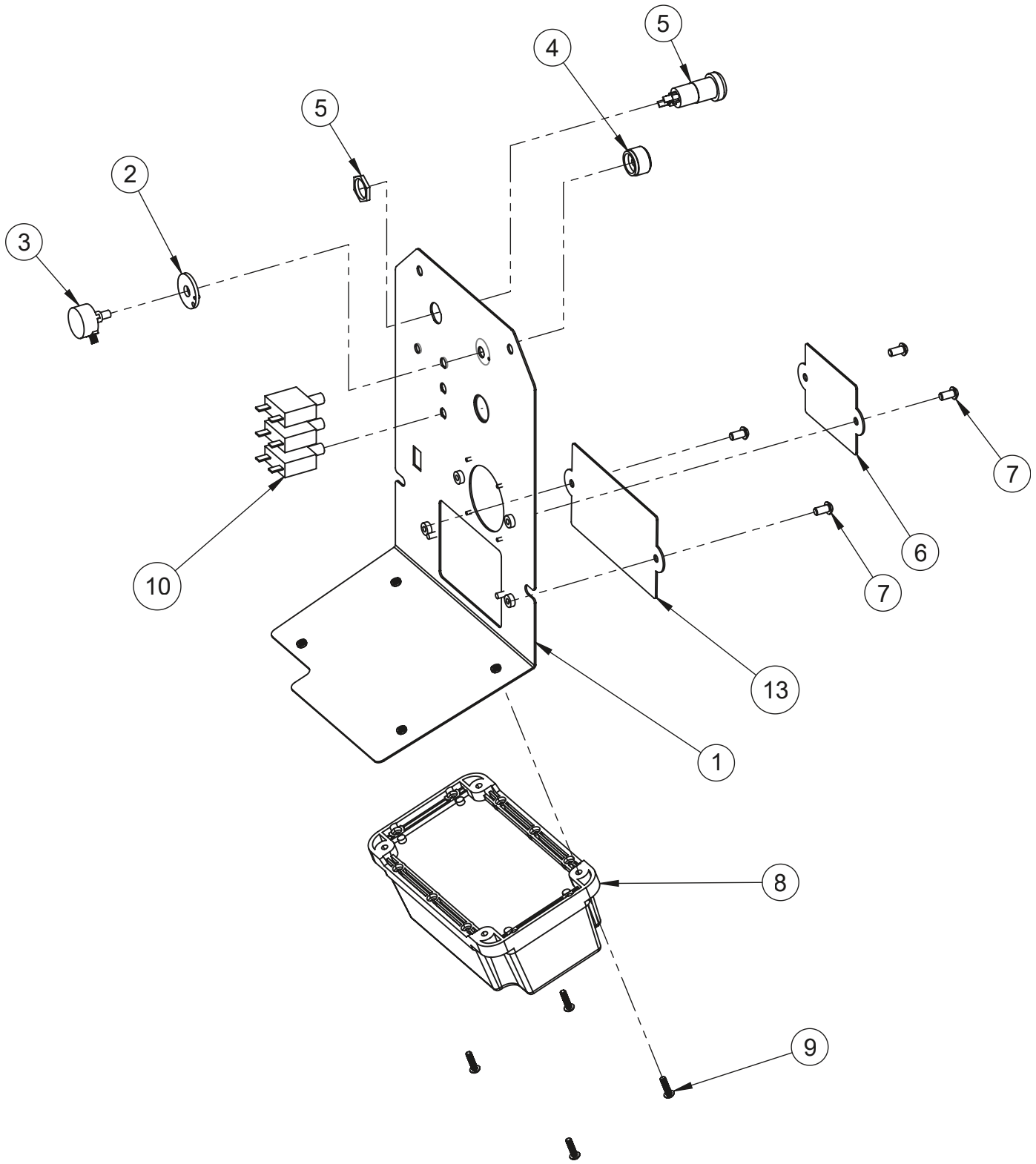

OUTER ELECTRICAL PANEL PARTS LISTING

Item#	Part #	Description	Qty.
1	E28890-00	PANEL, OUTER ELECTRICAL, WELDMENT	1
2	E28768-00	POT SPACER AND PIN ASSEMBLY	1
3	E29706-00	POTENTIOMETER, 5K ohm	1
4	E28606-00	KNOB, KNURLED, 0.250 SHAFT, 0.925 OD, METAL	1
5	E12629-00	SWITCH, KEYED, SPE, WITH 2 KEYS	1
6	E29364-00	PLATE, TIMER COVER	1
7	E28648-00	SCREW, BUTTON HD HEX, 1/4-20 X 0.500 LG	4

Item#	Part #	Description	Qty.
8	E28895-00	CHARGER, PCS 2421	1
9	E28912-00	SCREW, BUTTON HD HEX, #10-32 x 0.750 LG, SS	4
10	E28954-00	BREAKER, 30A	3
11	E29001-00	MACHINE HARNESS, G20 TRACTION ORB	1
12	E29007-00	DECAL, BACK PANEL, 20in	1
13	E29015-00	PLATE, ARMOR COVER	1

HANDLE AND CONSOLE DIAGRAM

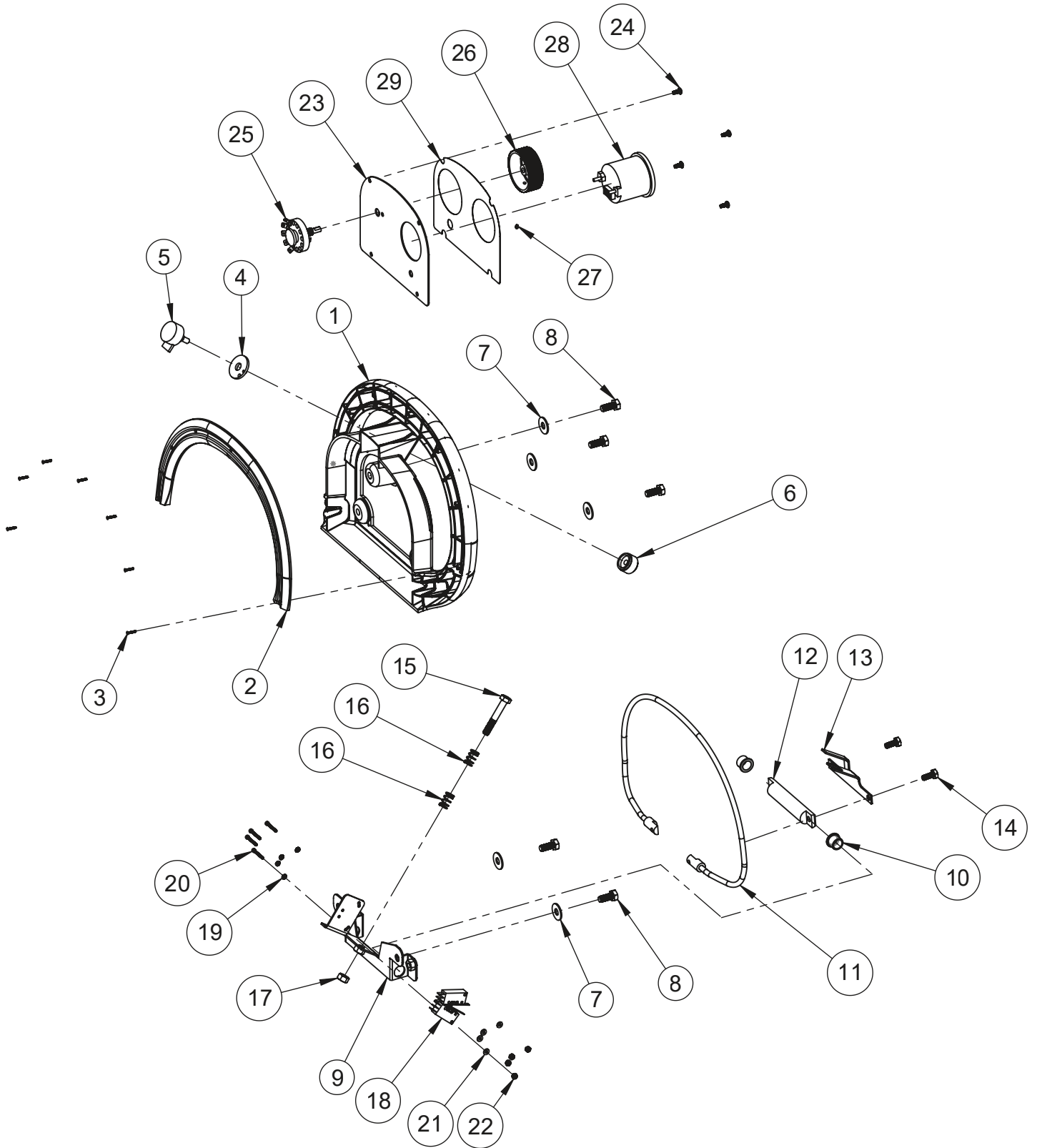

HANDLE AND CONSOLE PARTS LISTING

Item#	Part #	Description	Qty.	Item#	Part #	Description	Qty.
1	E28915-00	HANDLE, CONSOLE CONTROLS, FRONT, GENESYS	1	16	E29328-00	SPRING, COMPRESSION, 0.376 ID x 0.500 OD, 0.750 LG	2
2	E29301-00	HANDLE, CONSOLE CONTROLS, BACK, GENESYS	1	17	E12524-00	NUT, HEX, 5/16-18, SS	1
3	E29336-00	SCREW, FLAT HD TORX, #2 TF x 0.500 LG	7	18	E28833-00	SWITCH, LEVER ACTION, IP67	2
4	E28768-00	POT SPACER AND PIN ASSEMBLY	1	19	E28821-00	WASHER, LOCK, 0.115 ID x 0.260 OD, EXT TOOTH, ZP	4
5	E28955-00	POTENTIOMETER	1	20	E28762-00	SCREW, SOC HD HEX, #4-40 x 1.000 LG, BO	4
6	E28606-00	KNOB, KNURLED, 0.250 SHAFT, 0.925 OD, METAL	1	21	E29368-00	WASHER, FLAT, 0.125 ID x 0.312 OD, 0.030 THK	4
7	E81062-00	WASHER, FLAT, 0.344 ID x 0.875 OD, 0.063 THK, ZP	5	22	E28770-00	NUT, HEX, #4-40, NYLOC	4
8	E81089-00	BOLT, HEX HD, 5/16-18 x 0.750 LG, ZP	5	23	E29322-00	CLUSTER PANEL, STANDARD	1
9	E29325-00	BRACKET, CONTROLS HANDLE, WELDMENT	1	24	E29334-00	SCREW, PAN HD TORX, #8-16 TF x 0.375 LG	4
10	E29337-00	BEARING, SLEEVE, 0.500 ID x 0.750 OD, 0.500 LG	2	25	E29323-00	SWITCH, ROTARY	1
11	E29335-00	HANDLE BAIL WELDMENT	1	26	E29324-00	KNOB, 2.200 OD x 0.830 HT, KNURLED	1
12	E29326-00	BAIL PIVOT	1	27	E28788-00	SCREW, SET, CUP POINT, #5-40 x 0.188 LG	1
13	E29327-00	ARM, HANDLE BAIL	1	28	E12630-00	GAUGE, BDI (BATTERY DISCHARGE, HOUR)	1
14	E10734-00	BOLT, HEX HD, 1/4-20 x 0.625 LG, ZP	2	29	E28794-00	DECAL, CONTROL PANEL, STANDARD	1
15	E29329-00	BOLT, HEX HD, 5/16-18 x 2.000 LG	1				

SQUEEGEE LIFT LEVER DIAGRAM

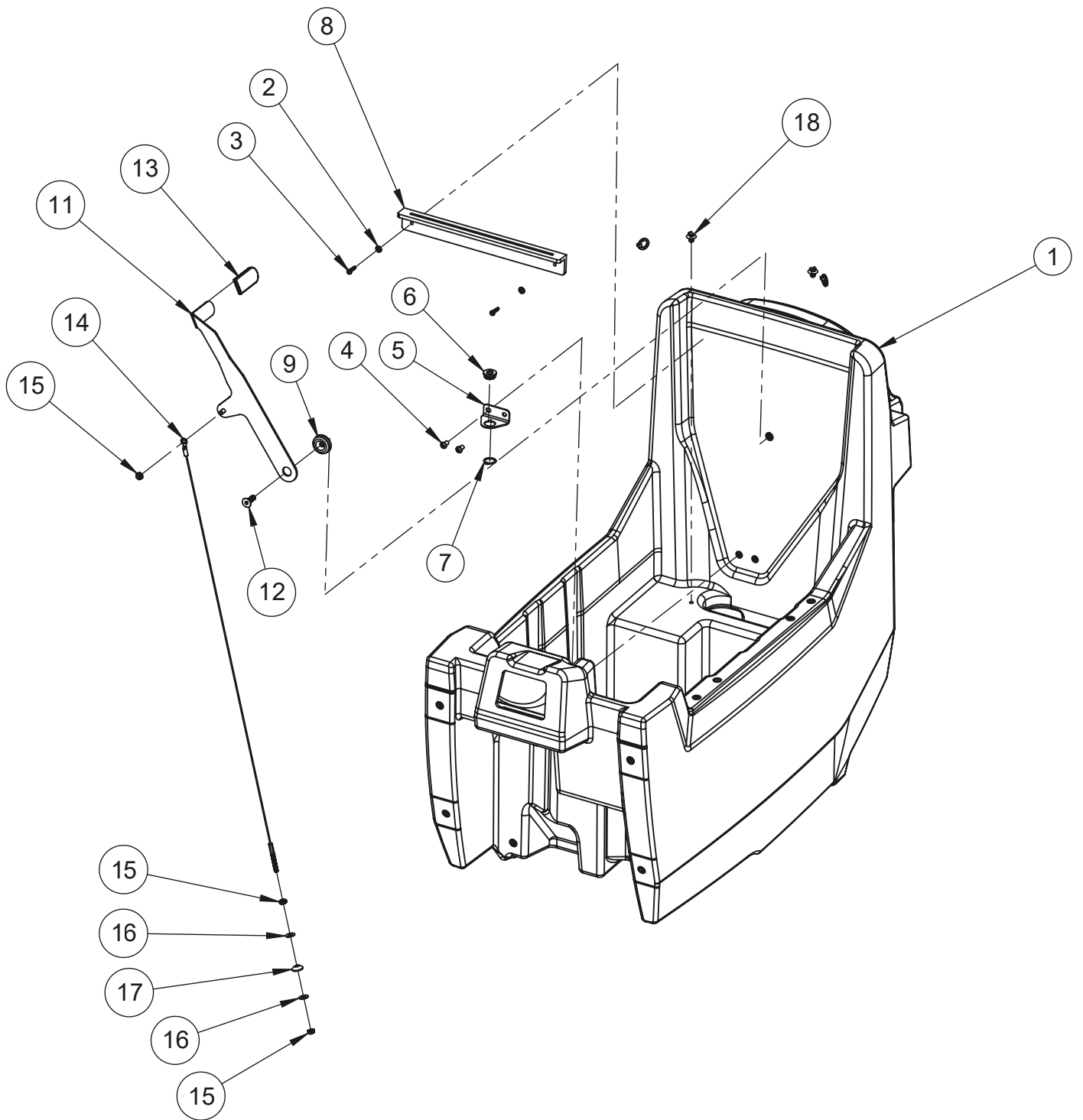

SQUEEGEE LIFT LEVER PARTS LISTING

Item#	Part #	Description	Qty.	Item#	Part #	Description	Qty.
1	E28889-00	SOLUTION TANK WITH INSERTS AND CUTOUTS	1	11	E29013-00	LEVER, SQUEEGEE LIFT, WELDMENT	1
2	E28775-00	WASHER, FLAT, 0.203 ID x 0.438 OD, 0.040 THK, SS	2	12	E28763-00	SCREW, FLAT HD HEX, 5/16-18 x 1.000 LG, BO	1
3	E28761-00	SCREW, PAN HD TORX, #8-16 TF x 0.750 LG	2	13	E28721-00	CAP, SQUEEGEE LEVER	1
4	E28648-00	SCREW, BUTTON HD HEX, 1/4-20 X 0.500 LG	2	14	E29014-00	SQUEEGEE LIFT CABLE ASSY	1
5	E28714-00	BRACKET, CABLE GUIDE	1	15	E29565-00	NUT, HEX, 1/4-20, THIN, NYLOC	3
6	E28715-00	CABLE GUIDE	1	16	E28617-00	WASHER, FLAT, 0.281 ID x 0.625 OD, 0.050 THK, SS	2
7	E28722-00	RETAINING RING, EXTERNAL, 0.75 SHAFT X 0.046 GROOVE	1	17	E28717-00	WASHER, SPHERICAL, 0.280 ID x 0.750 OD, ZP	1
8	E28992-00	GUIDE, SQUEEGEE LEVER, GENESYS 20	1	18	E28621-00	WIRE TIE PUSH MOUNT	2
9	E28718-00	BUSHING, SQUEEGEE LEVER	1	19	E83523-00	CABLE TIE, 4.125 LG x 0.125 W	2
10	E28719-00	WASHER, FLAT, 0.656 ID x 1.312 OD, 0.094 THK, NYLON	1				

SQUEEGEE DIAGRAM

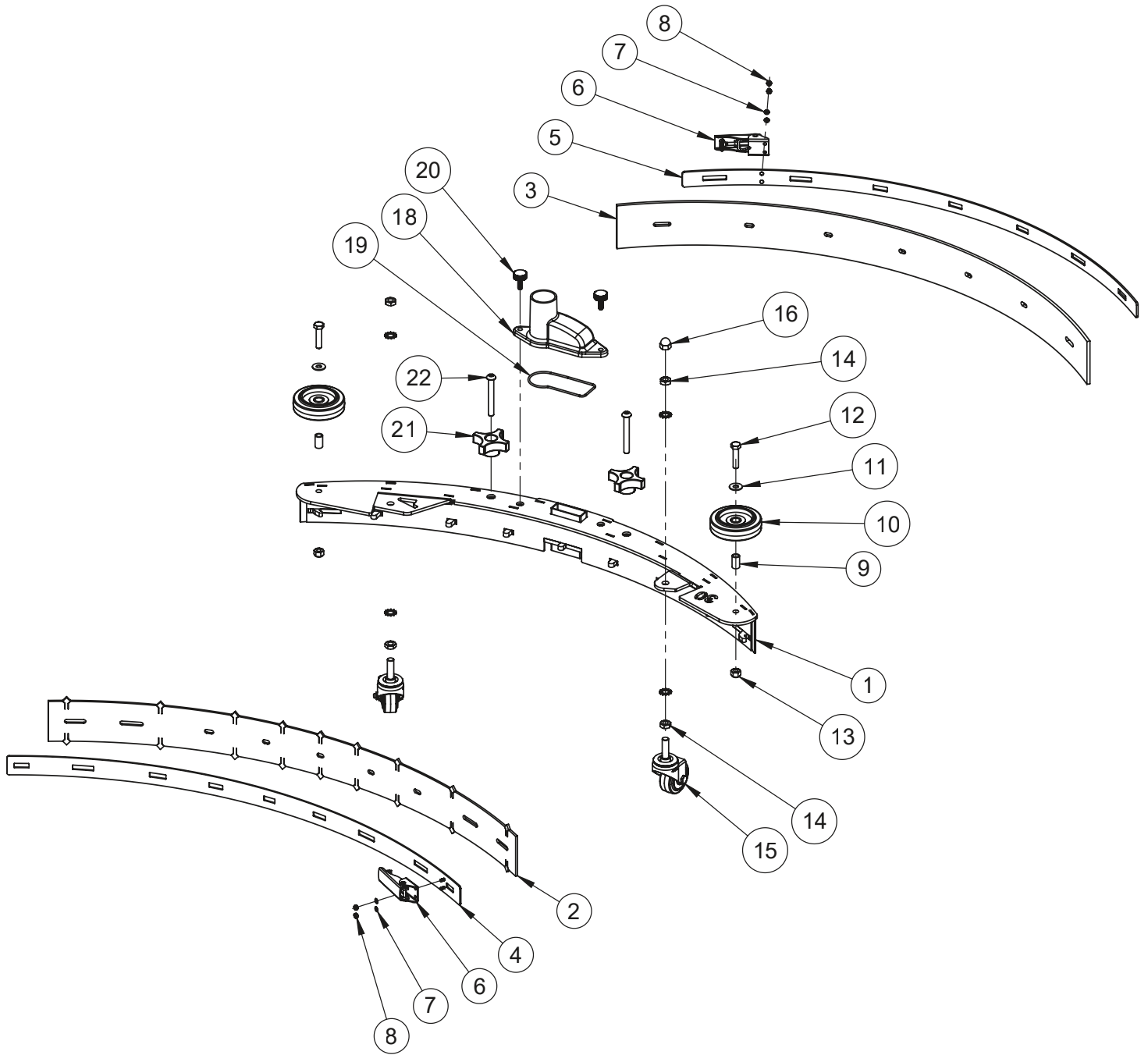

SQUEEGEE PARTS LISTING

Item#	Part #	Description	Qty.	Item#	Part #	Description	Qty.
1	E28871-00	SQUEEGEE WELDMENT, 30.5in	1	12	E29553-00	BOLT, HEX HD, 5/16-18 x 1.375 LG, SS	2
2	E28872-00	BLADE, FRONT SQUEEGEE, 30.5in	1	13	E28624-00	NUT, HEX, 5/16-18, NYLOC, SS	2
3	E28873-00	BLADE, REAR SQUEEGEE, 30.5in	1	14	E29398-00	NUT, HEX, 5/16-16, THIN, ZP	4
4	E28874-00	CLAMP ASSEMBLY, FRONT SQUEEGEE, 30.5in	1	15	E28568-00	CASTER, SWIVEL, STUD MOUNT, 2in	2
5	E28875-00	CLAMP ASSEMBLY, REAR SQUEEGEE, 30.5in	1	16	E28851-00	NUT, ACORN HEX, 3/8-16, NYLON (BLACK)	1
6	E29521-00	CLAMP, OVER CENTER	2	17	E29050-00	WASHER, LOCK, 0.384 ID x 0.694 OD, EXT TOOTH, ZP	4
7	E28806-00	WASHER, LOCK, 0.141 ID x 0.295 OD, INT TOOTH, SS	4	18	E28908-00	DRIP TRAP, SQUEEGEE	1
8	E29397-00	NUT, HEX, #6-32, SS	4	19	E28754-00	O-RING, SIZE - 151, VITON	1
9	E28656-00	BUSHING, 0.313 ID x 0.439 OD, 0.750 HT, BRONZE	2	20	E29554-00	SCREW, THUMB, 1/4-20 x 0.750 LG, SS	2
10	EP50279-00	WHEEL, COLSON ROLLER, 3in	2	21	E28903-00	KNOB, 4-ARM, 5/16-18 HOLE, PLASTIC	2
11	E28622-00	WASHER, FLAT, 0.344 ID x 0.750 OD, 0.050 THK, SS	2	22	E29547-00	SCREW, BUTTON HD HEX, 5/16-18 x 2.500 LG	2

BATTERY OPTIONS DIAGRAM

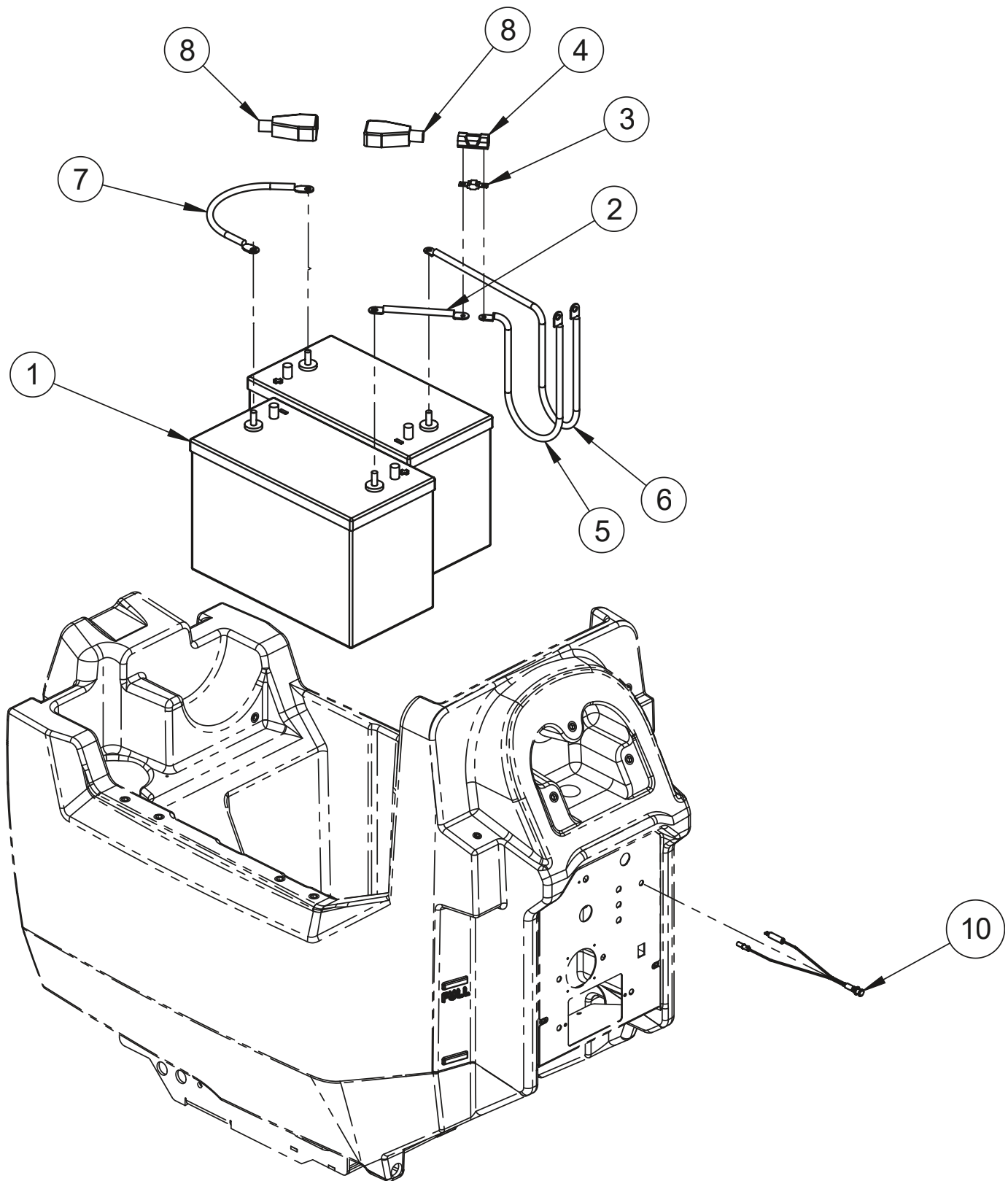

BATTERY OPTIONS PARTS LISTING

Item#	Part #	Description	Qty.
1	E88030-00	BATTERY, AGM, 12 VDC 110 AH, CROWN 12CRV110	2
1	E11767-00	BATTERY, WET, 12 VDC 130 AH, CROWN 31HDC	2
1	E28887-00	BATTERY, 12 VDC 150 AH, WET, TROJAN T-1275	2
2	E29204-00	BATTERY CABLE, 5in, RED	1
3	E28975-00	FUSE, 100A	1
4	E28974-00	FUSE HOLDER	1

Item#	Part #	Description	Qty.
5	E29023-00	BATTERY CABLE, 17in, RED	1
6	E29022-00	BATTERY CABLE, 21in, BLACK	1
7	E29203-00	BATTERY CABLE, 12in, BLACK	1
8	E12543-00	TERMINAL PROTECTOR, RED STRAIGHT	2
9	E29004-00	KIT, WET BATTERY PROTECTION, G20	1
10	E29344-00	ASSEMBLY, LED INDICATOR	1

SOLICHEM™ OPTION DIAGRAM

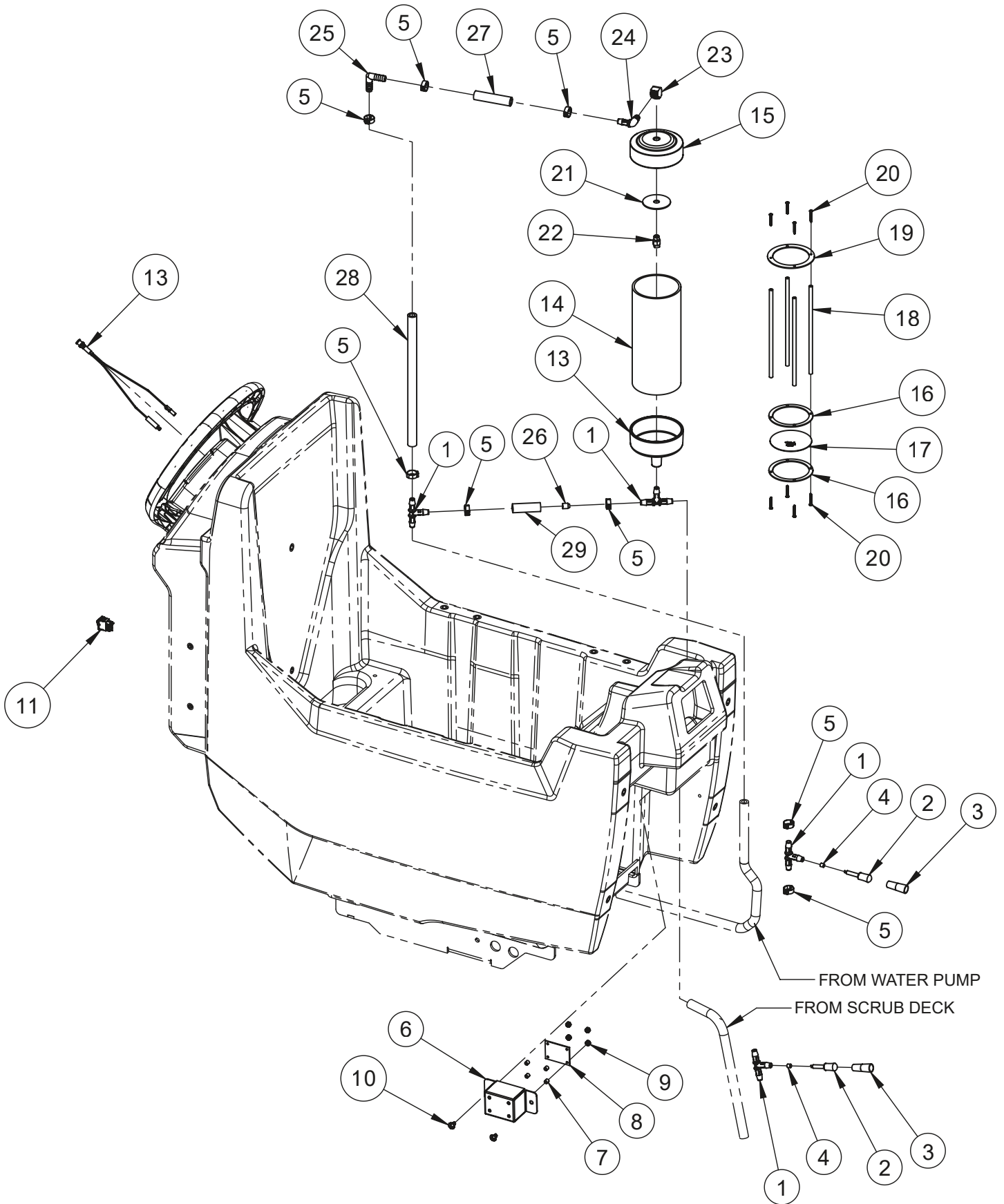

SOLICHEM™ OPTION PARTS LISTING

Item#	Part #	Description	Qty.	Item#	Part #	Description	Qty.
1	E29315-00	FITTING, TEE, 3/8 BARB, PLASTIC	4	16	E29308-00	FLANGE, INNER PUCK CAGE	2
2	E28774-00	SENSOR, CONDUCTIVITY 1/4" PROBE DIA	2	17	E29309-00	SCREEN, PUCK CAGE, SS	1
3	E28827-00	HEAT SHRINK, 0.500 ID, BLACK	2	18	E29310-00	ROD, 0.25 OD, PVC, GRAY, 7.25" LG	4
4	E29020-00	TUBING, 0.156 ID x 0.250 OD, LATEX RUBBER, BLACK	2	19	E28757-00	FLANGE, INNER PUCK CAGE, TOP	1
5	E28773-00	CLAMP, HOSE, SINGLE PINCH	8	20	E29311-00	SCREW, PAN HD TORX, #4-20 TF x 0.875 LG, SS	8
6	E28778-00	BRACKET, TDS SHEILD	1	21	E28767-00	WASHER, FENDER, 0.406 ID x 1.250 OD, 0.069 THK	1
7	E29373-00	SPACER, 0.140 ID x 0.250 OD, 0.250 LG	4	22	E29313-00	FITTING, NOZZLE, BRASS	1
8	E28784-00	PCB, TDS SENSOR	1	23	E29320-00	FITTING, ELBOW 90, 1/4 NPT, BRASS	1
9	E29381-00	NUT, HEX, #6-32, NYLOC, ZP	4	24	E28786-00	FITTING, ELBOW 90, 3/8 BARB x 1/4 NPT	1
10	E29018-00	SCREW, ROUND HD PHIL, 1/4-10 TF x 0.375 LG, ZP	2	25	E28536-00	FITTING, ELBOW 90, 3/8 BARB x 3/8 BARB, PLASTIC	1
11	E28781-00	SWITCH, ROCKER, BLACK	1	26	E29345-00	FITTING, RESTRICTION PLUG	1
12	E29344-00	ASSEMBLY, LED INDICATOR	1	27	EP50225-00	HOSE, 0.375 ID, REINFORCED CLEAR PVC, 2.75 LG	1
13	E29316-00	CAP, CHEM TUBE END, BOTTOM	1	28	EP50228-00	HOSE, 0.375 ID, REINFORCED CLEAR PVC, 10.75 LG	1
14	E29306-00	TUBE, CLEAR PVC	1	29	EP50224-00	HOSE, 0.375 ID, REINFORCED CLEAR PVC, 2.00 LG	1
15	E29307-00	CAP, CHEM TUBE END, TOP	1				

TIMER AND ARMOR™ OPTIONS DIAGRAM

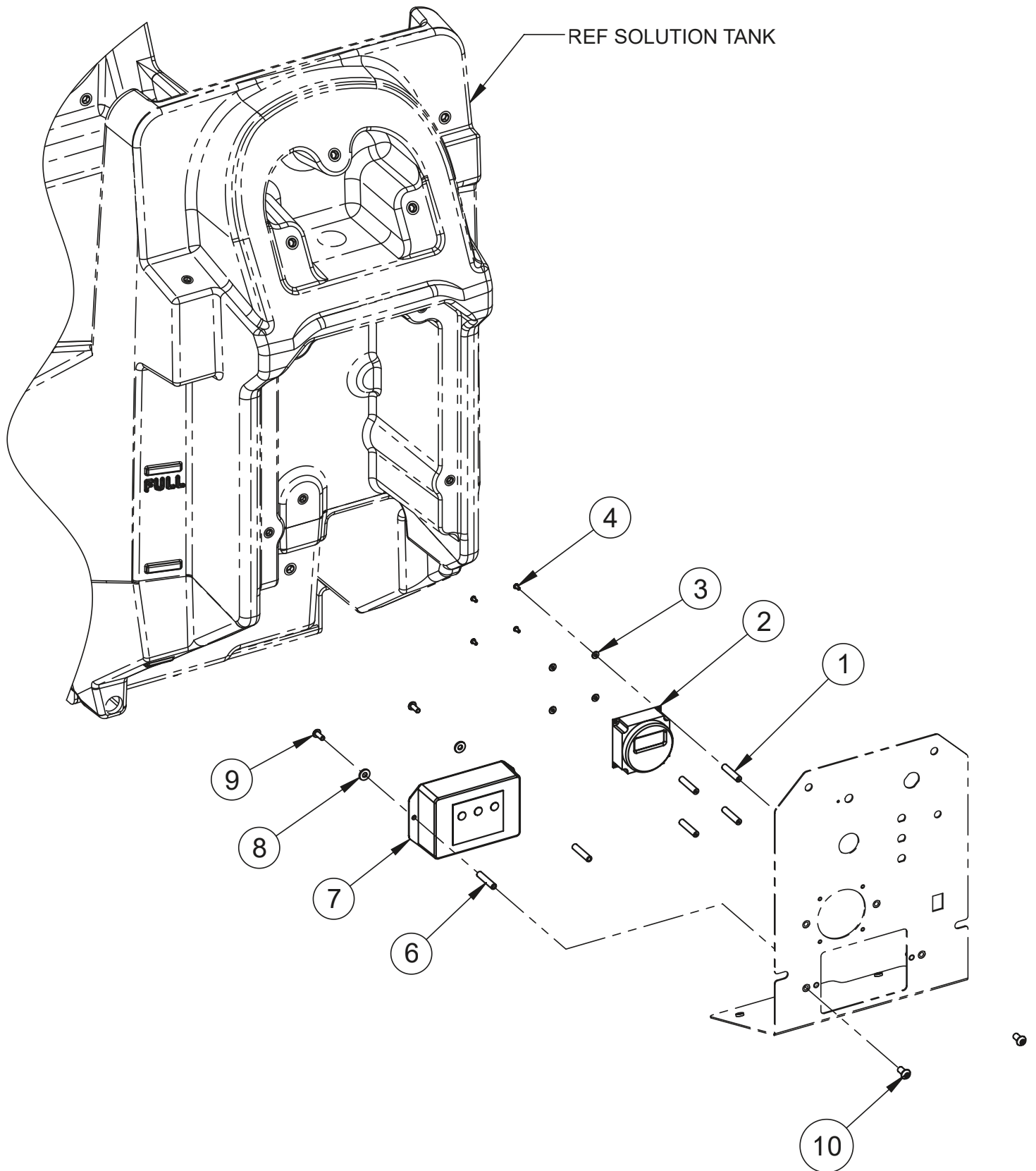

TIMER AND ARMOR™ OPTIONS PARTS LISTING

Item#	Part #	Description	Qty.
1	E29374-00	STANDOFF, #4-40, 0.250 OD, 1.250 LG	4
2	E28966-00	MACHINE TIMER	1
3	E29368-00	WASHER, FLAT, 0.125 ID x 0.312 OD, 0.030 THK	4
4	E29369-00	SCREW, BUTTON HD HEX, #4-40 x 0.250 LG, ZP	4
5	E28976-00	MACHINE TIMER HARNESS	1

Item#	Part #	Description	Qty.
6	E29375-00	STANDOFF, #10-32, 0.250 OD, 1.250 LG	2
7	E28965-00	ARMOR BATTERY PROTECTION DEVICE	1
8	E29580-00	WASHER, FLAT, 0.210 ID x 0.500 OD, 0.050 THK	2
9	E29367-00	SCREW, BUTTON HD HEX, #10-32 x 0.500 LG, ZP	2
10	E28648-00	SCREW, BUTTON HD HEX, 1/4-20 X 0.500 LG	2

GENESYS™ RECOMMENDED SERVICE PARTS

PART #	PART NAME	DIAGRAM	WEAR ITEM	20D	200RB	OPTIONAL PARTS
E29459-00	STATIC STRAP	FRAME	X	X	X	
E28872-00	BLADE, FRONT SQUEEGEE, 30.5in	SQUEEGEE	X	X	X	
E28873-00	BLADE, REAR SQUEEGEE, 30.5in	SQUEEGEE	X	X	X	
E28903-00	KNOB, 4-ARM, 5/16-18 HOLE, PLASTIC	SQUEEGEE		X	X	
E28784-00	PCB, TDS SENSOR	SOLICHEM™ OPTION		X	X	
E28899-00	FACE, PAD DRIVER, 20in ORBITAL	ORBITAL PAD DRIVER AND WATER MANIFOLD			X	
E89831-00	FLOOR PAD, 20in x 14in, RED	ORBITAL PAD DRIVER AND WATER MANIFOLD	X		X	
E28530-00	ISOLATOR MOUNT, 1.563 TALL x 1.250 DIA, RUBBER	ORBITAL PAD DRIVER AND WATER MANIFOLD			X	
E28633-00	SPACER, 0.328 ID x 1.250 OD, ZINC	ORBITAL HEAD			X	
E28531-00	ISOLATOR BUSHING, 0.313 ID x 1.250 OD, PVC BLUE	ORBITAL HEAD LIFT BRACKETS			X	
E28656-00	BUSHING, 0.313 ID x 0.439 OD, 0.750 HT, BRONZE	ORBITAL HEAD LIFT BRACKETS			X	
E28887-00	BATTERY, 12 VDC 150 AH, WET, TROJAN T-1275	BATTERY OPTIONS	X	X	X	X
E88030-00	BATTERY, AGM, 12 VDC 110 AH, CROWN 12CRV110	BATTERY OPTIONS	X	X	X	X
E11767-00	BATTERY, WET, 12 VDC 130 AH, CROWN 31HDC	BATTERY OPTIONS	X	X	X	X
E28704-00	ELECTRICAL CORD, BATTERY CHARGER	SOLUTION TANK, REAR		X	X	
E28881-00	SHROUD, DISC HEAD w/ CUTOUTS, 20in	DISC HEAD		X		
E28858-00	ASSEMBLY, PAD DRIVER, 20in	DISC HEAD	X	X		
E28994-00	FILTER, HEPA	RECOVERY TANK	X	X	X	
E29563-00	CAGE, FLOAT BALL	RECOVERY TANK		X	X	
E29562-00	MOUNT, FLOAT BALL CAGE	RECOVERY TANK		X	X	
E29525-00	DEBRIS TRAY	RECOVERY TANK	X	X	X	
E28902-00	PUMP, WATER, 0.7 gpm	SOLUTION DELIVERY	X	X	X	
E29561-00	HOLDER, DEFOAMING CHEMICAL PUCK	RECOVERY TANK	X	X	X	
E29313-00	FITTING, NOZZLE, BRASS	SOLICHEM™ OPTION	X	X	X	X
F092486	SOLICHEM / DEFOAMER COMBO		X	X	X	X
E28975-00	FUSE, 100A	BATTERY OPTIONS	X	X	X	
E28954-00	BREAKER, 30A	OUTER ELECTRICAL PANEL		X	X	
E12629-00	SWITCH, KEYED, SPE, WITH 2 KEYS	OUTER ELECTRICAL PANEL		X	X	
E28956-00	RELAY, 80A	INNER ELECTRICAL PANEL		X	X	
E28979-00	RELAY, 40A	INNER ELECTRICAL PANEL		X	X	
E28895-00	CHARGER, PCS 2421	OUTER ELECTRICAL PANEL		X	X	
E29525	DEBRIS TRAY	RECOVERY TANK	X	X	X	
E29601	PUMP	SOLUTION DELIVERY	X	X	X	
EP50276	CHEM PUCK CAGE	SOLUTION DELIVERY	X	X	X	
E29313	SPRAY NOZZLE	SOLUTION DELIVERY	X	X	X	
F092486	SOLICHEM/DEFOAMER COMBO	SOLUTION DELIVERY		X	X	
E28975	FUSE	ELECT. ENCLOSURE	X	X	X	
E28954	30A BREAKER	ELECT. ENCLOSURE		X	X	
E12629	KEY SWITCH W/ 2 KEYS	ELECT. ENCLOSURE		X	X	
E28956	80A RELAY	ELECT. ENCLOSURE		X	X	
E28978	40A RELAY	ELECT. ENCLOSURE		X	X	
E28907	PCS CHARGER	ELECT. ENCLOSURE		X	X	

GENESYS™ RECOMMENDED MAINTENANCE

SYSTEM	REFERENCE SECTION	DAILY	WEEKLY	MONTHLY	SIX MONTHS
CONTROL PANEL					
INSPECT ALL CONTROLS AND HARDWARE FOR SECURITY & SERVICEABILITY	PARTS DIAGRAMS	x			
VERIFY PROPER OPERATION OF ALL CONTROLS	ALL	X			
SOLUTION DISTRIBUTION					
VERIFY SOLUTION FLOW AND ADJUSTMENT OPERATION	SOLUTION DISTRIBUTION	X			
CLEAN AND INSPECT INLINE FILTER	SOLUTION DISTRIBUTION			X	
FLUSH TANK WITH FRESH WATER	SOLUTION DISTRIBUTION			X	
SCRUB DECK					
RINSE BRUSHES AND PADS	SCRUB DECK SETUP	X			
RINSE AND DRY SCRUB DECK	SCRUB DECK SETUP	X			
CLEAN MOTOR VENTS	PARTS DIAGRAMS			X	
INSPECT INSOLATORS (ORBITAL ONLY)	PARTS DIAGRAMS				X
INSPECT LIFT LINKAGE AND PIVOTS	SCRUB DECK SETUP				X
RECOVERY SYSTEM					
RINSE OUT AND LET THE RECOVERY TANK AIR DRY	RECOVERY SYSTEM	X			
CLEAN AND INSPECT DEBRIS TRAY	RECOVERY SYSTEM	X			
VERIFY DRAIN HOSE CAP IS SEALED TIGHT WHEN INSTALLED	RECOVERY SYSTEM	X			
INSPECT LID SEAL	RECOVERY SYSTEM		X		
INSPECT/REPLACE DEFOAMER PUCK AS NEEDED	RECOVERY SYSTEM		X		
INSPECT HEPA FILTER	RECOVERY SYSTEM				X
CLEAN AND SANITIZE RECOVERY TANK	RECOVERY SYSTEM			X	
BATTERIES AND CHARGER					
INSPECT CABLES & TERMINALS FOR CORROSION, SECURITY & DAMAGE	BATTERIES			X	
SERVICE LEAD ACID BATTERIES IF APPLICABLE	BATTERIES		X		
CLEAN ONBOARD CHARGER VENTS IF APPLICABLE	PARTS DIAGRAMS			X	
INSPECT WET BATTERY PROTECTION SYSTEM	BATTERIES				X
SQUEEGEE ASSEMBLY					
CLEAN AND INSPECT THE BLADES AND ENTIRE SQUEEGEE ASSEMBLY	RECOVERY SYSTEM	X			
INSPECT VACUUM HOSE	RECOVERY SYSTEM		X		
FRAME AND CHASSIS COMPONENTS					
CLEAN AND INSPECT WHEELS AND CASTORS	PARTS DIAGRAMS			X	
CLEAN AND INSPECT LINKAGE, CHASSIS AND HARDWARE	PARTS DIAGRAMS			X	
CLEAN AND INSPECT VISIBLE WIRES FOR DAMAGE AND SECURITY	PARTS DIAGRAMS				X

TROUBLESHOOTING GUIDE

ISSUE	POTENTIAL CAUSE	PROPOSED SOLUTION	MANUAL SECTION
INSUFFICIENT WATER TO SCRUB HEAD	SOLUTION SETTING TOO LOW	ADJUST SOLUTION CONTROL	SOLUTION DISTRIBUTION
	SOLUTION TANK IS EMPTY	ADD WATER TO THE SOLUTION TANK	SOLUTION DISTRIBUTION
	SOLUTION TUBE IS KINKED OR CLOGGED	INSPECT TUBES	SOLUTION DISTRIBUTION
	SOLUTION SHUTOFF VALVE IS CLOSED	OPEN VALVE	SOLUTION DISTRIBUTION
	SOLUTION PUMP IS NOT FUNCTIONING	VERIFY OPERATION AND/OR REPLACE PUMP	PARTS DIAGRAM
	STRAINER SCREEN IS CLOGGED	CLEAN OUT STRAINER BOWL AND SCREEN	PARTS DIAGRAM
POOR WATER RECOVERY	RECOVER TANK IS FULL	EMPTY RECOVERY TANK	RECOVERY SYSTEM
	DIRTY OR WORN SQUEEGEE BLADES	INSPECT/ROTATE/REPLACE AS REQUIRED	RECOVERY SYSTEM
	RECOVERY HOSE LOOSE OR KINKED	INSPECT/REPAIR/REPLACE	RECOVERY SYSTEM
	RECOVERY HOSE OR SQUEEGEE IS OBSTRUCTED	CLEAR OBSTRUCTION FOR SYSTEM	RECOVERY SYSTEM
	SQUEEGEE ASSEMBLY MAY BE OUT OF ADJUSTMENT	ADJUST AS NECESSARY	RECOVERY SYSTEM
	STUCK OR DAMAGED BALL FLOAT	INSPECT/REPAIR OR REPLACE	RECOVERY SYSTEM
	RECOVERY TANK LID IS NOT SEALING PROPERLY	INSPECT SEAL AND REPLACE IF DAMAGED	PARTS DIAGRAM
	DRAIN HOSE CAP IS NOT INSTALLED PROPERLY	INSTALL DRAIN HOSE SECURELY	RECOVERY SYSTEM
	CLOGGED HEPA FILTER	REMOVE AND INSPECT INSIDE AND OUTSIDE OF HEPA FILTER. REPLACE IF DAMAGED.	PARTS DIAGRAM
	LOW BATTERY VOLTAGE	CHARGER BATTERIES	CHARGING
MACHINE WILL NOT TURN ON	FAULTY KEY SWITCH	DIAGNOSE AND REPLACE	WIRING DIAGRAM
	DISCHARGED BATTERIES	CHARGE BATTERIES	CHARGING
	LOOSE OR DAMAGED WIRE/CONNECTION	ADJUST THE MIXTURE AS REQUIRED	SOLUTION DISTRIBUTION
MACHINE IS NOT CLEANING PROPERLY	WORN PAD OR BRUSH	INSPECT AND REPLACE AS REQUIRED	SCRUB DECK SETUP
	WRONG PAD OR BRUSH FOR APPLICATION	CONTACT YOUR LOCAL DISTRIBUTOR FOR RECOMMENDED APPLICATION	SCRUB DECK SETUP
	INSUFFICIENT CLEANING SOLUTION FOR APPLICATION	ADJUST THE MIXTURE AS REQUIRED	SOLUTION DISTRIBUTION
VACUUM MOTOR WILL NOT SHUT OFF	STILL IN DELAY MODE	ALLOW 7 SECONDS TO SHUT DOWN	RECOVERY SYSTEM
	VACUUM RELAY MAY BE FAULTY	CONTACT SERVICE TECHNICIAN TO TROUBLESHOOT AND ISOLATE	WIRING DIAGRAM
SCRUB HEAD WILL NOT RUN	SCRUB HEAD WILL NOT RAISE	LOWER SCRUB HEAD	SCRUB DECK SETUP
	BATTERY PROTECTION IS INDICATING LOW WATER	SERVICE THE BATTERIES	BATTERIES
	BATTERIES ARE LOWER THAN ALLOWABLE	CHARGE BATTERIES	CHARGING
	CIRCUIT BREAKER FOR THE BRUSH MOTORS IS TRIPPED	SEE THE NEXT SECTION TITLED "SCRUB HEAD CIRCUIT BREAKERS"	TROUBLESHOOTING TABLE
	BAIL SWITCH IN HANDLE MAY BE FAULTY	INSPECT AND REPLACE AS REQUIRED	PARTS DIAGRAM
	BATTERY RELAY MAY BE FAULTY	CONTACT SERVICE TECHNICIAN TO TROUBLESHOOT AND ISOLATE	WIRING DIAGRAM
SCRUB HEAD CIRCUIT BREAKER IS TRIPPED	INADEQUATE SOLUTION FOR APPLICATION	INCREASE SOLUTION TO SCRUB HEAD	PRE-USE SETUP
	SCRUB HEAD IS SET ON HEAVY DOWN PRESSURE	REDUCE DOWN PRESSURE SETTING	PRE-USE SETUP
	PAD IS TOO AGGRESSIVE FOR APPLICATION	CONTACT YOUR LOCAL DISTRIBUTOR FOR RECOMMENDED APPLICATION	PRE-USE SETUP
	FAULTY OR SHORTED WIRE	REPAIR	WIRING DIAGRAM
MACHINE WILL NOT DRIVE	WEAK CIRCUIT BREAKER	CONTACT SERVICE TECHNICIAN TO TROUBLESHOOT AND ISOLATE. THE CIRCUIT BREAKER SHOULD NOT TRIP BELOW IT'S STATED RATING.	PARTS DIAGRAM
	CIRCUIT BREAKER MAY BE TRIPPED	INSPECT AND RESET. IF PROBLEM PERSISTS CONTACT YOUR SERVICE TECHNICIAN	PRE-USE SETUP
	BATTERY METER IS FLASHING A FAULT CODE	REFERENCE FAULT CODE AND TROUBLESHOOT AS REQUIRED	PRE-USE SETUP
	BATTERIES DISCHARGED TOO LOW	CHARGE THE BATTERIES	CHARGING
	SPEED KNOB TURNED ALL THE WAY DOWN	INCREASE SPEED SETTING	DRIVE SYSTEM
	FAULTY CONTROLLER	CONTACT SERVICE TECHNICIAN TO TROUBLESHOOT AND ISOLATE	WIRING DIAGRAM
RUN TIME IS SHORT	FAULTY WIRING	CONTACT SERVICE TECHNICIAN TO TROUBLESHOOT AND ISOLATE	WIRING DIAGRAM
	BATTERIES ARE LOW ON WATER(LEAD ACID ONLY)	SERVICE BATTERIES	BATTERIES
	CHARGER IS NOT PROPERLY SET FOR BATTERIES	SET CHARGER TO BATTERY SPECIFICATIONS	CHARGING
	SCRUB HEAD IS IN HIGH DOWN PRESSURE	REDUCE SCRUB HEAD PRESSURE	PRE-USE SETUP
BATTERY CHARGER IS NOT ABLE TO FINISH CHARGE CYCLE	CONFIRM A STEADY GREEN LIGHT AFTER THE CHARGE CYCLE(BEFORE UNPLUGGING FROM THE OUTLET)	BATTERIES	

BETCO US WARRANTY POLICY

10 year coverage

Subject to the conditions stated below, Betco warrants parts and labor on rotationally molded polyethylene tanks/housings and injection molded vacuum head assemblies to be free from defects in materials and workmanship for a period of ten years to the original purchaser.

3 Year Coverage

Subject to the conditions stated below, Betco warrants parts and labor on all other Betco components to be free from defects in materials and workmanship for a period of three years to the original purchaser.

- Lithium Ion battery for MotoMop™ is a full 3 years

1 Year Coverage

Subject to the conditions stated below, Betco offers a limited warranty for parts and labor on parts and accessories to be free from defects in materials and workmanship for a period of one year to the original purchaser on the following equipment:

- PowerUp™ 14 Upright Vacuum: #E29990-00
- Bac Pac Lite Vacuum: #85903-00
- FiberPRO® Floor Dryer: #85507-00
- WORKMAN™ Series Vacuums: #85024-00, #85025-00, #83012-00, #85027-00
- All Tools and Accessories
- All Battery Chargers
- Deep cycle batteries are pro-rated for 1 year

Allowable Travel Time Warranty Reimbursement:

Battery and propane powered equipment products are eligible for warranty travel time reimbursement while within the warranty period from date of sale to the original purchaser. Warranty period for GeneSys™ Walk-Behind Automatic Scrubber is 180 days; for all other powered equipment products is 90 days. Reimbursement is limited to a maximum 180-mile round trip at 50 cents per mile for warranty consideration.

Propane Machine Warranty:

Kawasaki/Subaru engines are warranted by Kawasaki/Subaru for a period of 2 years against manufacturer defects. All other components (except wear items)* are warranted by Betco for a period of 3 years.

***Wear Items exempt from Warranty consideration include but may not be limited to: power cords, transport wheels, vacuum bags, belts, squeegee blades, pad drivers, clutch plates, handle grips, filters, screens, throttle cables, brushes and carbon brushes.**

Subject to the conditions and exceptions stated in this warranty, Betco warrants the Betco products to be free from defects in material and workmanship, under normal use and service, for the periods listed under the warranty policy to the original purchaser. At any time during the warranty period, Betco will furnish replacement parts for the Betco parts to the original purchaser. Such parts will be furnished and charged including transportation costs, to the original owner through any Betco authorized Service Distributor. If the original part is returned within the warranty policy period from date of delivery for inspection by Betco and is found to be defective, the owner will be credited for the cost of replacement parts plus shipping and handling. Replacement parts that have become defective through wear or abuse are not included in this warranty

This warranty does not apply to damage or defect caused by accident, misuse, negligence, fire, or to any Betco product which has been serviced or repaired by anyone other than an authorized Betco Service Distributor or Betco factory personnel. This warranty is void if products are used for any purpose other than that which was intended. There are no other warranties expressed or implied. In no event shall Betco be liable for incidental or consequential damages or any damage to person or property. (Please note some states do not allow the exclusion or limitations for incidental and consequential damages).

