

AS28

ORDER #86003

28" Automatic Scrubber

FEATURES

- 30 Gallon Solution and Recovery Capacity
- Curved Squeegee Assembly
- "Quick Change" Squeegee Blades
- Enclosed Transaxle - No Belts or Chains
- Electronic Float Shut-off
- Self Propelled Forward and Reverse

The Betco 28" Automatic Floor Scrubber offers a large 30 Gallon Solution/Recovery capacity. The brush pressure is adjustable from 33 to 132 lbs. to handle daily general scrubbing all the way to heavy strip. The 28" width will allow you to clean up to 32,000 sq. ft. per hour. A pad holder comes standard with the machine.

WARRANTY

Tank: 10 Year

Other components: 3 Year*

*Please refer to Betco Equipment Price/Product Guide for complete equipment warranty information.



SPECIFICATIONS

- Volts: 24 Volt System
- Solution Tank: 30 Gallon
- Recovery Tank: 30 Gallon
- Brush Pressure: 33 to 132 lbs.
- Run Time: Approx. 3 hrs.
- Waterlift: 58"
- Weight w/o Batteries: 308 lbs.
- Pad size: 2 - 14" pads
- Dimensions: Length: 65", Width: 30", Height: 40", Squeegee width: 41"

APPLICATIONS

- General Cleaning
- Stripping
- Heavy Duty Scrubbing

OPTIONS

Nylon Brushes #86321

Grit Brushes #86322

Charger #86202

Battery (4) #86277

Authorized Betco Distributor:

Better Solutions Come From...

BETCO[®]

1001 Brown Avenue • P.O. Box 3127 • Toledo, Ohio 43607-0127
©All Rights Reserved 5/99 • Reorder #86003

AS28 28" Automatic Scrubber

Operator's Manual

Order #86003

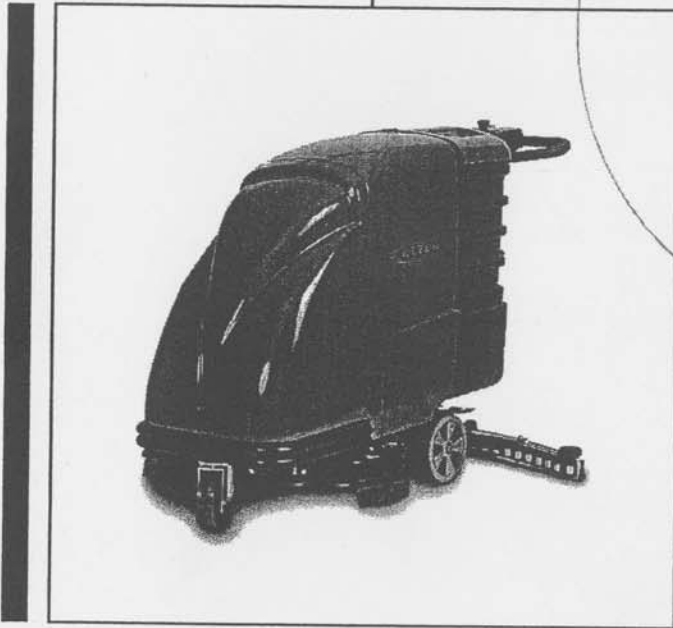

Better Resources. Better Results.
BETCO®

| | | |
|----------|---|---------|
| 1 | GENERAL INFORMATION..... | page 4 |
| 1.1. | PURPOSE OF THE MANUAL..... | page 4 |
| 1.2. | IDENTIFICATION OF THE MACHINE MANUFACTURER..... | page 5 |
| 1.3. | DOCUMENTATION ENCLOSED WITH THE MACHINE..... | page 5 |
| | | |
| 2 | TECHNICAL INFORMATION..... | page 6 |
| 2.1. | GENERAL DESCRIPTION..... | page 6 |
| 2.2. | PRINCIPAL PARTS AND WORK CYCLES | page 6 |
| 2.3. | TECHNICAL SPECIFICATIONS..... | page 9 |
| 2.4. | DIMENSION..... | page 10 |
| 2.5. | DETERGENTS - ADVICE FOR USE | page 10 |
| 2.6. | SAFETY DEVICES..... | page 11 |
| 2.7. | DANGER ZONES..... | page 12 |
| 2.8. | OPTIONAL UNITS | page 12 |
| 2.9. | ACCESSORIES | page 13 |
| | | |
| 3 | SAFETY INFORMATION..... | page 14 |
| 3.1. | SAFETY STANDARDS | page 14 |
| | | |
| 4 | HANDLING AND INSTALLATION..... | page 16 |
| 4.1. | PACKING | page 16 |
| 4.2. | LIFTING AND TRANSPORT | page 16 |
| 4.3. | UNPACKING AND CLEANING | page 16 |
| 4.5. | HANDLE - INSTALLATION..... | page 17 |
| 4.6. | SQUEEGEE - INSTALLATION | page 18 |
| 4.7. | FEEDING BATTERIES | page 18 |
| 4.7.1 | Batteries - Use..... | page 19 |
| 4.7.2 | Batteries - Installation..... | page 19 |
| 4.7.3 | Connecting the batteries | page 20 |
| 4.8. | RECHARGING THE BATTERIES..... | page 20 |
| 4.8.1 | Choosing the battery-charger..... | page 20 |
| 4.8.2 | Batteries - Recharging procedure | page 21 |
| 4.9. | CONNECTING THE DRIVE MOTOR..... | page 22 |
| 4.10. | MANUAL LIFTING AND HANDLING | page 23 |
| 4.10.1 | Anchoring the machine to the vehicle | page 23 |

| | | |
|----------|---|---------|
| 5 | SETTING UP | page 24 |
| 5.1. | SQUEEGEE - ADJUSTMENT | page 24 |
| 5.2. | HANDLE - ADJUSTMENT | page 24 |
| 5.3. | DRAINING OFF DIRTY WATER | page 25 |
| 5.4. | DRAINING AND FILLING WITH WATER AND DETERGENT SOLUTION | page 25 |
| 5.5. | DIRT COLLECTING BOX - REMOVING AND FITTING..... | page 26 |
| 5.6. | BRUSHES - INSTALLATION..... | page 27 |
| 5.7. | PREPARING THE MACHINE FOR WORK | page 28 |

| | | |
|----------|--|---------|
| 6 | USE..... | page 29 |
| 6.1. | DESCRIPTION OF THE CONTROLS | page 29 |
| 6.2. | SQUEEGEE - USE | page 31 |
| 6.3. | PARKING BRAKE - USE | page 31 |
| 6.4. | DRIVING THE MACHINE | page 31 |
| 6.5. | PROCEDURES FOR USING THE MACHINE..... | page 32 |
| 6.6. | RECYCLING SACK ACCESSORY - USE..... | page 34 |
| 6.7. | COMBI ACCESSORY - USE..... | page 35 |
| 6.8. | ADVICE ON OPTIMUM USE OF THE MACHINE | page 36 |

| | | |
|----------|---|---------|
| 7 | MACHINE MAINTENANCE | page 37 |
| 7.1. | MAINTENANCE - GENERAL RULES | page 37 |
| 7.2. | ROUTINE MAINTENANCE..... | page 37 |
| 7.2.1 | General cleaning..... | page 37 |
| 7.2.2 | Suction filter - cleaning | page 37 |
| 7.2.3 | Cleaning liquid input hole - cleaning | page 38 |
| 7.2.4 | Squeegee blades - Replacement..... | page 38 |
| 7.2.5 | FLAPS - Replacement | page 40 |
| 7.2.6 | Dirt collecting scraper - Replacement..... | page 40 |
| 7.2.7 | Diaphragm sack - Replacement..... | page 41 |
| 7.2.8 | Recycle Accessory -Cleaning and replacement | page 41 |
| 7.2.9 | Floater - Cleaning..... | page 42 |
| 7.2.10 | Pump impeller - Cleaning..... | page 42 |
| 7.2.11 | Fuses - Replacement..... | page 42 |
| 7.3. | PERIODIC MAINTENANCE | page 43 |
| 7.3.1 | Daily maintenance | page 43 |
| 7.3.2 | Weekly maintenance..... | page 44 |
| 7.3.3 | Six-monthly maintenance..... | page 44 |
| 7.3.4 | Preparing for long periods of inactivity..... | page 44 |

8 TROUBLESHOOTINGpage 45
8.1. HOW TO OVERCOME ANY PROBLEMSpage 45

All rights reserved.
All duplication, even partial, of the contents of this manual is forbidden, unless authorized in writing by the Manufacturer.

1

GENERAL INFORMATION



Consult this manual carefully before carrying out any operations on the machine⁽¹⁾.

1.1. PURPOSE OF THE MANUAL

This manual has been drawn up by the Manufacturer and is an integral part of the machine equipment.

It defines the purpose for which the machine has been built and contains all the necessary information for operators⁽²⁾.

As well as this manual, which contains the information necessary for users, other publications have been prepared which supply the specific information for maintenance technicians⁽³⁾. Constant observation of the indications guarantees safety for both the operator and the machine, economic running, high quality results and a longer working life of the machine.

Failure to observe the advice may result in damage to persons, to machines, to the floor being washed and to the environment.

For a rapid search of the topics, see the descriptive index at the front of the manual.

Parts of the text that must not be overlooked are shown in bold print and preceded by symbols as illustrated and defined below.



DANGER

Indicates that care must be taken to avoid serious consequences which could even cause death of the operator or possible damage to health.



WARNING

Indicates that care must be taken to avoid serious consequences which could cause damage to the machine or to the environment in which it is working, or economic losses.



INFORMATION

Particularly important indications.

For the purpose of constant development and updating of the product, the manufacturer may make alterations without prior notice.

- (1) The definition "machine" substitutes the trade name to which this manual refers (see cover).
- (2) By this is meant the people whose job it is to use the machine without carrying out any operations that require precise technical skills.
- (3) These are people in possession of experience, technical preparation, knowledge of standards and legislation, who are able to perform the necessary activities and to recognize and avoid possible risks in handling, installation, use and maintenance of the machine.

Even if the machine in your possession is quite different from the illustrations in this document, their safety and the information herein are guaranteed.

1.2. IDENTIFICATION OF THE MACHINE MANUFACTURER (fig. 1)

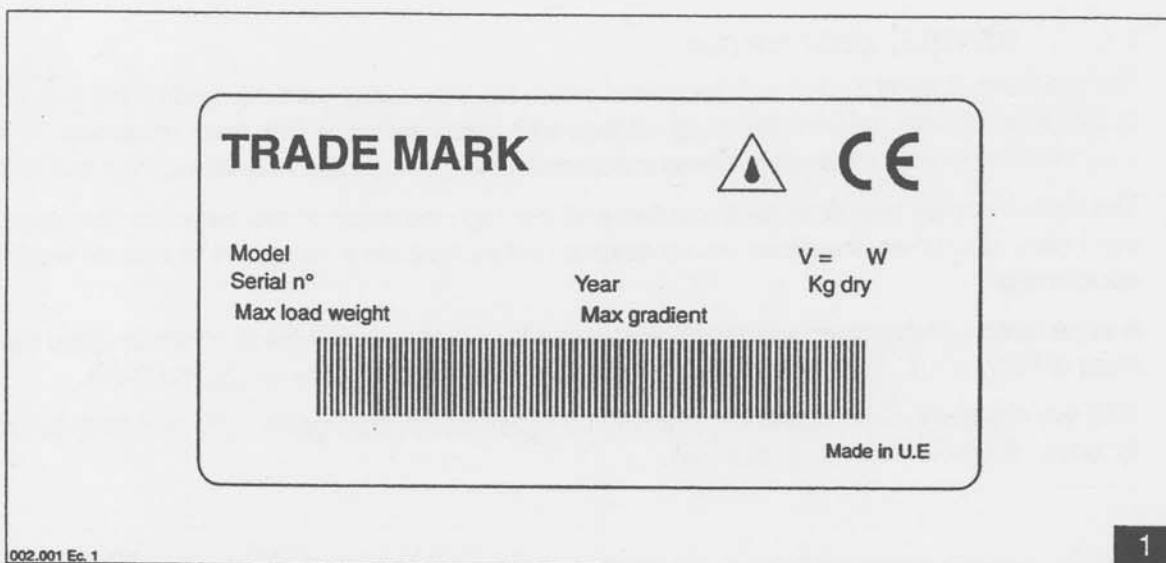

002.001 Ec. 1

The data plate gives:

- The product code.
- The model.
- The voltage.
- Total rated power.
- Serial number.
- Year of manufacture.
- Dry weight.
- Maximum load weight.
- Maximum gradient.
- Bar code with serial number.
- Manufacturer identification.

1.3. DOCUMENTATION ENCLOSED WITH THE MACHINE

- Operator's manual.
- Guarantee certificate.
- Adhesive cards for ordering spare parts.
- Inspection sheet.
- CE conformity certificate.

2.1. GENERAL DESCRIPTION

The machine is used in civil and industrial areas for sweeping, washing and drying flat, horizontal, smooth and moderately rough floors, with even surfaces free from obstacles. When used with the Combi accessory, areas inaccessible to the machine may be washed and dried.

The power supply with storage batteries and the high capacity of the batteries that may be used allow **maximum freedom of movement** and independent work time **to suit all working conditions**.

A large tank, a high-power scrubbing and sweeping head, a powerful drive motor allow maximum efficiency and effective washing to be combined with extreme simplicity of use.

With the electronically-controlled drive and forward and reverse gears, any path may be easily followed on the floor to be cleaned.

2.2. PRINCIPAL PARTS AND WORK CYCLES (fig. 1)

- A - Group of batteries.
Supplies energy for feeding the machine.
- B - Tank unit.
Contains the mixture of clean water and detergent and collects the dirty water lifted from the floor.
- C - Controls.
- D - Chassis.
- E - Squeegee suction unit.
Collects and lifts the water, drying the floor.
- F - Scrubbing and sweeping head unit.
Distributes the detergent solution on the floor, removing the dirt and collecting refuse.
- G - Drive unit.
This is composed of an electronically controlled geared motor which allows the machine to move backwards and forwards.
- H - Head controls units.
Consists of a lever for lowering and lifting the scrubbing and sweeping head unit and a lever for the regulation of the head's pressure on the floor.

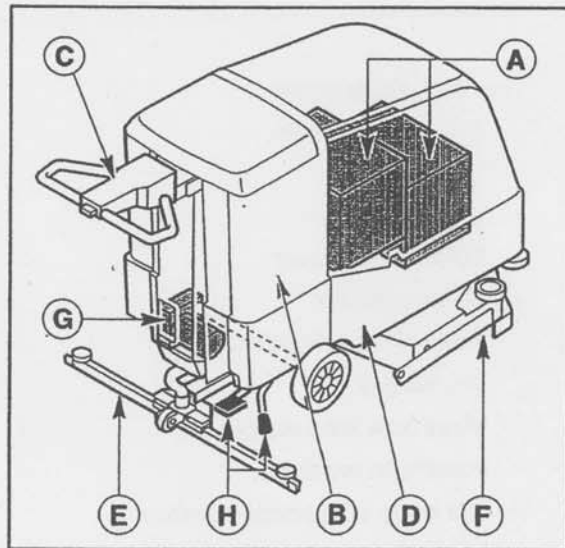

Operating cycle (fig. 2)

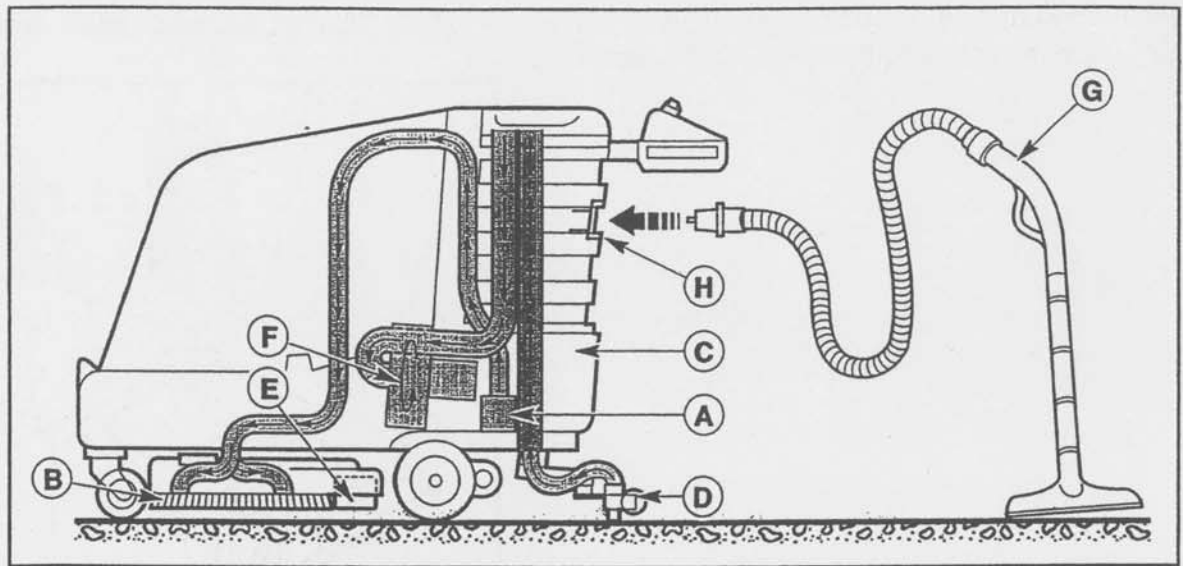

By means of the pump **A**, the machine sends a suitably dosed solution of water and detergent to the brushes **B**, from the tank **C**.

The rotation of the brushes distributes the solution, removes the dirt and lifts the refuse, depositing it in the collection box **E**.

After scrubbing, the floor is dried automatically by the squeegee **D**, using a suction system that sends the dirty water to the tank **C**.

A centrifugal compressor **F** (henceforward to be referred to as the suction device) sucks up the air from the tank **C**, creating a vacuum. The squeegee **D** is connected to the tank; it scrapes the dirty water up off the floor and collects it, allowing it to be sucked up into the tank. The ability to sweep, the possibility of fitting brushes with different material fibres (or even abrasive discs on models with disc brushes), together with an accurate choice of detergent, allow the machine to adapt to the most varied combinations of floor and dirt.

Accessory Combi **G** (optional), to insert in the corresponding socket **H** (off-the-shelf), allows the machine to wash in inaccessible positions such as corners, stairs, cluttered floor areas.

The accessory recycling sack **A** (Optional) allows to extend work autonomy and to reduce the consumption of detergent recovering, with an opportune filtering, the water intake from the floor and sending it again to the brushes.

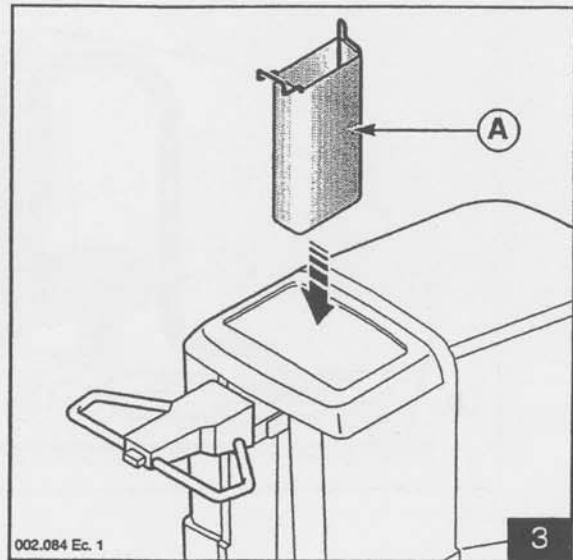

2.3. TECHNICAL SPECIFICATIONS

| | | |
|---|---------------------|---|
| General control | | electromechanical |
| Adjustable vertical force on the head | daN (kg) | 22-63 |
| Suction motor rated power | W/HP | 475/0.63 |
| Max. suction vacuum | mm H ₂ O | 1700 |
| Drive motor rated power | W/HP | 150/0.20 |
| Advance rated speed | km/h | 3.7 (max.4.5) |
| Drive control | | electronic with continuous speed variation (forward and reverse gear) |
| Detergent solution pump rated power | W/HP | 25/0.033 |
| Water pump max. flow rate | l/min | 21 |
| Diaphragm tank capacity | l | 100 |
| Max. temperature water and detergent solution | °C | 50 |
| Drive wheels diameter | mm | 200 |
| Sound pressure level | dB (a) | 69 |
| Acceleration for the upper limbs | m/s ² | <2.5 |
| Dry weight without batteries (body only) | kg | 131 |
| Usable batteries minimum capacity | Ah (5) | 175 |
| | Ah (20) | 240 |
| Usable batteries minimum capacity | Ah (5) | 260 |
| | Ah (20) | 355 |
| Usable batteries maximum capacity | kg | 4x46 |
| 6V battery max. dimensions (LxWxH) | mm | 246x198x365 |
| 12V battery compartment max. dimensions (LxWxH) | mm | 254x408x365 |
| Clean track maximum width | mm | 710 |
| Swinging squeegee width | mm | 940 |
| Hourly performance | m ² /h | 3195 |
| Working environment temperature (min-max) | °C | 4-35 |
| Number of brushes | | 2 |
| Rated diameter brush | mm | 340 |
| Diameter of abrasive discs | mm/inch | 355/14" |
| Brush rotation speed | g/min | 340 |
| Number of washing head motors | | 1 |
| Washing head motor rated power | W/HP | 1500/2 |
| Dirt collection basket capacity | l | 2.5 |
| Head weight | kg | 30 |
| Squeegee weight | kg | 4 |
| Length, width, height | mm | 1570x740x1060 |
| Weight with packing and pallet | kg | 165 |
| Dimensions of packing with pallet (LxWxH) | mm | 1490x835x1200 |

2.4. DIMENSION (fig. 6)

| | |
|------|-----|
| Head | B |
| | 740 |

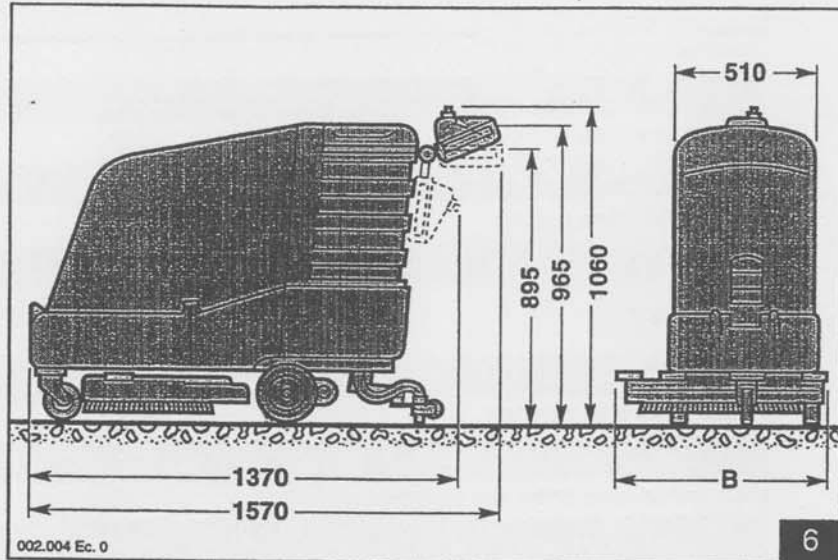

2.5. DETERGENTS - ADVICE FOR USE

The machine has been designed for use with specific detergents for floor sweeping and scrubbing machines.

Use only non foam-producing and biodegradable detergents, suitable for the type of floor and the dirt to be removed.

Follow the safety standards related to detergent use indicated in paragraph 3.1.



WARNING

Always dilute the detergents according to the manufacturer's instructions. Do not use sodium hypochloride (bleach) or other oxidizing agents, especially in high concentrations, and do not use solvents or hydrocarbons. The water and the detergent must be at temperatures no higher than the maximum value indicated in the technical data and they must be free from sand and/or other impurities.



WARNING

If you use particularly powerful detergent, pour first the water into the tank and thereafter the detergent in order to avoid damages in the pump or the diaphragm.

2.6. SAFETY DEVICES (fig. 7)

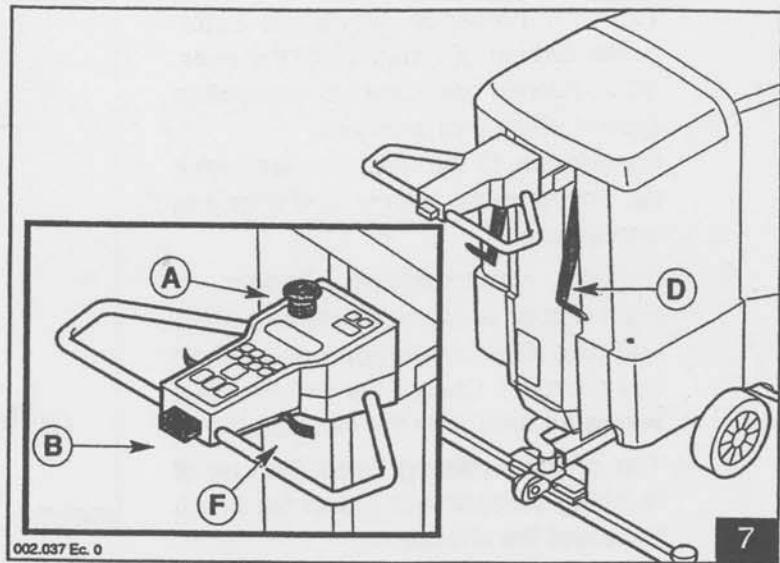

| | Device | Activation | Function |
|---|---------------------|---|---|
| A | Emergency button | Activated when pressed | Interrupts power supply. |
| B | Change of direction | Safety device to avoid crushing in reverse gear. | Inverts the direction of movement of the machine in reverse gear. |
| F | Service brake | Engages automatically when the drive lever F is released. | The machine slows down gradually ⁽¹⁾ . |
| D | Parking brake | Engages when the lever D is raised. To be pulled only when the machine is standing still; it may cause damage if pulled when the machine is moving. | Prevents movement of the machine. |

(1) To increase the braking intensity, pull the drive lever in the direction opposite that in which the machine is moving.

2.7. DANGER ZONES (fig. 8)

- A - Tank.** In presence of certain detergents, danger of irritation for the eyes, skin, mucous membranes, respiratory system, danger of asphyxia.
Danger due to the dirt recovered from the environment (germs and chemical substances).
- B - Battery compartment.** Danger of short circuits between the battery poles and presence of hydrogen during battery charging. Charge the batteries in a ventilated area, with the hood open.
- C - Top of the washing head.** Danger of crushing between the top of the brush head and the chassis.
- D - Dirt collecting basket compartment.**
The brushes are accessible when the basket is not in position.
- E - Bottom of the washing head.**
Danger when lowering the head and brush rotation.

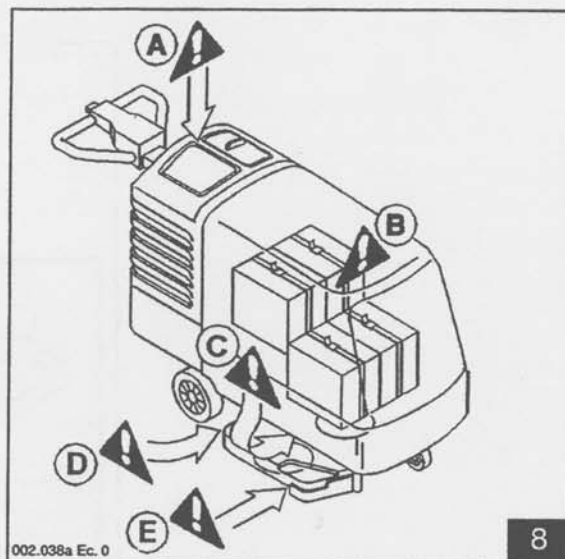

2.8. OPTIONAL UNITS

Recycling unit:

allows prolonged work time and reduction of detergent consumption by recovering the water taken up from the floor, by means of a suitable filtering system, and sending it back to the brushes.

Combi Set:

a quick coupling is fitted on the machine in the factory to allow the use of an accessory for washing and drying where the machine cannot do the job itself (stairs, under-stair area, inaccessible corners, etc).

2.9. ACCESSORIES

- Bristle brushes.
Used for washing delicate floors and for polishing.
- Polipropilene brushes.
Used for normal floor washing.
- Tynex brushes.
Used for accumulated stubborn dirt on resistant floors.
- Drive discs.
Allow the use of the discs described below:
 - Yellow discs.
Used for washing and polishing marble and similar surfaces.
 - Green discs.
Used for washing resistant floors.
 - Black discs.
Used for thorough washing of resistant floors, with stubborn dirt.
- Combi Set.
- Carpet head for Combi Set.
- Strip head for Combi Set.
- Sucker head for Combi Set.
- Recycling filter sack.

3

SAFETY INFORMATION

3.1. SAFETY STANDARDS



Read the instructions manual carefully before proceeding with the start-up operations, use, maintenance, routine maintenance or any other jobs on the machine.



WARNING

Scrupulously respect all the advice given in the manual (especially those concerning danger and special attention), and the safety plates applied directly on the machine. The Manufacturer declines all responsibility for damage to persons or things resulting from failure to respect the safety indications.

The machine may only be used by trained personnel that has demonstrated its own capacity and that has been explicitly assigned to the use of it. Use of the machine is forbidden for minors.

Do not use this machine for purposes other than those for which it is intended. Consider the type of building that you are working in (e.g. pharmaceutical, chemical industries, etc.) and scrupulously respect the standards and safety conditions in force there.

Do not use this machine in places inadequately illuminated, explosive environment, public roads, in the presence of noxious dirt and in insanitary environments.

Do not inhale flammable or explosive liquids (ex.gasoline, combustible oil, etc) flammable gas, dry dust, acids and solvents (ex. thinner, acetone, etc) even if diluted. Do not inhale steam from burning or boiling objects.

Do not use the machine on slopes with a gradient of more than 2%. When transporting the machine or ramps or higher slopes, use the maximum care to avoid overturning and uncontrolled acceleration. Never park the machine on a slope.

Do not leave the machine unguarded when the engine is on. Leave the machine only after you have swithced off the engine, insured the machine against accidental movements, pulled the hand break and pulled out the ignition key.

Do not use the machine to transport things. Do not use it as a trailer.

Never lean weights on the machine for any reason.

Never block the ventilation and heat dispersion openings.

Do not remove, modify or avoid the safety devices.

Many unpleasant experiences have shown that various parts of people's clothing may cause severe accidents: before starting work, remove any jewelry, watches, ties or other accessories.

Always use the individual protections for operator safety: protective overalls or apron, no-slip waterproof shoes, rubber gloves, protective eyeglasses and a mask to protect the respiratory organs.

Do not put your hands close to the moving parts.

Do not use detergent different from the recommended ones and follow their related safety instructions.

We recommend you to keep detergents out of reach of children and in case of contact with the eyes rinse immediately with water and in case of consumption contact immediately a doctor.

It is indispensable to observe the battery manufacturer's instructions and observe the directions of the legislation.

Always keep the batteries clean and dry in order to avoid superficial dispersion of currents. Protect the batteries from impurity, for example metal dust. Do not lean tools against the batteries, danger of short circuit and explosion.

Be attentive when using battery acid. Observe the related safety instructions.

In the presence of particularly high magnetic fields, consider their possible effect on the control electronics.

In the event of breakdown and/or bad operation of the machine, switch it off immediately (disconnecting it from the power mains or from the batteries) and do not tamper with it. Contact one of the Manufacturer's technical service centres.

All operations on the electrical system and all maintenance and repair jobs not explicitly described in this manual must be performed by specialized technical personnel, experts in the sector.

Only accessories and spare parts sold by the manufacturer are allowed since only these can assure that the machine works safely and without inconvenience. Do not use parts taken from other machines.

This machine has been projected and constructed for a service length of the years from the date of manufacture stamped on the data plate. At the end of this period the machine has to be destroyed or go through a complete revision by the manufacturer.

If it is decided not to use the machine any longer we recommend you to take out the batteries and leave them for recycling. We also recommend you to empty the tank and to destroy the parts that can be of danger, for example for children that could use a machine that is not in use as a toy.

4

HANDLING AND INSTALLATION

4.1. PACKING (fig. 1)

The machine body is packed and fixed onto a wooden pallet with anchoring brackets; it is covered with a cardboard box closed with strapping.

The head and the squeegees are packed in cardboard boxes without a pallet.

4.2. LIFTING AND TRANSPORT (fig. 1)

When packed the machine body may be lifted only with a fork lift truck. The heads may also be lifted by hand.

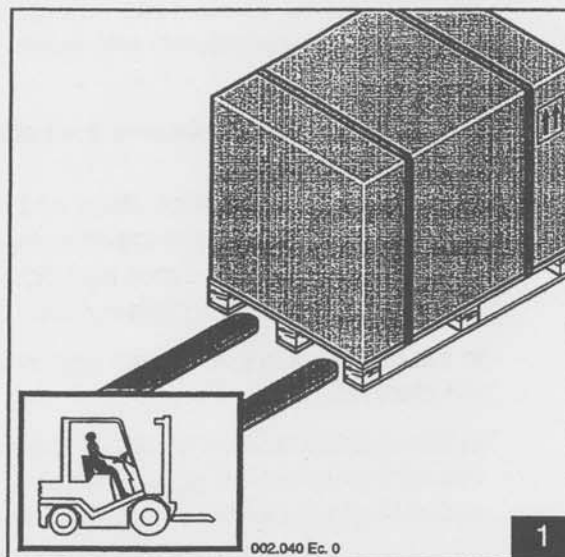

INFORMATION

Handle with care, avoiding jolts, and without overturning.

4.3. UNPACKING AND CLEANING

On delivery, check that the machine is unbroken. If you find it has suffered any damage, report this to the carrier and accept the goods only with your written reserve to present a claim for the refund of damage.

- Cut the strapping **A** (fig. 2).
- Remove the cardboard **B** (fig. 2).
- Open the hood **C** (fig. 3) and take out from the pocket **E** (fig. 3) the instructions manual, the inspection sheet, the guarantee card, and the cards with serial number for ordering spare parts.
- Take out the envelope **D** (fig. 3) placed inside the battery compartment.
- Check the contents of the envelope:
 - 2 knobs for fixing the handle;
 - 1 battery cable;
 - 2 bridges with short clamps;
 - 1 bridge with long clamps;
 - 1 connector for the battery charger;

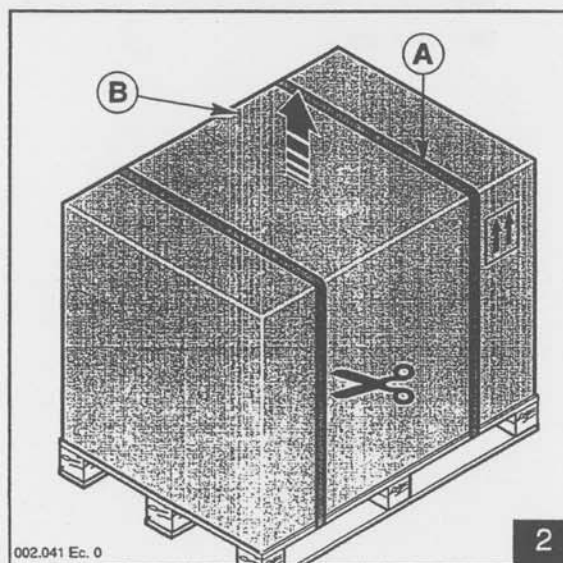

- Two copies of the ignition key.

i INFORMATION

Put one of the two keys in a safe place so that it can be located in case the other one is lost; the other key is to be inserted in the lock on the mushroom switch.

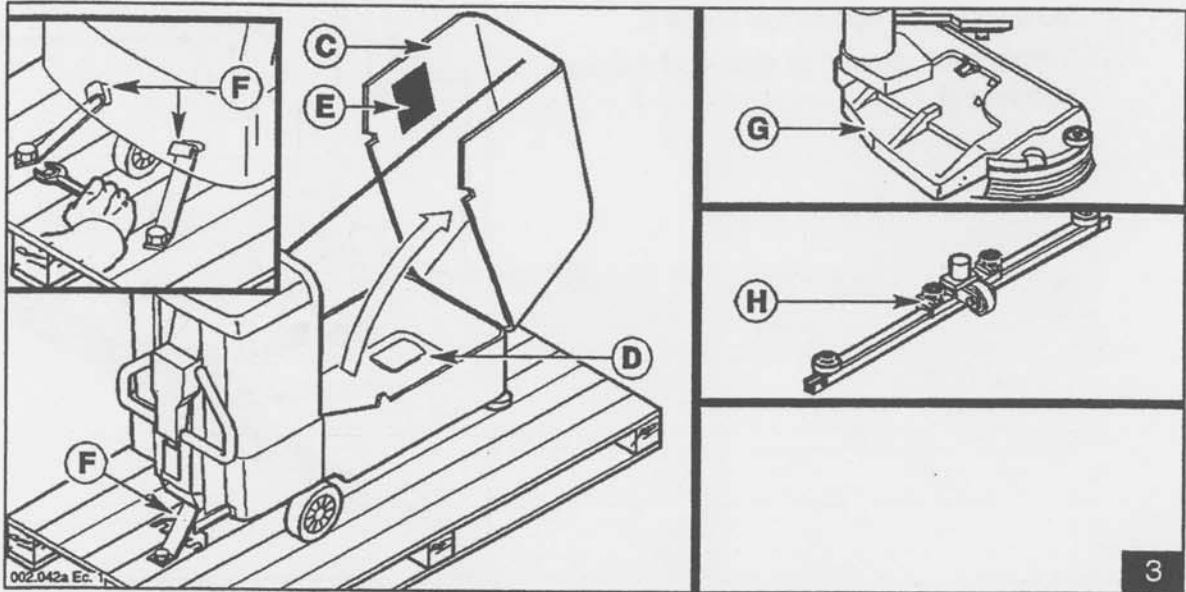

- Unscrew the bolts and remove the brackets F (fig. 3).
- Free the head G, the brushes, the squeegee H from their packing.
- Have the head fitted by an authorized service centre.
- Clean the outside of the machine, following the instructions in § 7.2.1.
- Eliminate the packing material, using containers for separate refuse collection.

4.5. HANDLE - INSTALLATION (fig. 4)

- Lift the handle A and block it with the knobs B supplied in the envelope.

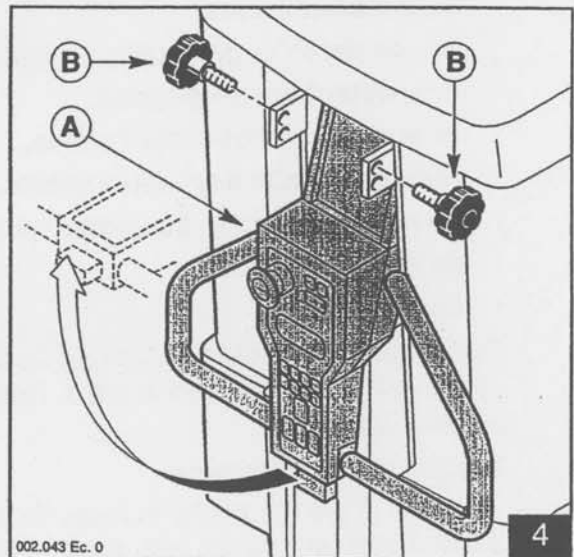

4.6. SQUEEGEE - INSTALLATION

(fig. 5)

- Lift the squeegee support **A**, lowering the lever **B**.
- Slacken the knobs **C**.
- Insert the squeegee **D** in the slots in the support **A** and tighten the knobs **C**.
- Firmly push down the sleeve of the suction tube **E**.

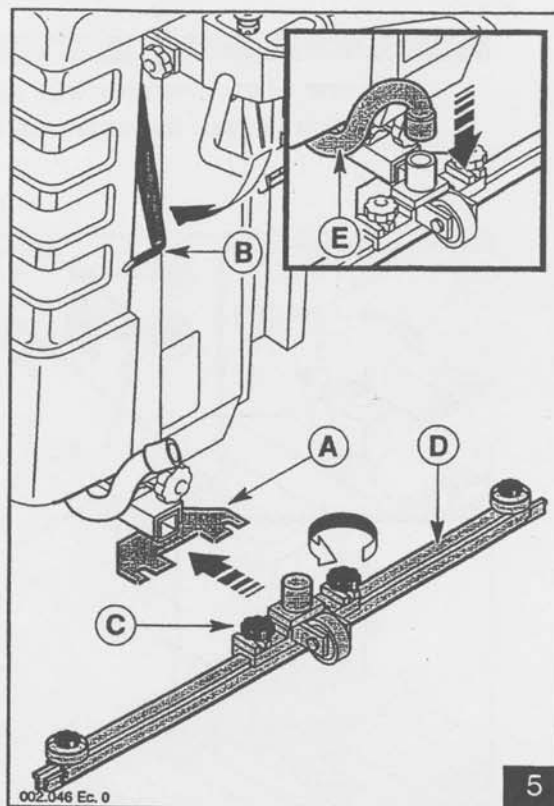

4.7. FEEDING BATTERIES



DANGER

During any kind of battery maintenance follow the related safety instructions for batteries indicated in paragraph 3.1. Besides that:

- wear rubber gloves.
- use an apron or protective overalls.
- use protective eye-glasses.
- wear non-slip waterproof shoes.
- keep away from any naked flames.
- do not short-circuit the battery poles.
- do not cause sparks.
- do not smoke.

Two different types of batteries may be fitted on this machine; their characteristics must correspond with those indicated in § 2.3. They must be kept charged, dry and clean, with their connections tight.

Tubular armored batteries.

The level of the electrolyte in these batteries must be checked periodically.

When necessary, top up with distilled water alone until the plates are covered; do not overfill (max. 5 mm above the plates).

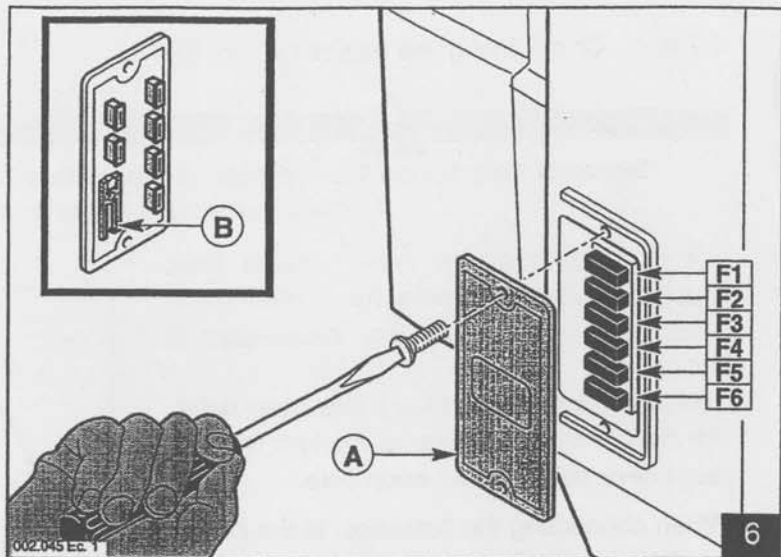

Gel batteries

These require no maintenance.

When using this type of battery, a 5A fuse (F1 fig. 6) must be fitted in the base, using the tweezers B (fig. 6). This informs the electronics what type of battery is used.



WARNING

Do not fit the fuse F1 if gel batteries are not being used.

4.7.1 Batteries - Use

When supplied the batteries are normally filled with acid and ready for use. However, before starting the machine it is advisable to recharge them.

Proceed as indicated, see "Batteries - Recharging procedure" (§ 4.8.2).

4.7.2 Batteries - Installation (fig. 7)

- Remove the hood A and lay it on the floor, next to the machine.
- After opening the clips on the belts B insert the batteries C, placing them in the direction indicated in the figure and on the label D inside the hood A.
- Tighten the straps B to block the batteries.

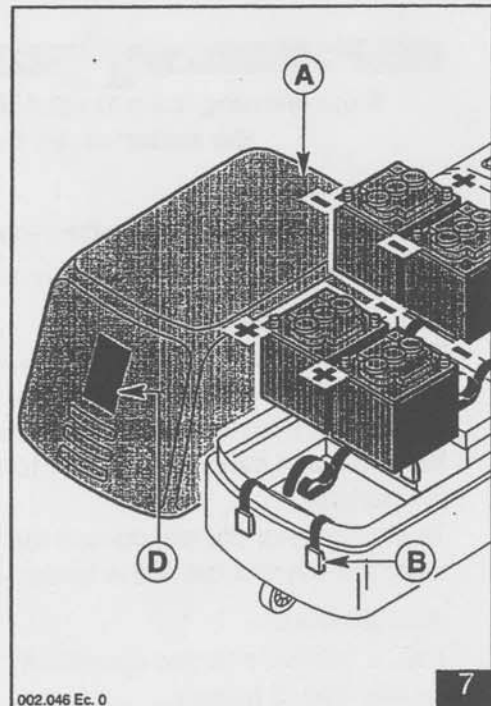

WARNING

When lifting the batteries, remember that they weigh up to 46 kg each.

4.7.3 Connecting the batteries (fig. 8)



DANGER

Scrupulously follow the indications described below, as short-circuit of the battery may cause them to explode.

Before fitting a clamp finally onto a pole, touch it against the pole for a moment. If there are any sparks the connection is wrong.

The positive and negative poles have different diameters; fit the clamp marked with the respective polarity onto each pole.

When connecting the batteries, fit the cables as shown in the figure.

- Tighten the bolts on the clamps and cover them with grease.
- Check that the box F is firmly in place.
- Connect the connector E to the one on the machine D.

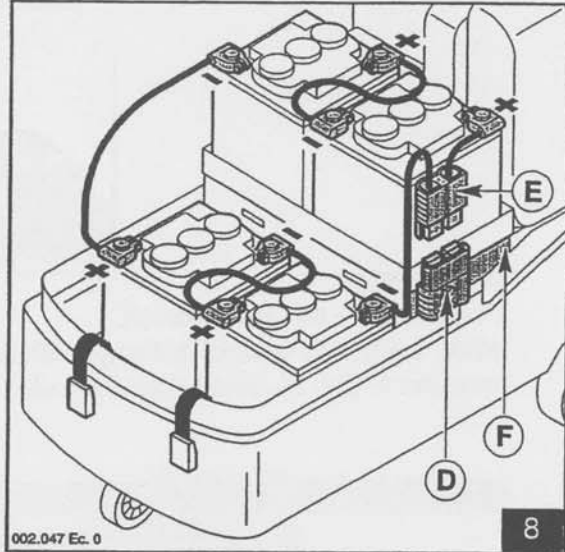

4.8. RECHARGING THE BATTERIES



WARNING

If the warning lamp D (S6.1, fig. 1) is flashing proceed immediately to recharge the batteries, so that they will not be irreparably damaged.

4.8.1 Choosing the battery-charger

Check that the battery-charger is compatible with the batteries to be charged:

Tubular lead batteries.

The battery-charger must have a maximum initial current of 16 A (with the DIN Wa method) or from 20 to 50 A (with the DIN Wo Wa two-stage method) for each 100 Ah (5) of the battery.

To confirm your choice, consult the Manufacturer and the manual of the battery-charger.

Gel batteries.

Use a battery-charger specifically intended for this type of battery.

Installing the battery-charger (fig. 9)

Following the instructions enclosed with the connector B:

- remove about 13 mm of sheath from the black and the red cable C;

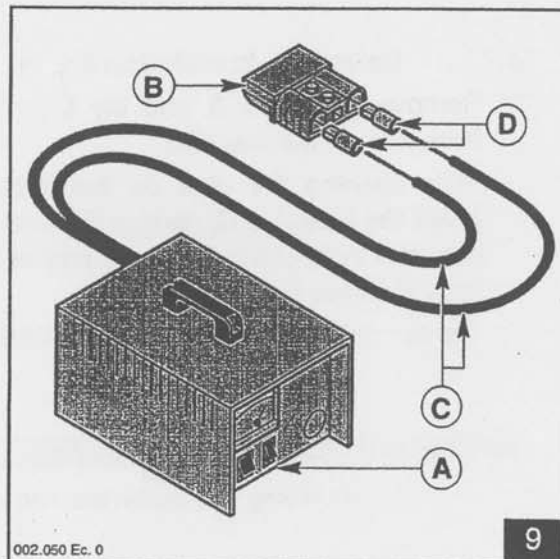

- clip the connector terminals **D** onto the cables **C**;
- Insert the terminals in the connector **B**, respecting the polarity: red cable +, black cable-.

**DANGER**

Incorrect connection of the battery-charger may cause severe damage to the batteries and, in some cases, may even cause them to explode.

4.8.2 Batteries - Recharging procedure

- Open the hood **A**.
- Disconnect the connector **E** from **D**.

Lead batteries with liquid electrolyte (fig. 10)

**WARNING**

Perform the operations described below only after having taken the machine into a ventilated environment, far from fires, sparks, lit cigarettes ...

- Remove the caps **C** and check the electrolyte level, topping up with distilled water if necessary.
- Connect the connector **E** to the connector **B** on the battery-charger.
- Recharge following the indications in the manual of the battery-charger.

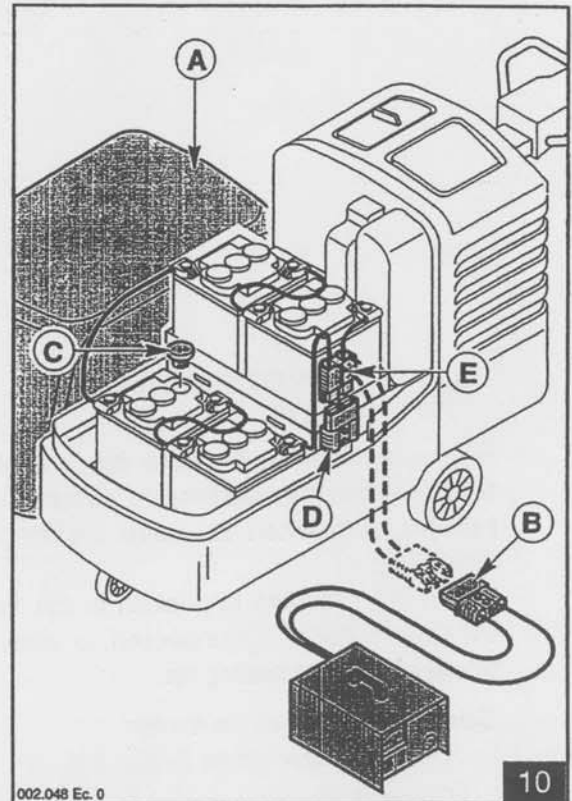
**WARNING**

Do not let the temperature of the electrolyte exceed 45° during recharging.

- At the end of the recharging time, check the intensity with a densimeter. If one or more elements is flat and the remaining ones are completely charged, the battery is damaged and must be replaced.

- Check the electrolyte level and top up with distilled water if necessary; close the cap **C**.
- Connect the connector **E** to the one on the machine **D**.

Gel batteries (fig. 11)

- Connect the connector **E** to the connector **B** on the battery-charger.
- Recharge following the indications supplied with the battery-charger.
- At the end of the recharging time, disconnect the connector **E** and reconnect it to the one on the machine **D**.

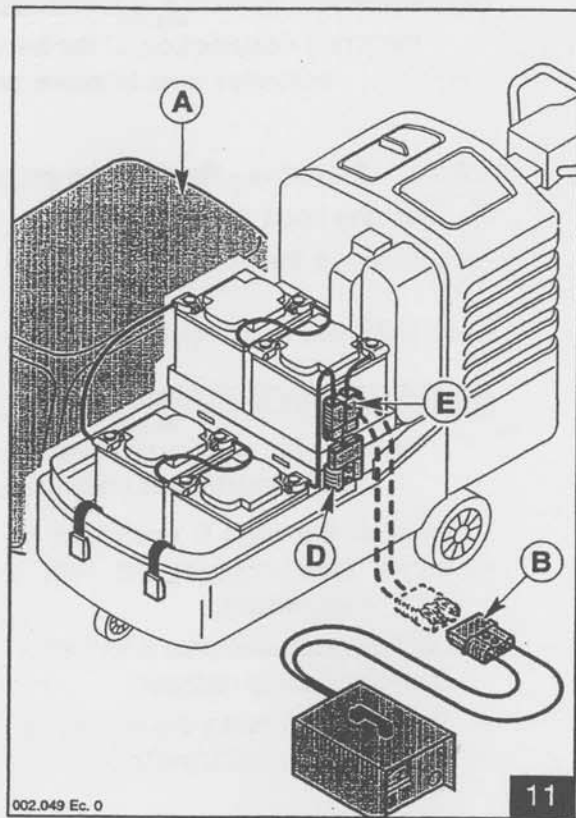

4.9. CONNECTING THE DRIVE MOTOR

For safety reasons the drive motor is always braked when the machine is switched on or not live, and when the drive system is not operating.

When the machine is packed in the factory, the drive motor is disconnected, to allow easy transport before setting up.

Connecting the drive motor.

- Open the fuse cover **B** (fig. 12).
- Connect the connectors **A**.
- Close the fuse cover.

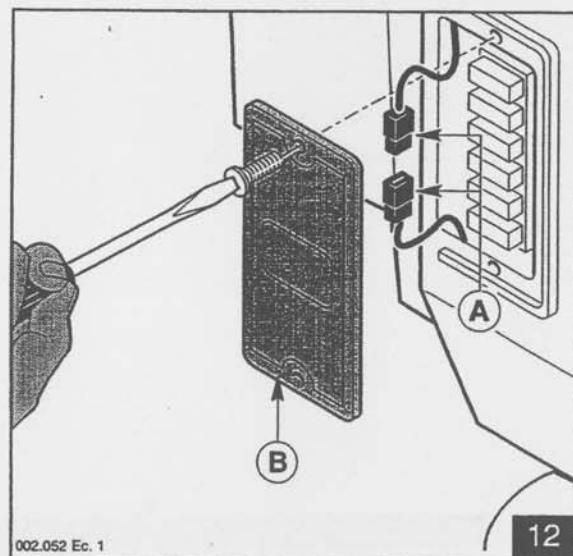

WARNING

Always engage the parking brake when the machine is left unguarded.

4.10. MANUAL LIFTING AND HANDLING

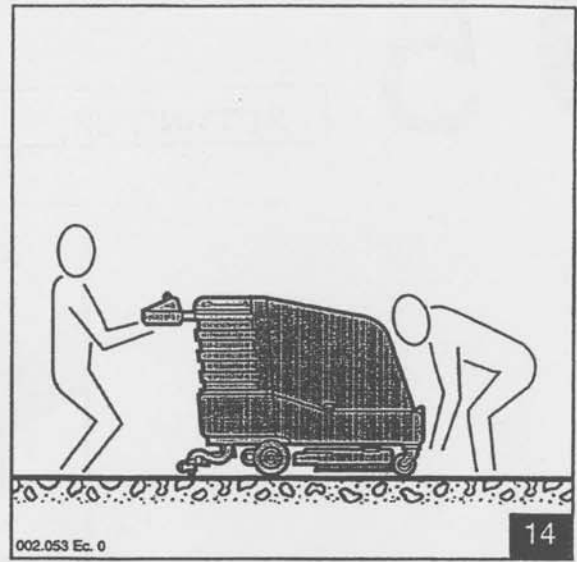
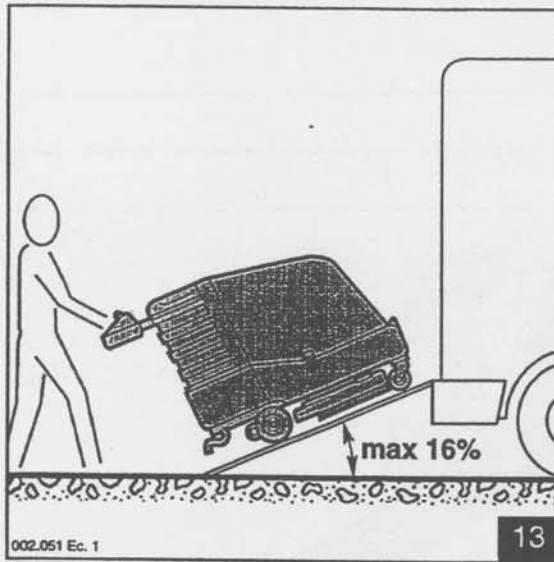

WARNING

The machine weighs about 125 + 130 kg.

There are two possible ways of loading the machine onto a vehicle:

- by using a ramp (fig. 13), after having removed the squeegee;
- manually, lifting it with two people, (fig. 14) after having:
 - removed the batteries;
 - emptied the tank and the dirt collecting box.

4.10.1 Anchoring the machine to the vehicle

- Engage the parking brake.
- Anchor the machine to the vehicles with ropes connected to the handle or to the front bumper.
- Loading and unloading of the machine from the vehicle must be carried out in a suitably lit environment.

5

SETTING UP

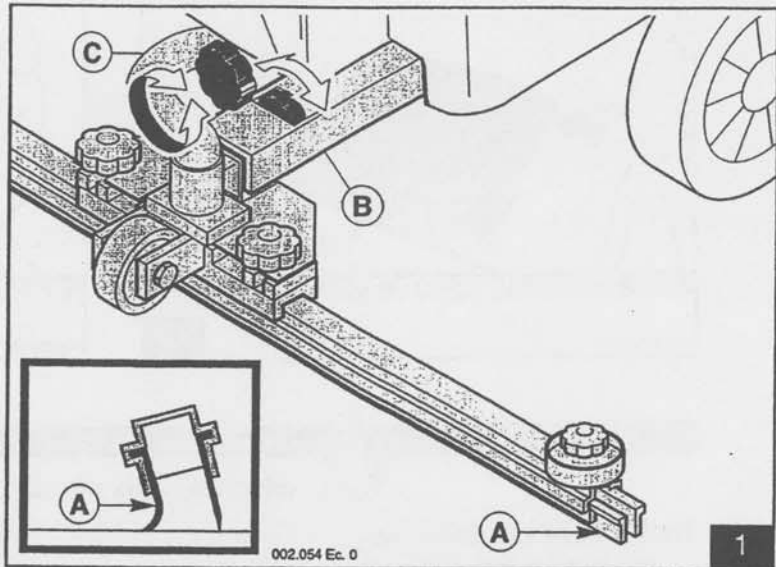

5.1. SQUEEGEE - ADJUSTMENT (fig. 1)

To obtain perfect drying, the squeegee must be adjusted in such a way that the lip of the rear blade **A** bends by about 45° during operation.

B - Angle adjusting knob.

C - Pressure adjusting knob: turn clockwise to raise the pressure, turn counter-clockwise to lower the pressure.

5.2. HANDLE - ADJUSTMENT (fig. 2)

The handle may be adjusted in two positions.

- Unscrew the knobs **A**.
- Lower or lift the handle **B**.
- Tighten the knobs **A**.

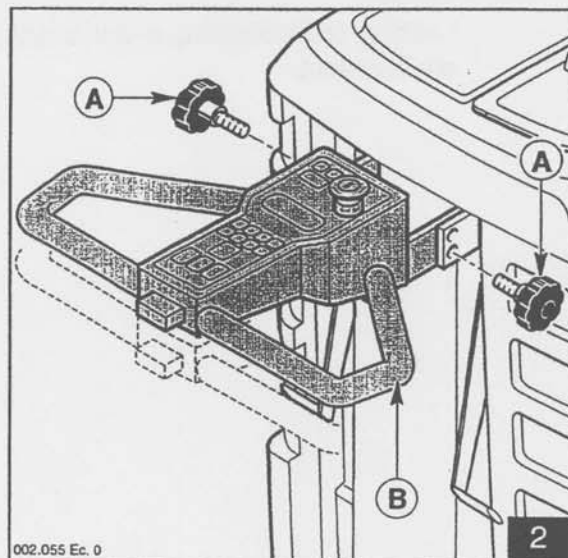

5.3. DRAINING OFF DIRTY WATER (fig. 3)

**WARNING**

The fluids recovered contain detergents, disinfectants, water, organic and inorganic material recovered during operation; they must be disposed of according to the laws in force in the areas concerned.

**DANGER**

Use the individual protection devices listed in § 5.7.

- Take the machine next to a drain.
- Detach the drain hose A from its seat and position the cock B over the drain.
- Remove the stopper from the cock B by twisting it.
- Once all the contents of the tank have been drained off, put back the stopper and put the hose back in position.
- For complete cleaning, before closing the cock B remove the cover of the tank C and wash the inside.

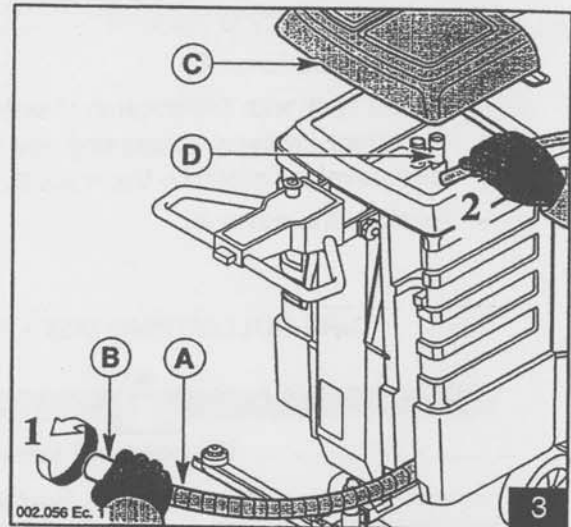
**WARNING**

During washing, do not let water get into the nozzle D because it is connected to the suction motor.

5.4. DRAINING AND FILLING WITH WATER AND DETERGENT SOLUTION

**DANGER**

Use the individual protection devices listed in § 5.7.

Drainage (fig. 4)

- Go to the area in which you want to empty the liquid.
- Remove the cover A.
- Detach the hose B and position it over the drain.
- Switch on the machine and press "1" on the Combi accessory switch X (§ 6.1. fig. 1). Once all the liquid has been drained off, press "0" on the Combi accessory switch X (§ 6.1. fig. 1)..

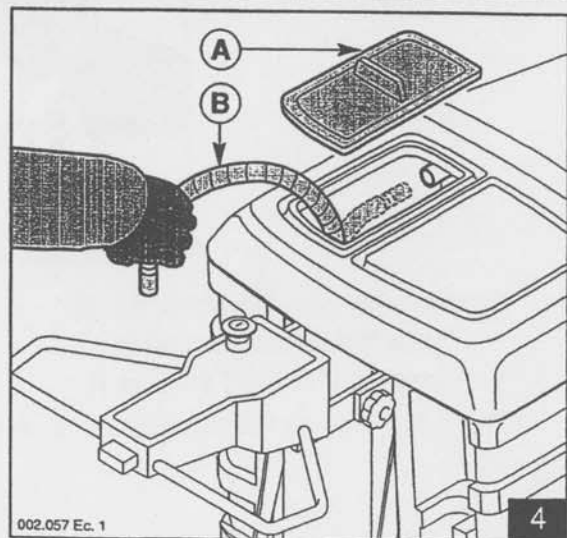

- Put the hose **B** back in position and put back the cover **A**.
- The water and detergent solution may also be used for washing the dirty water tank.

Filling (fig. 5)

To fill the diaphragm tank:

- Remove the cover **A** and the cover **C**.
- Check that the recovery tank is empty; if it is not, empty it (§ 5.3.).
- Enlarge the diaphragm sack if it does not adhere properly to the tank.
- Replace the cover **C**.
- Fill the sack with the solution of water and detergent, without exceeding the maximum level indicated by the mark **D**.
- Replace the cover **A**.

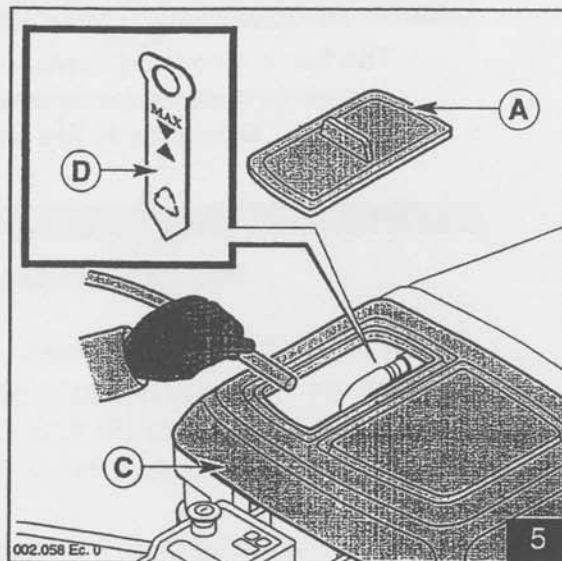
**5.5. DIRT COLLECTING BOX - REMOVING AND FITTING****WARNING**

Do not work unless the box is perfectly installed.

Before removing the box, stop the machine, wait until the head has come all the way up (bring the head up with the pedal) and the brushes have stopped; then press the emergency button.

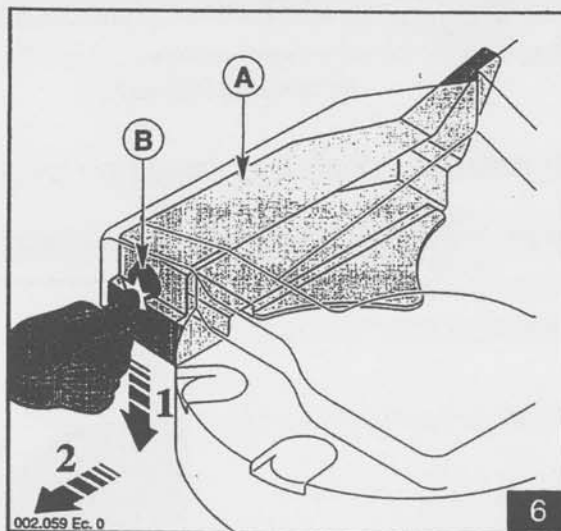
**Heads with disc brushes (fig. 6).**

- Press the release button **B**.
- Lower and remove the box **A**.

To fit the box, repeat the operations described for removal in inverse order.

5.6. BRUSHES - INSTALLATION



WARNING

Do not work unless the brushes are perfectly in place.

Before removing the brushes, switch off the machine, wait until the head has come all the way up and the brushes have stopped; then press the emergency button and disconnect the battery connector **A** (fig. 7).

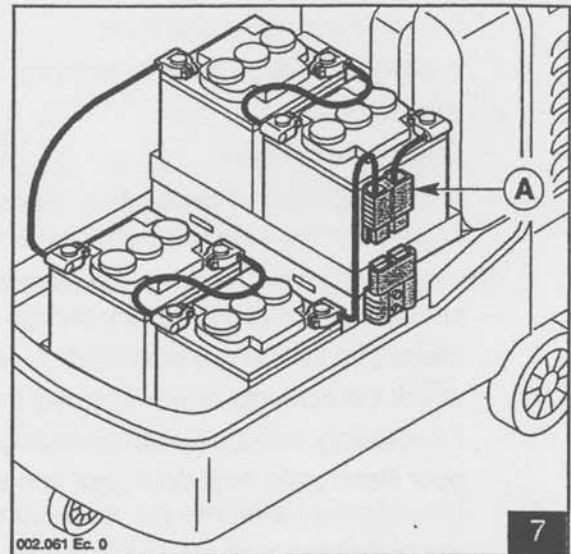
**Removing (fig. 8)**

- Press the top edge of the brush **B** down with both hands, through the slots provided.

Fitting (fig. 8)

- Grip the brush **B** at the sides with both hands.
- Centre the hexagonal socket on the brush with the outline of the brush cover.
- Press upward and turn gently until the brush makes connection.
- To use the abrasive disc, preassemble the drive disc and then fit it on the machine.

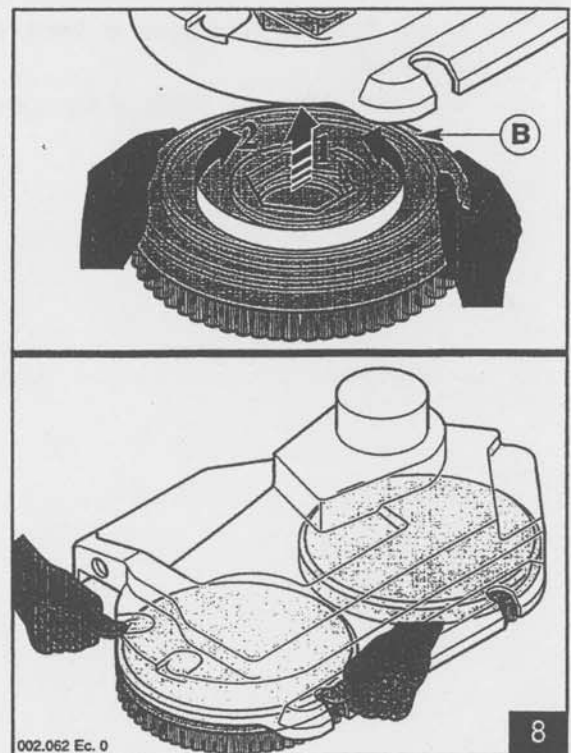

5.7. PREPARING THE MACHINE FOR WORK

**DANGER**

During machine preparation, wear:

- non-slip waterproof shoes;
- a mask to protect your breathing;
- overalls;
- waterproof gloves;
- **any other form of protection recommended by the supplier of the detergent or necessary for the environment you are working in.**

Before starting work, perform the following operations:

- check the level of the battery charge and recharge if necessary;
- check that the battery connector is connected;
- check the contents of the recovery tank and empty it if necessary;
- if necessary, empty the dirt collecting box;
- pour clean water and detergent in a suitable concentration into the detergent solution sack (do not pour water into the recovery tank);
- check that the tank cover and the detergent solution cover are perfectly closed (imperfect closing may considerably reduce the machine's drying power);
- fit brushes, drive discs of a suitable type for the floor and the job to be done;
- check that the squeegee is firmly fixed, connected to the suction hose and correctly adjusted;
- ensure that the rear blade of the squeegee is not worn.

6

USE

6.1. DESCRIPTION OF THE CONTROLS (fig. 1)

– Control panel.

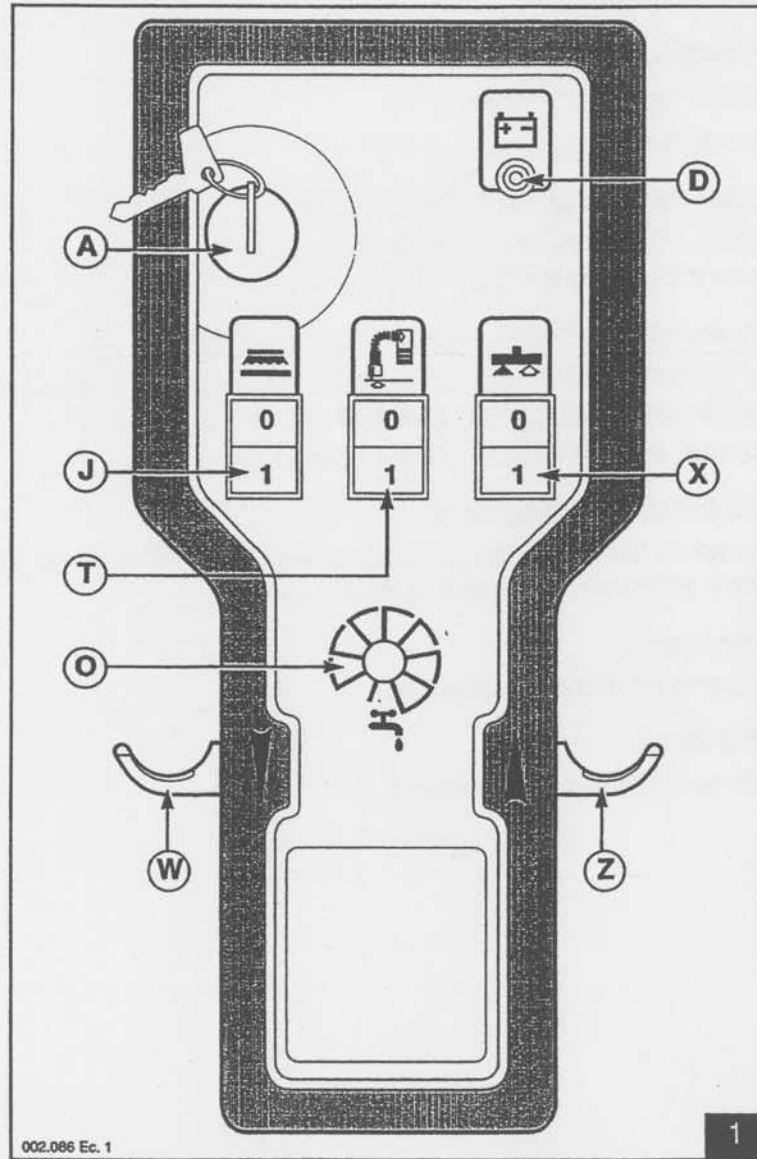

A - Main switch - emergency button with key

Switches on and off the electric power supply to the machine.

- Press the button to stop the machine. Use the ignition key to restart the machine.

D - Warning light (red).

Shows that the power supply is activated and indicates the level of the battery charge:

off: the machine is off;

flashing at a steady frequency: the machine is on but the batteries are almost flat and must be recharged immediately because they may be irreparably damaged if you keep working with the machine;

flashing with intervals: sequences of flashing with intervals of about 2 seconds indicate that the float is out of position and the suction device is blocked;

lit: the machine is switched on.

J - Brush switch with pilot light

– “1”: the motor turns the brushes.

– “0”: the brushes stop.

O - Detergent solution pump knob

To vary the flow of solution (clean water and detergent).

Turn clockwise to increase the flow.

X - Comby accessory function switch with pilot light

– “1”: switches on the accessory function: the brushes are stopped (if they were working), and the accessory feeding pump switched on.

– “0”: the suction unit and the pump are switched off.

T - Suction button with pilot light

Switches on and off the suction motor, which allows drying of the floor you are working on.

The pilot light is active when the suction device is fed.

W - Reverse lever

Pull it towards you for reverse movement.

Z - Forward lever

Pull it towards you for forward movement.

6.2. SQUEEGEE - USE (fig. 2)

- Lower the squeegee **A** by lifting the lever **B**;
- press "1" on the switch **T** (§ 6.1. fig. 1) to activate suction. At the end of the job, press "0" on the switch **T** (§ 6.1. fig. 1);
- lift the squeegee **A**, lowering the lever **B**.

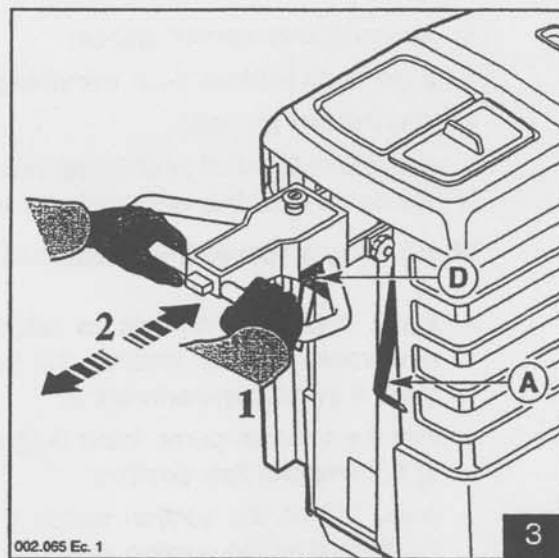
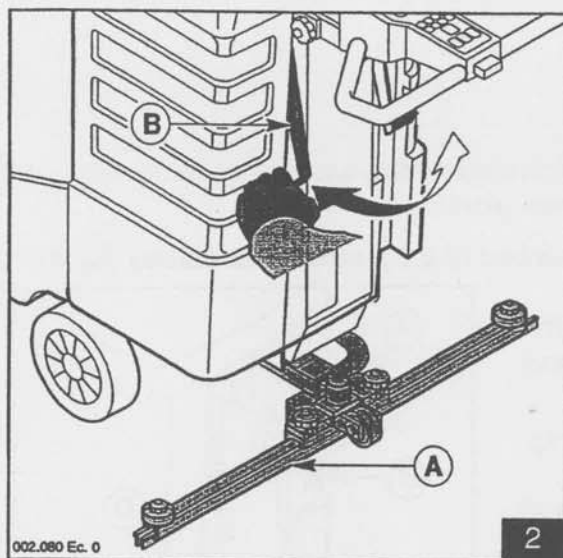
**6.3. PARKING BRAKE - USE (fig. 3)****WARNING**

Do not leave the machine unattended with the parking brake disengaged. Do not engage the parking brake when the machine is moving.

To engage the parking brake:

- ensure that the machine is standing still;
- raise the lever **A**;
- push or pull the machine to make the brake click into position and block the machine.

To disengage the parking brake:

- lower the lever **A**, moving the machine at the same time to assist release.

6.4. DRIVING THE MACHINE

- To move the machine, use the drive lever: when lever **Z** (§ 6.1.) is pulled the machine accelerates in a forward direction, while when lever **W** (§ 6.1.) is pulled it accelerates in a backward direction (reverse).
- To brake, release the drive lever: the motor acts as an electromagnetic brake, slowing down the machine with gradual braking; to accentuate braking, pull the lever opposite the direction in which the machine is moving.

6.5. PROCEDURES FOR USING THE MACHINE



DANGER

Before starting work you are advised to wear:

- overalls;
- non-slip waterproof shoes;
- a mask to protect your breathing;
- waterproof gloves;
- any other form of protection recommended by the supplier of the detergent used or necessary for the environment you are working in.

After having prepared the machine as described (§ 5.7.), proceed as follows (fig. 4):

- insert and turn the key to release the mushroom button, remove the key and place it in the compartment A;
- turn the solution pump knob O (§ 6.1. fig. 1) to minimum flow position;
- press "1" on the suction switch T (§ 6.1. fig. 1) to start the suction device;
- lower the squeegee with the lever B and, if necessary, adjust it (§ 5.1.);
- adjust the lever with three positions G to minimum pressure of the brushes on the floor;
- lower the brushes with the pedal I;

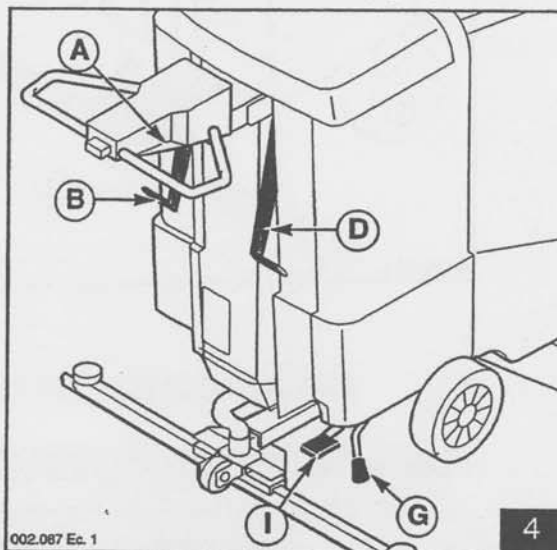

WARNING

the set pressure must be suitable for the type of floor you are working on; too high a pressure could damage the floor;

- press "1" on the brush switch J (§ 6.1. fig. 1): the brushes start to turn while the pump sends solution onto the floor;
- disengage the parking brake D, if engaged;
- pull the forward drive lever and guide the machine over the floor to be washed;
- adjust the speed with the forward lever Z (§ 6.1. fig. 1);
- while working, check the washing quality and, if necessary, regulate the flow of water and detergent solution turning the knob O (§ 6.1. fig. 1);
- if necessary, stop the machine and adjust the squeegee's pressure and angle and the brush pressure;



WARNING

never leave the machine standing still the head down and the brushes moving: you could damage the floor.

- if the red warning light **D** (§ 6.1. fig. 1) placed on the control panel starts to flash at a steady frequency: the batteries are almost flat and must be recharged immediately since there is no device that blocks the machine's functions in this case;
- if the warning light **D** (§ 6.1. fig. 2) is flashing with intervals of about 2 seconds: indicates that the float is out of position and the suction device is blocked. The recover tank must be emptied (§ 5.3.);

after finished work:

- stop the machine and apply the hand brake;
- switch of the brushes with the switch **J** (§ 6.1. fig. 1);
- lift the head from the floor with the pedal **I**;
- leave the suction motor on for at least two minutes with the tank cover open , to make sure that the suction device is dry;
- press the main switch **A** (§ 6.1. fig. 1) to switch of the power supply to the machine.



WARNING

The front wheel of the machine must touch the floor.

6.6. RECYCLING SACK ACCESSORY - USE (fig. 5)

The accessory recycling sack allows to extend work autonomy and to reduce the consumption of detergent recovering, with an opportune filtering, the water intake from the floor and sending it again to the brushes.

To install the accessory, consisting of a frame **A** and of a recycling filter sack **B**, proceed as follows:

- if the diaphragm sack is present in the tank remove the pump **A** (§ 7.2.7 fig. 7) from the sack and take out the diaphragm sack **B** (§ 7.2.7 fig. 8) from the tank;
- dress the frame **A** with the recycling sack **B**;
- tie the strings **C** to the frame **A** to fasten the sack to the frame;

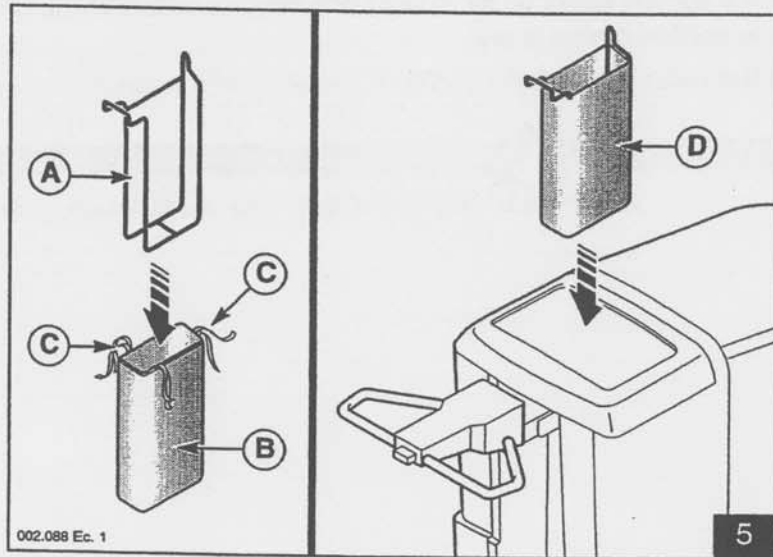

- put the frame and the sack **D** inside the tank;
- hook the frame in the adapt holds inside the tank;
- put the pump inside the filter.

6.7. COMBI ACCESSORY - USE (fig. 6)

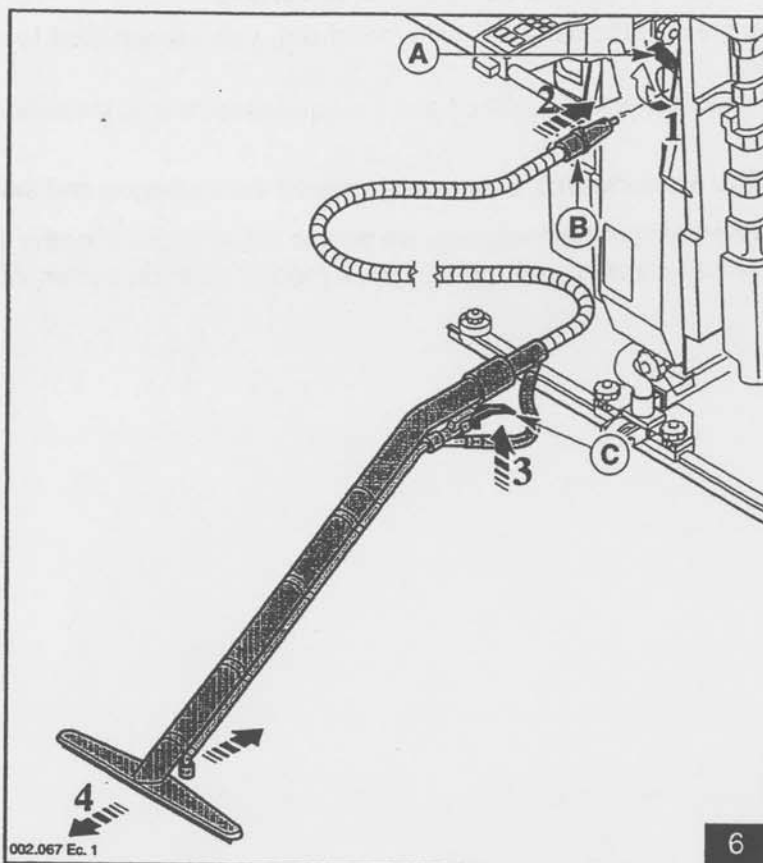

This accessory allows the machine to wash in inaccessible positions such as corners, stairs, cluttered floor areas.

To use the accessory proceed as follows:

- stop the machine and apply the parking brake;
- if the machine is on switch off the brush motor with the switch J (§ 6.1. fig. 1);
- lift the head from the floor with the pedal I (§ 6.5. fig. 4);
- lift the cover A and insert the coupling B as far as possible with the air passage hole facing upwards;
- close the cover A on the coupling B;
- ensure that the diaphragm sack for the solution of water and detergents is not empty;
- press "1" on the Combi accessory switch X (§ 6.1. fig. 1) ;
- spray on the detergent solution, pulling the lever C and rub the floor with the bristles to remove the dirt;
- suck up the dirty water, sliding the squeegee over the floor and using the part with rubber blades;
- at the end of the job, press "0" on the Comby accessory switch X (§ 6.1. fig. 1);



WARNING

Never leave the machine unattended with the pump and/or the suction unit operating.

6.8. ADVICE ON OPTIMUM USE OF THE MACHINE

If the floor presents a particularly difficult type of dirt, you are advised to wash and dry it in separate stages:

- start washing with the suction unit off and the squeegee raised, insisting particularly on the dirtiest areas;
- go over the floor a second time, after having lowered the squeegee and switched on suction.

For easy use and maximum performance, we advise following work paths that are as straight as possible, eventually finishing off quickly with a mop or cloth or, better still, with the Combi.

7

MACHINE MAINTENANCE

7.1. MAINTENANCE - GENERAL RULES

Regular maintenance, performed according to the Manufacturer's indications, guarantees better performance and longer machine life.



DANGER

Before carrying out any maintenance job, disconnect the battery connector (A) (fig. 1).

The maintenance operations on the electric system, and all those not explicitly described in this operator's manual, must be performed only by skilled technical personnel, in conformity with the safety regulations in force and with the recommendations in the maintenance manual.

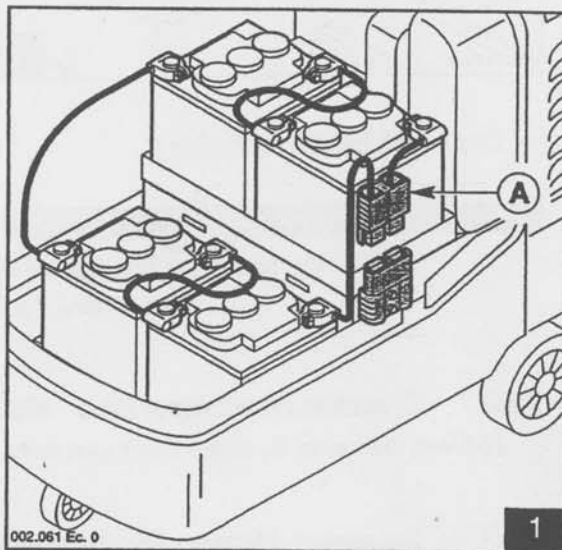

7.2. ROUTINE MAINTENANCE

7.2.1 General cleaning

Clean the machine, avoiding the use of:

- **high-pressure cleaners and jets of water**, which could cause water to get into the electric components, damaging them;
- **steam**, which could cause heat damage to the plastic parts;
- **solvents or hydrocarbons**, which could damage the hoods or the rubber parts.



INFORMATION

Do not use water on the motors or on the electric parts.

Wash periodically (§7.3.1) the diaphragm by hand with a brush with soft bristles and water and detergent. The usage of other mechanical (ex. electric brushes, cleaning machines, mechanical brushes) or chemical means (ex. solvents) may damage the sack.

7.2.2 Suction filter - cleaning (fig. 2)

- Remove the filter **A** and clean it with water or with the detergent used in the machine.

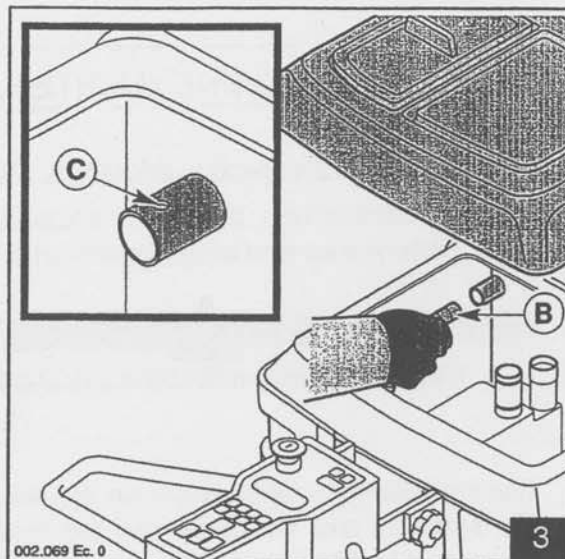
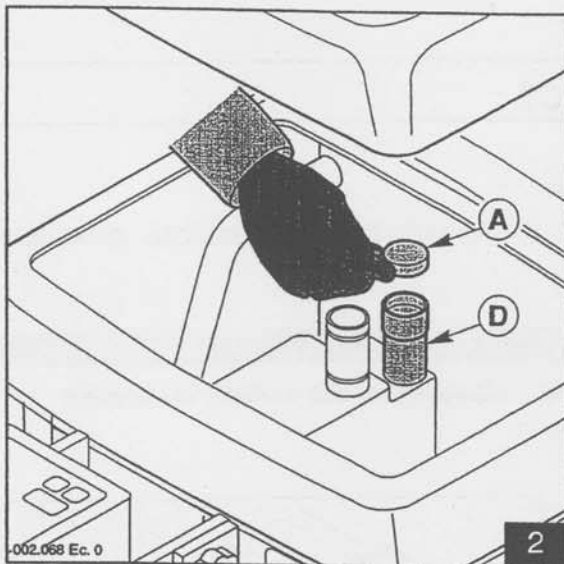

- Dry it well before replacing it.



WARNING

**Do not pour liquids or throw objects into the nozzle D:
you could damage the suction unit**

7.2.3 Cleaning liquid input hole - cleaning (fig. 3)

- Extract the hose B, clean the input hole C.

7.2.4 Squeegee blades - Replacement (fig. 4)

The squeegee is fitted with two blades, one made of rubber F (ivory coloured) and one made of polyurethane P (green).

Both blades are subject to wear and the replacement of them is performed in the following manner:

Removing the blades .

After having slackened the knobs B and disconnected the sleeve L:

- Remove the squeegee.
- Unscrew the knobs B and detach the bar C from the mouth A.
- Unscrew the knobs M and remove the wheels D.
- Remove the insert E pressing on the threads.
- Extract the two blades F and/or P.

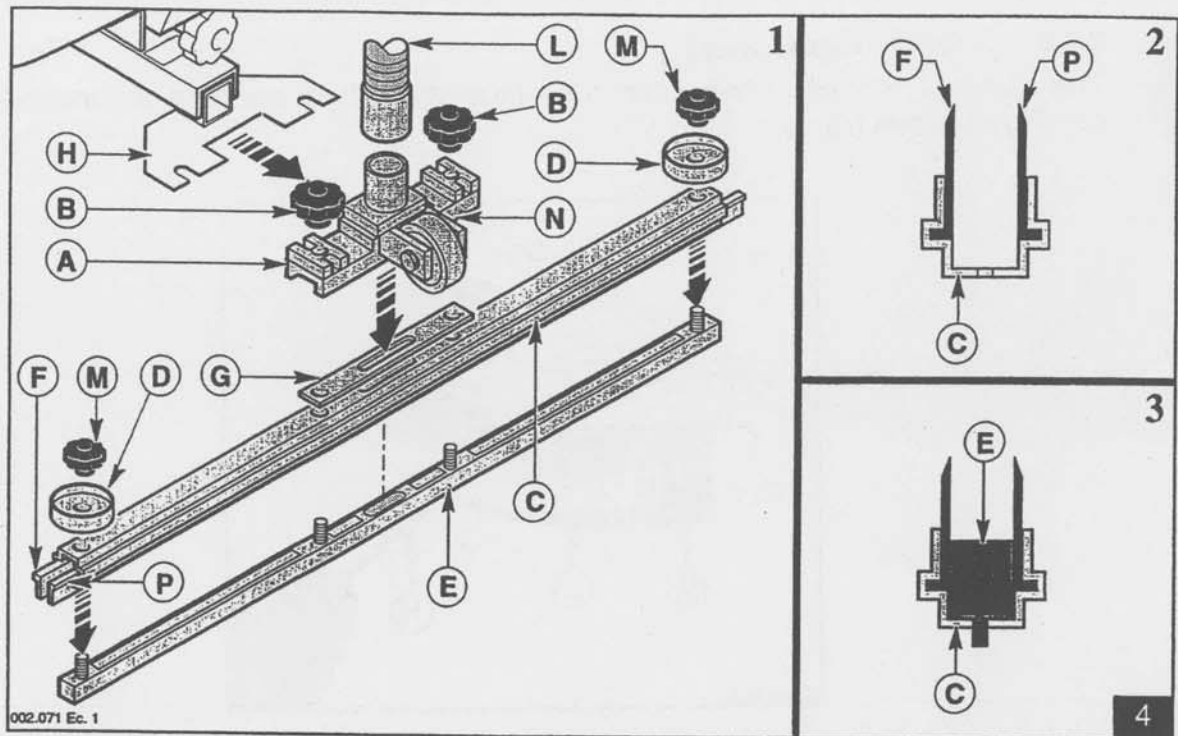

Squeegee reassembly

- Position the extruded part **C** with the hollow facing upwards.
- Insert the two blades **F** and **P** in the extruded part **C** ensuring that they fit perfectly into the guides in the extruded part, rigorously in the position indicated in fig.4.
- Fit the squeegee insert **E** inside the extruded part **C** so that the four threaded pins of the insert are sticking out of the openings.
- Fit the wheels **D** onto the threaded pins sticking out at the ends of the insert and tighten them with the knobs **M**.
- Fit the mouth **A** onto the threaded pins of the extruded part **E**.
- Turn it so that the wheel **N** is as shown in the figure 4.
- Insert the squeegee in the slots in the support **H** and tighten the knobs **B**.
- Finally connect the sleeve **L**.

7.2.5 FLAPS - Replacement

This operation must be performed when the flaps on the head are worn or damaged, proceeding as follows (fig. 5):

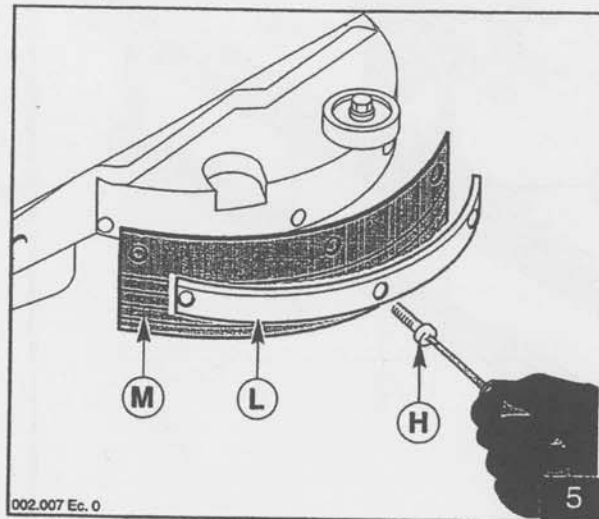

- Unscrew the screws **H**.
- Remove the flap-pressers **L**.
- Change the flaps **M** and put the flap-pressers **L** back in place.

7.2.6 Dirt collecting scraper - Replacement (fig. 6)

The dirt collecting scraper enables the dirt carried along by the brushes to be guided into the collecting box.

If it is damaged, replace it as described below:

- slip out the dirt collecting box **A**.
- replace the damaged scraper with a new one **B** positioning the latter with the wide end **D** towards the machine and the narrow end **C** outwards.

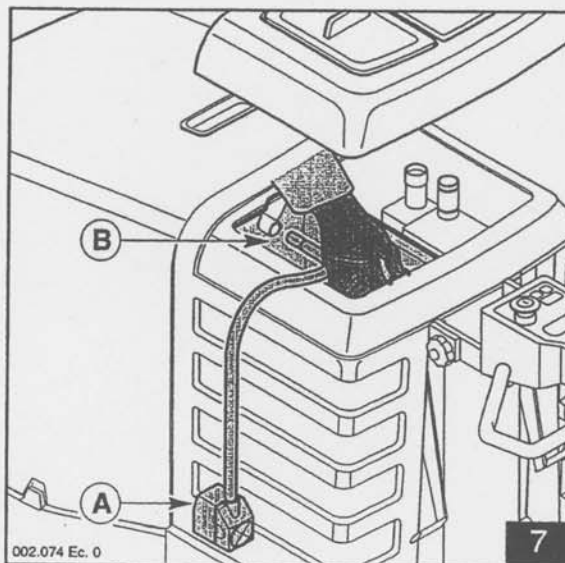
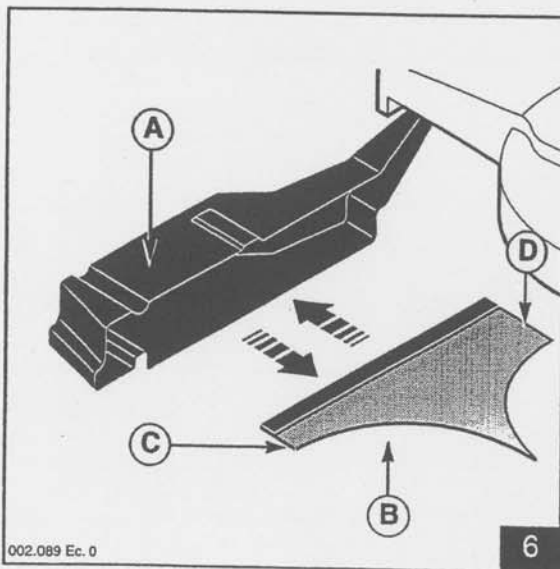

7.2.7 Diaphragm sack - Replacement

In the event of breakage of the diaphragm sack, replace it as follows:

- remove the pump **A** (fig. 7) from the diaphragm sack;
- unhook the frame **C** (fig. 8) and slip out the diaphragm sack **D** (fig. 8);

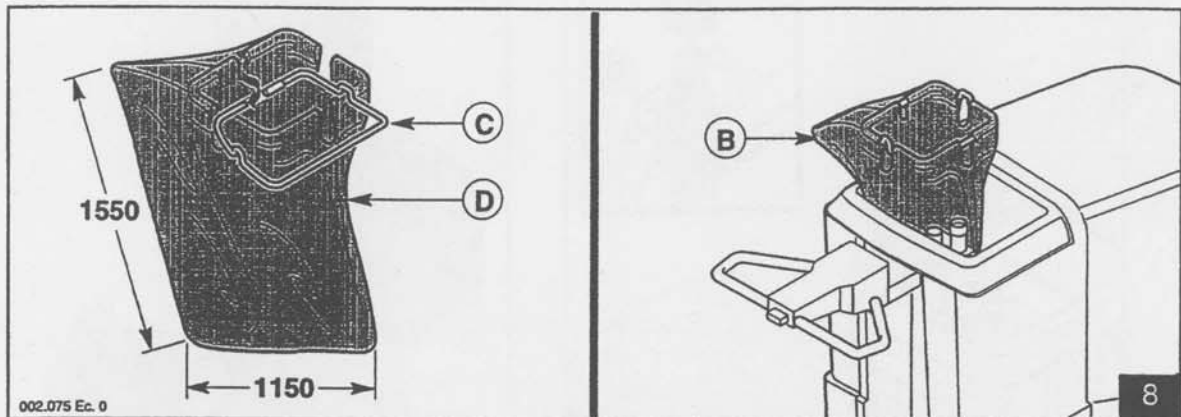

- fit the frame **C** in the new diaphragm sack **D** as in fig. 8 (alternatively, a diaphragm sack with pre-fitted frame is available as spare);
- insert the diaphragm sack, ensuring that it opens up to fill the tank fitting the openings on the sack with the cocks of the squeegee and the suction device inside the tank;



WARNING

**Perform this operation accurately!
Otherwise the sack could be irreparably damaged.**

- hook the frame **C** onto the tank;
- insert the pump in the diaphragm sack, ensuring that it reaches the bottom.

7.2.8 Recycle Accessory - cleaning and replacement

Periodically, when necessary, clean the recycle filter sack, proceeding as follows:

- remove the pump **A** (fig. 7) from the filter sack;
- remove the filter sack **D** (§ 6.6. fig. 5) from the tank and wash it with running water.

Whenever the filtering capacity of the filter sack diminishes, proceed to the replacement of the filtering element (§ 6.6).

7.2.9 Floater - Cleaning (fig. 9)

- Empty the tank. Check that the floater **B** can move easily.
- Disassemble and clean the floater if necessary.

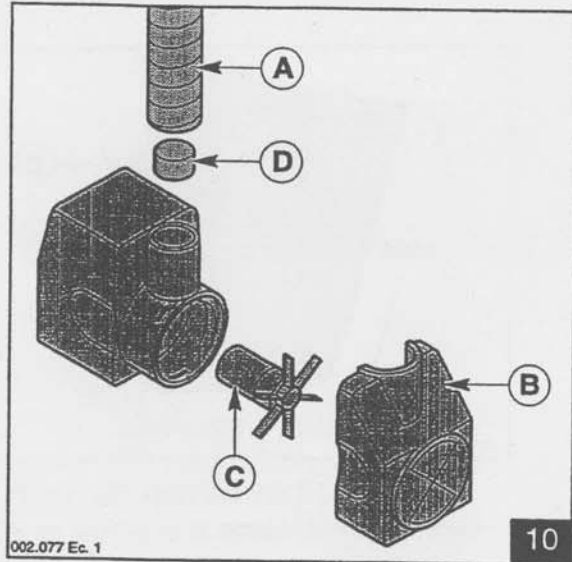
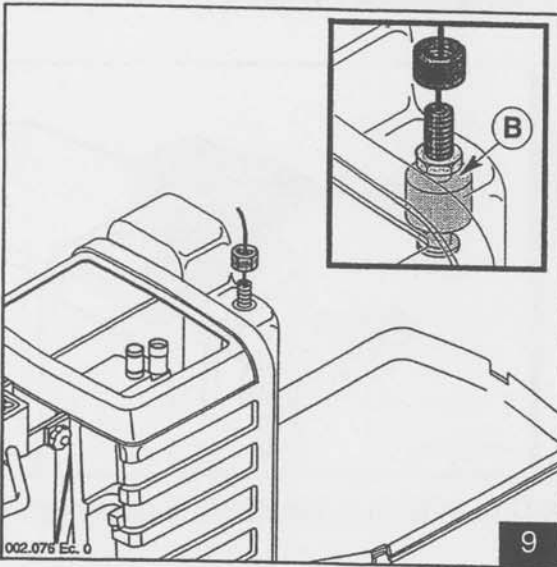

7.2.10 Pump impeller - Cleaning (fig. 10)

- Extract the pump **A** from the diaphragm sack.
- Remove the cover **B**.
- Take out the impeller **C** and clean it.
- Clean the filter **D** on the water delivery.



WARNING

Do not spoil the internal surface of the motor winding.

Reassemble, repeating the operations described in inverse order.

7.2.11 Fuses - Replacement (fig. 11)

- Remove the cover **A**.

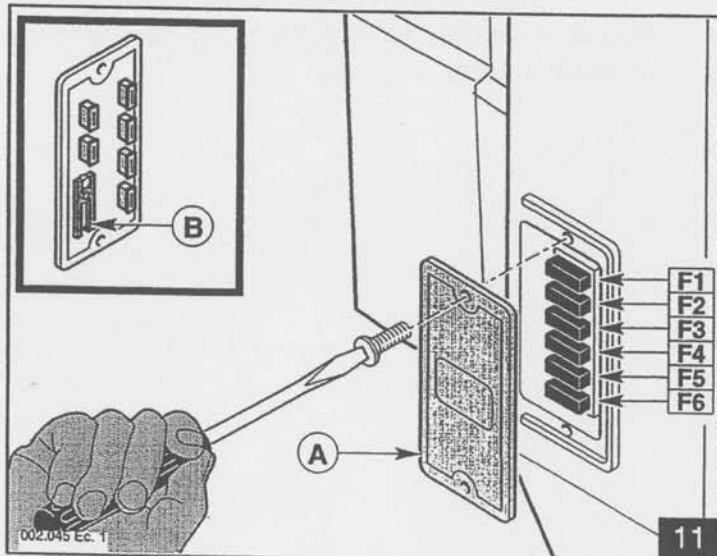

- Change the damaged fuse, using tweezers **B**.

**WARNING**

The fuse F1 must be fitted only if the machine is equipped with gel batteries.

Replacing fuse **F7** (100A) (fig. 12).

- Disconnect the connector **C**.
- Open the drawer **D**.
- Replace fuse **F7** unscrewing the screws **E**.

Fuse chart

For the fuse chart, see the Spare Parts Catalogue.

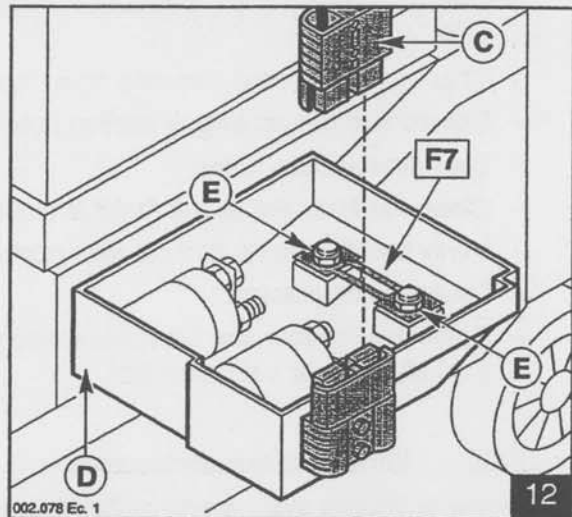
**INFORMATION**

Never fit a fuse with a higher Amp value than the intended one.

If a fuse keeps burning out once it has been replaced, it is necessary to identify and repair the causes in the machine, the cards, the motors or the electric cables.

7.3. PERIODIC MAINTENANCE**7.3.1 Daily maintenance**

Every day, at the end of work, perform the following operations:

- press the emergency button on the control panel to switch off the machine;
- check that the recovery tank is clean;
- check that the inside of the Combi accessory notch is clean, in particular the zone corresponding to the spherical valve;
- check that the dirt collecting box is empty and clean the water drainage holes;
- check that the dirt collecting scraper is not torn or bent;

- clean the filter of the suction motor and check that it is undamaged and, if necessary, replace it;
- clean the squeegee blades, checking that they are not excessively worn and are not torn;
- recharge the batteries;
- when putting away the machine, engage the parking brake, press down the mushroom button and put the key in a safe place.

7.3.2 Weekly maintenance

- Check the level of the electrolyte in the batteries and top up with distilled water if necessary.
- Check and clean the cleaning liquid input hole.
- Ensure that the squeegee suction hole is not blocked, freeing it from any encrusted dirt.
- Clean the suction hose.
- Clean the float and check that it is working correctly.
- Verify that the pump and the filter positioned inside it are clean.
- Clean the diaphragm.
- Clean the inside of the Combi accessory notch corresponding to the spherical valve, using a small brush or a pointed tool.

7.3.3 Six-monthly maintenance

Have the electric system and calibrations checked by skilled personnel.

7.3.4 Preparing for long periods of inactivity

If the machine is to remain unused for a long time, perform the following operations:

- remove the squeegee, wash it and wrap in a bag or a sheet of plastic;
- remove and clean the brushes and the abrasive discs and put them in a dry place, away from dust;
- empty and thoroughly clean the tank and the sack;
- fully recharge the batteries before storing them. Recharge them from time to time (at least once every two months) to keep the batteries constantly at maximum charge.



WARNING

**If the batteries are not recharged periodically
there is a risk of irreparable damage.**

**If the batteries are left on the machine, disconnect the battery connector from
the machine.**

8

TROUBLESHOOTING

8.1. HOW TO OVERCOME ANY PROBLEMS

Possible faults affecting the whole machine.

| FAULTS | CAUSES | REMEDIES |
|---|---|--|
| The machine does not work. | The battery connector is disconnected. | Connect the batteries to the machine. |
| | The emergency mushroom button is pressed or faulty. | Insert the key, turn and release the button or change it. |
| | The main 100A fuse has burnt out. | Check and remove the causes for the burning of the fuse, then change it. |
| | The fuse F6 has burnt out. | Check and remove the causes for the burning of the fuse, then change it. |
| Water is leaking from the diaphragm sack into the tank. | The sack is broken. | Change the sack. |

Possible faults affecting the washing and sweeping head.

| FAULTS | CAUSES | REMEDIES |
|---|--|---|
| The brushes do not turn. | The brush motor remote control switch is faulty. | Change the switch. |
| The head does not go down on command. | The head lifting lever is faulty. | Repair or change it. |
| The machine does not wash evenly. | The brushes or abrasive discs are worn. | Change them. |
| The machine does not sweep correctly. | The dirt collecting box has not been fitted, or it is full. | Empty the dirt collecting box and put it in place. |
| | The dirt collecting scraper is deformed, damaged or missing. | Change the dirt collecting scraper. |
| The brushes keep turning even when the emergency button has been pressed. | The brush remote control switch is faulty. | Disconnect the battery connector and have the remote control switch replaced. |



| FAULTS | CAUSES | REMEDIES |
|---|--|--|
| The solution is not coming out. | The washing head is not working. | Start the washing head. |
| | The solution tank is empty. | Fill it. |
| | The detergent solution sleeve is disconnected. | Reconnect the sleeve. |
| | The built-in no-return valve in the pump does not close correctly. | Check to see if it is clogged, clean it. |
| | There is an obstruction in the pipes that carry the solution. | Remove the blockage and clean the pipes. |
| | The Combi notch is blocked. | Change it. |
| | The pump is faulty. | Repair or change it. |
| | The pump card is faulty. | Change it. |
| Water keeps coming to the brushes even when the machine is switched off | False contact on the pump card. | Repair it. |
| | The breather holes on the detergent solution sleeve are blocked. | Clean the holes. |

Possible faults affecting drying.

| FAULTS | CAUSES | REMEDIES |
|--|--|--|
| The suction motor does not work. | The F4 fuse of the suction motor is burnt. | Change the fuse. |
| | The floater in the tank intervened, is blocked by dirt or is faulty. | Check if the tank is full of dirty water (empty it) or opportunely intervene in the floater. |
| | The pump card is faulty. | Change it. |
| | The suction motor does not work even if supplied directly with power. | Change the suction motor. |
| The squeegee leaves traces of dirty liquid on the floor. | The inclination and/or pressure of the squeegee is not correctly adjusted. | Adjust the squeegee following the specific instructions. |
| | The edge of the blade in contact with the floor is worn. | Change the blade. |
| | There is an obstruction or damage in the squeegee or in the pipe. | Remove the obstruction and have the damage repaired. |

| FAULTS | CAUSES | REMEDIES |
|---|---|--|
| The squeegee does not suck up the dirt. | The tank cover and/or the clean water cover are not perfectly closed. | Close the covers, ensuring that there is a pneumatic seal with the tank. |
| | The recovery tank is full and the suction unit is not working (intervention of the electronic float). | Empty the tank. |
| | The overflow float is blocked by encrustations and the suction unit is not working. | Remove encrustations. |
| | There is a blockage in the suction pipe. | Clear the pipe. |
| | The suction pipe is not connected to the squeegee. | Connect the pipe. |
| | Voltage is not reaching the suction motor. | Check the fuse and have the motor connections checked. |
| | Voltage is reaching the suction motor but the motor is not working. | Change the motor. |
| The suction unit remote control switch is faulty. | Disconnect the battery connector and have the remote control switched replaced. | |

Possible faults affecting the drive system.

| FAULTS | CAUSES | REMEDIES |
|---|--|---|
| The machine does not move forward. | The hand brake is engaged. | Release the brake. |
| | The drive fuse is burnt out. | Identify and remove the cause of the fault and change the fuse. |
| | The motor connector (§ 4.9. fig. 12) is not connected. | Connect it. |
| | The drive motor thermal protection has tripped. | Let it cool for at least half an hour. |
| | There is fault in the motor or in the control unit. | Have the faulty component identified and replaced. |
| | The micro switches and/or the potentiometer of the drive motor faulty or incorrectly adjusted. | Change or adjust them. |

Possible faults affecting the batteries.

| FAULTS | CAUSES | REMEDIES |
|---|---|--|
| The accumulator does not ensure the normal work time. | The accumulator poles and terminals are oxidised. | Clean and grease the poles and terminals. |
| | The electrolyte level is too low. | Add distilled water, topping up each element according to the instructions. |
| | The batter-charger is not working or insufficient. | See the battery charger instructions. |
| | Testing with a densimeter reveals considerable differences between the various elements in the same accumulator. | The accumulator has been damaged: change it. |
| The accumulator discharges too fast during use, although it has been recharged according to instructions and when tested, at the end of recharging, with densimeter reveals fully charged. | The machine is being used with too high pressure on the brushes. | Reduce the pressure on the brushes. |
| | The accumulator is new and does not give 100% of its expected capacity. | It is necessary to "run in" the accumulator by 20-30 complete charges and discharges to obtain maximum performance. |
| | The machine is used with maximum capacity for long, continuous periods and the autonomy is not sufficient. | Use, when possible, accumulators with larger capacity or change them after half the job done, with new, already charged ones. |
| The accumulator discharges too fast during use, the recharging with an electronic battery recharger is too fast and after the accumulator shows the correct tension (about 2.14V for each empty element) but reveals discharged when tested with densimeter. | The electrolyte has evaporated and does not cover the cells completely. | Fill with distilled water, topping up the cells and recharge the accumulator. |
| | The accumulator, already filled with acid by the manufacturer, has been stored too long before recharged and used the first time. | If the recharging with a normal battery recharger is not efficient enough, a double recharging is needed, consisting of: <ul style="list-style-type: none"> - one slow recharging of ten hours with a current equal to 1/10 of the nominal capacity expressed in 5 hours (for example for a battery of 100Ah(5) the current should be 10A). Use a manual battery recharger; - one hour break; - recharge with a normal recharger. |

| FAULTS | CAUSES | REMEDIES |
|--|--|--|
| After recharging with an electronic recharger the accumulator does not show the correct tension (about 2.14V for an empty element) and reveals discharged when tested with densimeter. | The accumulator has not been connected to the recharger (for example the low tension connector has been wrongly connected to the connector of the machine). | Connect the recharger to the accumulator. |
| | The recharger and the socket to which it is connected are not compatible. | Verify that the characteristics of the electric supply indicated on the data plate of the recharger are conform with the electric network. |
| | The recharger is not correctly installed. | Considering the effective tension available, verify that the connections of the primary of the transformer are correct (Consult the recharger's manual for this). |
| | The recharger does not work. | Verify that the recharger receives tension, that eventual fuses are not burnt and that the accumulator receives current, try also to charge with another rectifier: if the recharge actually does not work, contact a Technical Assistant, leaving the serial number of the recharger. |
| After recharging with an electronic recharger the accumulator does not show the correct tension (about 2.14V for an empty element) and when tested with a densimeter only one or a few of the elements are discharged. | One or more elements are damaged. | Change, if possible, the damaged elements. The 6V and 12V unicell accumulators must be changed entirely. |
| The electrolyte inside the accumulator has a turbid colour. | The accumulator has reached maximum amount or charge/discharge recommended by the manufacturer. | Change the accumulator. |
| | A too high current has been used when recharging the accumulator. | Change the accumulator. |
| | The accumulator has been discharged under the minimum level recommended by the manufacturer. | Change the accumulator. |

AS28 28" Automatic Scrubber

Parts Schematic

Item #86003

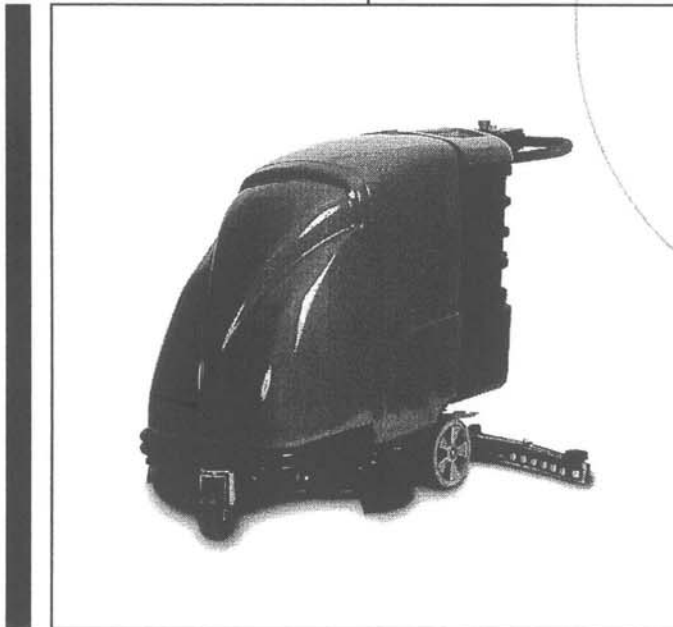

Better Resources. Better Results.
BETCO[®]

CODE:

PF02331BC-3 ab SN from 98K191

DESCRIPTION:

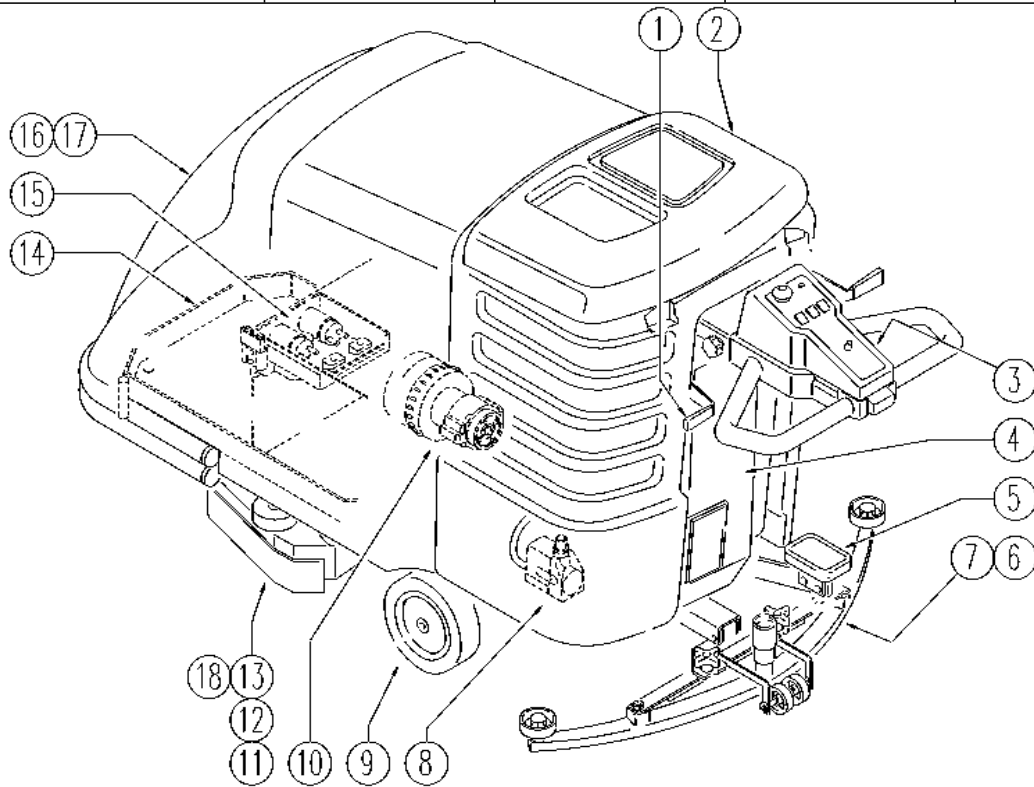

| REF. | CODE | DESCRIPTION | QT |
|------|-----------|-----------------------|----|
| 1 | PL1098 | SQUEEGEE LIFT | |
| 2 | PL1248 | TANK | |
| 3 | PL1252 | ELECTRIC UNIT 3 | |
| 4 | PL1251 | ELECTRIC UNIT 2 | |
| 5 | PL1246 | HEAD LIFT | |
| 6 | PL1253 | SQUEEGEE | |
| 7 | PL1099 | SQUEEGEE SUPPORT | |
| 8 | PL1017 | PUMP | |
| 9 | PL1244BC | DRIVE UNIT AND BRAKE | |
| 10 | PL1101BC | SUCTION | |
| 11 | PL1239 | HEAD 71 :AXLE PULLEY | |
| 12 | PL1240 | HEAD 71 :MOTOR | |
| 13 | PL1241 | HEAD 71 :FLAP AND BOX | |
| 14 | PL1245 | FRAME | |
| 15 | PL1250 | ELECTRIC UNIT 1 | |
| 16 | PL1271BC | HOOD LIFTING | |
| 17 | PL1249BC | EXTERNAL PARTS | |
| 18 | PL1255 | BRUSHES | |
| | WD27057 | ELEC. WIRING DIAGRAM | |
| | WD27057-1 | ELEC. WIRING DIAGRAM | |

CODE:

pl1017 ac SN from 99E000

| DESCRIPTION: | PUMP | PUMPE | POMPE | BOMBA | POMPA |
|--------------|------|-------|-------|-------|-------|
|--------------|------|-------|-------|-------|-------|

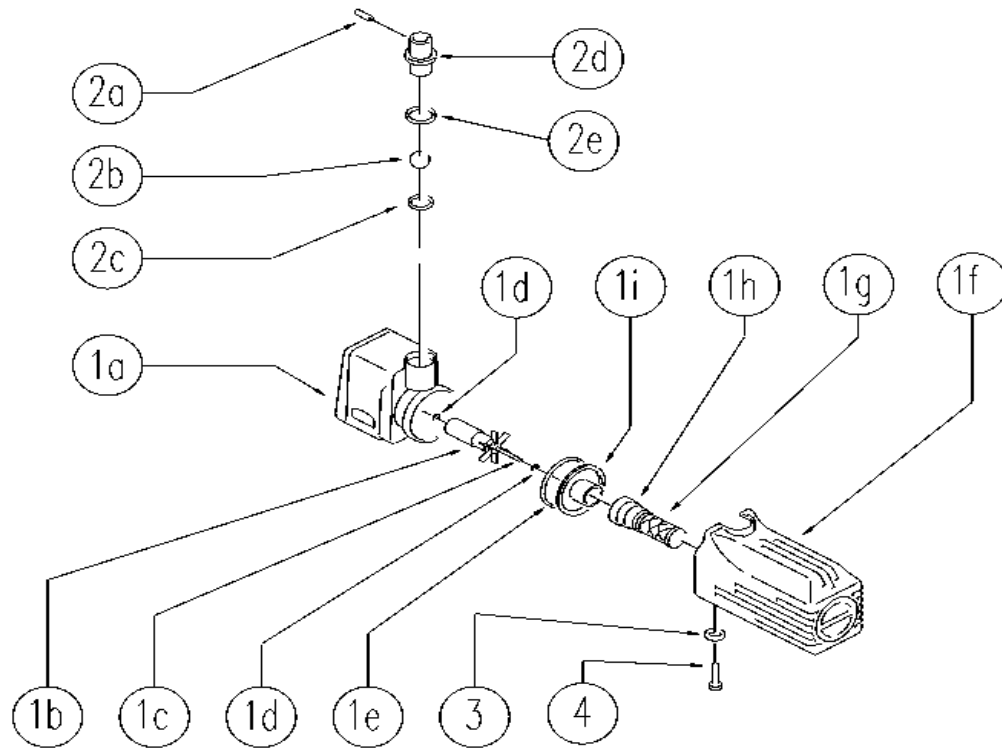

| REF. | CODICE | DESCRIPTION | QT |
|------|-----------|-------------------|----|
| 1 | E86611 | Pump | 1 |
| 1a | SL02125-1 | BODY | 1 |
| 1b | SL02125-2 | ROTOR | 1 |
| 1c | SL02125-5 | PIN | 1 |
| 1d | SL02125-4 | SUPPORT | 2 |
| 1e | SL03402 | GASKET | 1 |
| 1f | SL02125-9 | HOLDER | 1 |
| 1g | E89420 | Pump Filter | 1 |
| 1h | SL18333 | UNION / CONNECTOR | 1 |
| 1i | SL02125-7 | CATCH / LOCK | 1 |
| 2a | E86913 | AS30/36 Pin/Plug | 1 |
| 2b | E86914 | AS30/36 Ball | 1 |
| 2c | E86915 | AS30/36 Gasket | 1 |
| 2d | E86916 | AS30/36 Nozzle | 1 |
| 2e | SL03343 | GASKET | 1 |
| 3 | E86768 | Washer | 1 |
| 4 | E86306 | Screw | 1 |

| | | | | | | |
|--------------|------------------|----------------|--------------------|------------------|--------------------------|--|
| | | CODE: | | | p11098 ab SN from 98L001 | |
| DESCRIPTION: | SQUEEGEE LIFTING | SQUEEGEE-HEBEL | SOULEVEMENT SUCEUR | PALANCA BOQUILLA | SOLLEVAMENTO SQUEEGEE | |

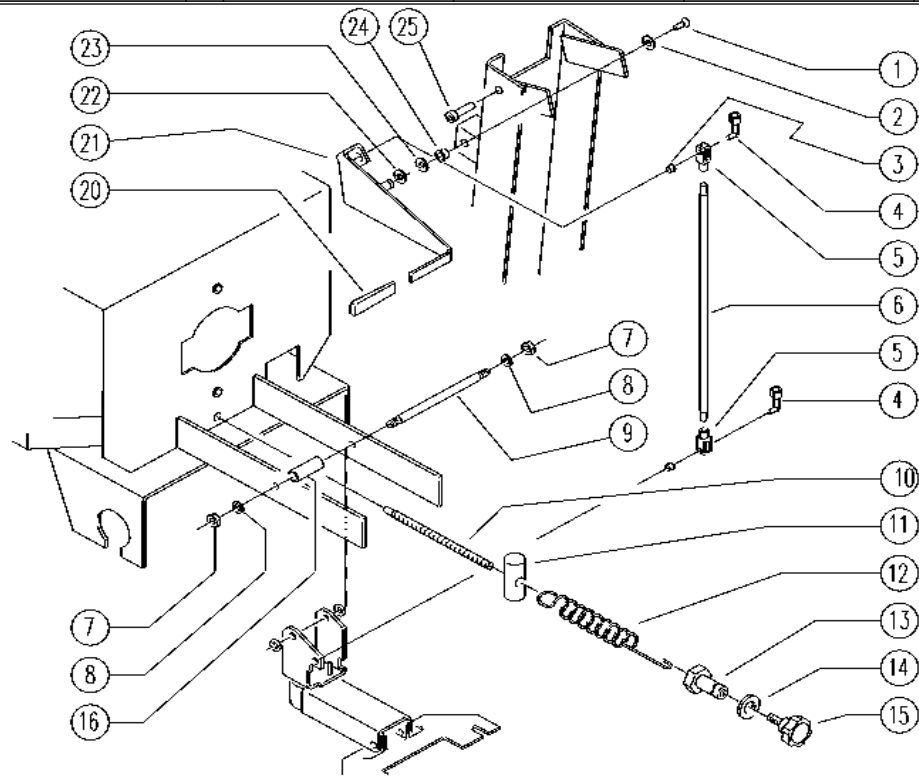

| REF. | CODE | DESCRIPTION | QT |
|------|---------|------------------------|----|
| 1 | SL04149 | SCREW | 1 |
| 2 | E86758 | Washer | 2 |
| 3 | E86680 | AS28 Bushing | 2 |
| 4 | E86673 | Bracket AS24/28 | 2 |
| 5 | E86672 | Fork for AS24/28 | 2 |
| 6 | E86671 | Lift Rod for AS24/28 | 1 |
| 7 | E86853 | Nyloc Hex Nut, M8 Zinc | 2 |
| 8 | E86726 | Washer | 2 |
| 9 | SL07352 | PIN | 2 |
| 10 | E89452 | Bar | 1 |
| 11 | SL07235 | HOOKING / COUPLING | 1 |
| 12 | SL13065 | SPRING | 1 |
| 13 | E89454 | Bushing | 1 |
| 14 | E89455 | Washer | 1 |
| 15 | E86674 | AS28 Knob | 1 |
| 16 | SL07364 | BEARING | 1 |
| 20 | E86450 | Tank Support Handle | 1 |
| 21 | SL09934 | LEVER | 1 |
| 22 | E86490 | AS20 Washer | 1 |
| 23 | SL06040 | WASHER | 3 |
| 24 | E86686 | AS28 Bushing | 1 |
| 25 | E86540 | AS20 Screw M8x10 | 1 |

| | | | | | |
|---------------------|-------------------------|-------------------------|---------------------------------|------------------------------|--------------------------|
| | | CODE: | pl1099 ab SN from 98J992 | | |
| DESCRIPTION: | SQUEEGEE SUPPORT | SAUGFUßHALTERUNG | SUPPORT SUCEUR | SOPORTE ESCURRESUELOS | SUPPORTO SQUEEGEE |

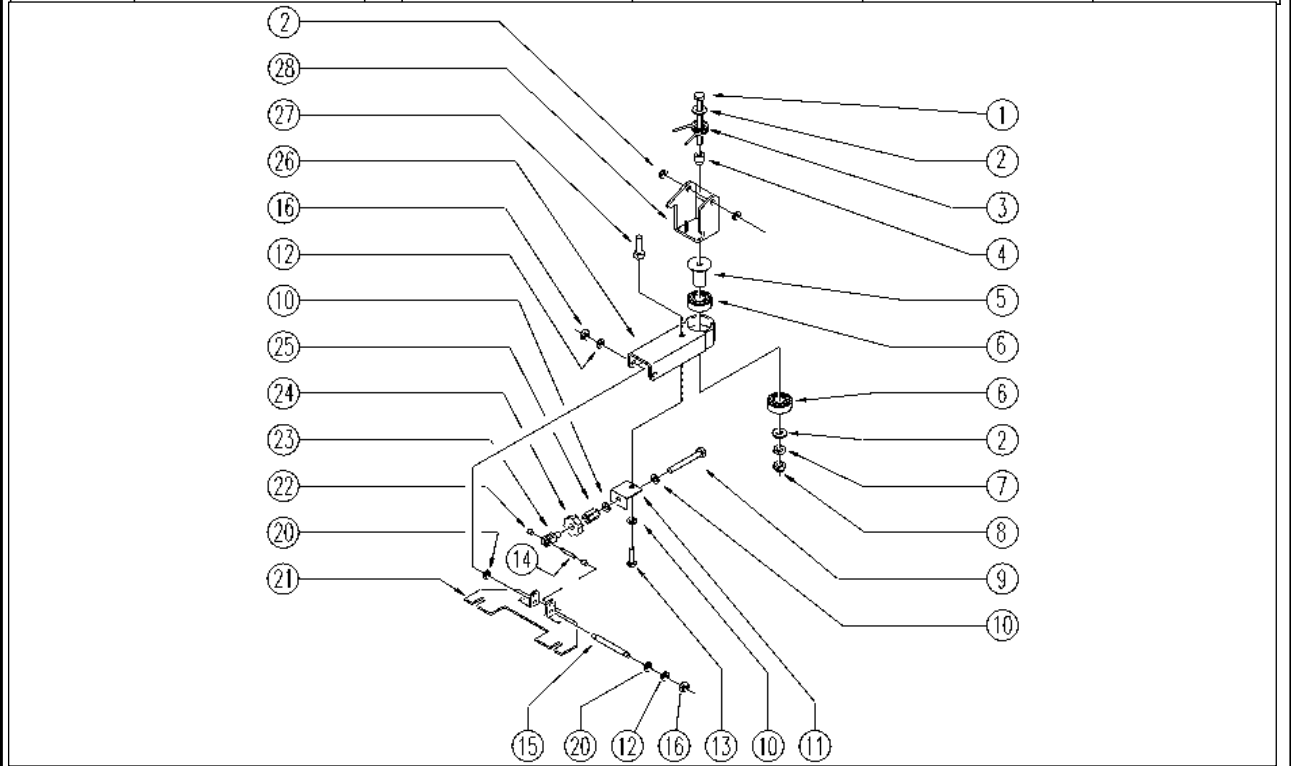

| REF. | CODE | DESCRIPTION | QT |
|------|---------|---------------------|----|
| 1 | SL04116 | SCREW | 3 |
| 2 | E89120 | Washer | 2 |
| 3 | E86731 | Return Spring | 1 |
| 4 | SL07361 | BUSHING / BUSH | 1 |
| 5 | SL07362 | PIN | 1 |
| 6 | E86409 | Bearing, 6005 2RS | 2 |
| 7 | SL05050 | NUT | 1 |
| 8 | E86462 | AS20 Nut | 1 |
| 9 | E86870 | Screw | 1 |
| 10 | E86879 | Washer | 3 |
| 11 | SL09797 | SUPPORT | 1 |
| 12 | E86427 | Washer for AS20 | 2 |
| 13 | E86486 | Screw TE M8-45 | 1 |
| 14 | E86861 | Pin | 1 |
| 15 | SL07400 | PIN | 1 |
| 16 | E86875 | Self-Locking Nut | 2 |
| 20 | E86881 | Washer | 2 |
| 21 | E86679 | AS24 Squeegee Mount | 1 |
| 22 | SL07472 | BEARING | 2 |
| 23 | E86672 | Fork for AS24/28 | 1 |
| 24 | SL06100 | KNOB (o HANDWHEEL) | 1 |
| 25 | SL05081 | NUT | 2 |
| 26 | SL09798 | ARM | 1 |
| 27 | SL07253 | BEARING | 1 |
| 28 | E86688 | AS28 Bracket | 1 |

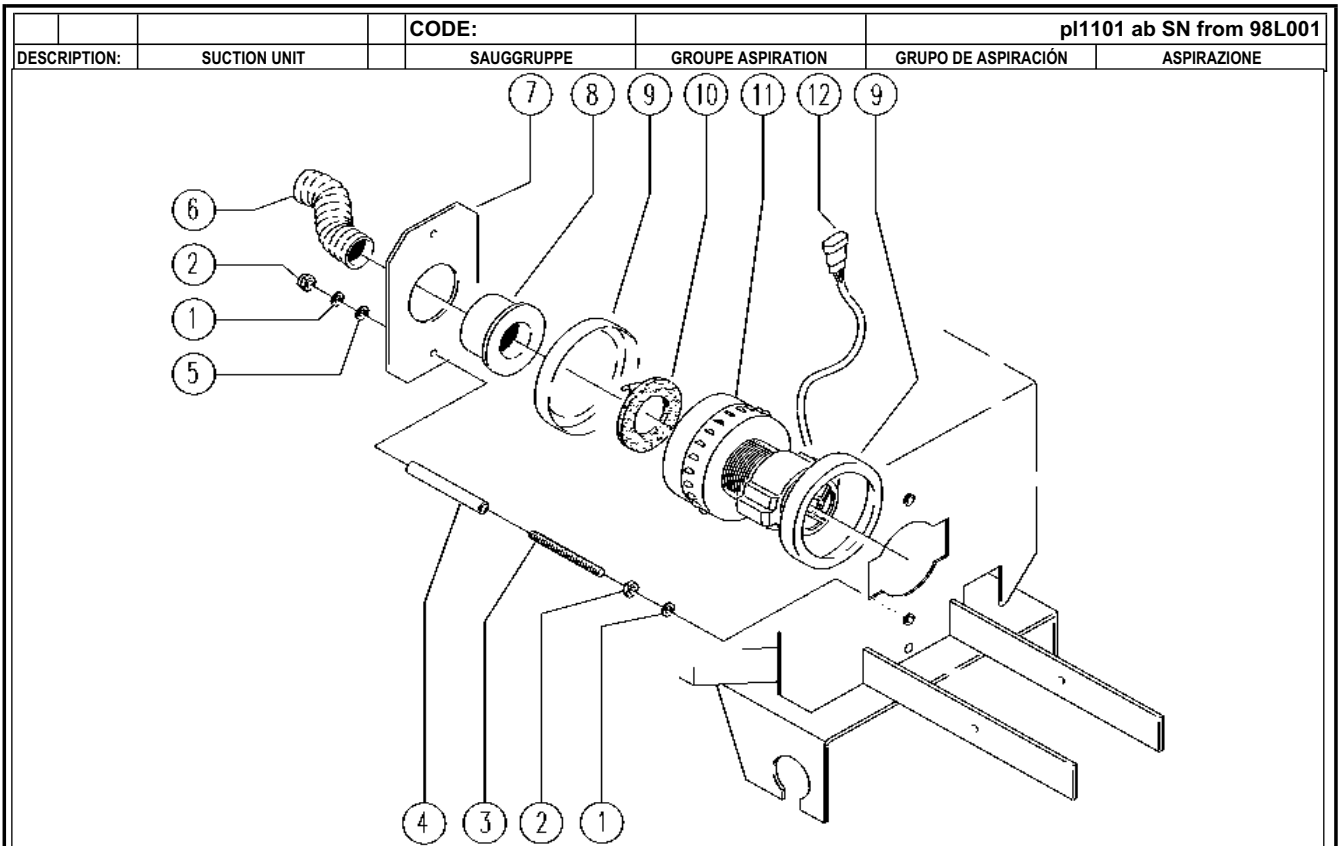

| REF. | CODE | DESCRIPTION | QT |
|------|---------|----------------------------|----|
| 1 | E89183 | Washer | 1 |
| 2 | E86703 | Nut M8 | 2 |
| 3 | SL04232 | BAR | 2 |
| 4 | SL07309 | BAR | 2 |
| 5 | E86726 | Washer | 1 |
| 6 | SL19194 | HOSE | 2 |
| 7 | SL09726 | PLATE | 2 |
| 8 | E86449 | AS20 Bushing for Vac Motor | 1 |
| 9 | E86612 | Gasket for vacuum motor | 2 |
| 10 | E86403 | Gasket for Vacuum Motor | 1 |
| 11 | E86600 | Vacuum Motor Group | 1 |
| 12 | SL23454 | WIRING | 1 |

| | | | | | |
|---------------------|-------------------------|--|--------------|---------------------------------|----------------------------|
| | | | CODE: | pl1239 aa SN from 98L000 | |
| DESCRIPTION: | HEAD:AXLE PULLEY | | KOPF | TETE | CABEZA |
| | | | | | TEST.:ASSE PULEGGIA |

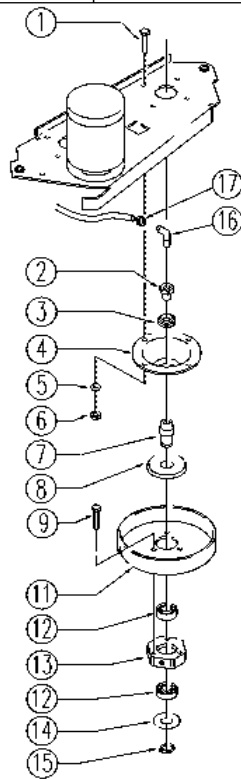

| REF. | CODE | DESCRIPTION | QT |
|------|---------|------------------------|----|
| 1 | SL04023 | SCREW | 10 |
| 2 | E86636 | Nipple | 2 |
| 3 | E86468 | AS20 Nut | 2 |
| 4 | E86725 | Flange, WS20 | 2 |
| 5 | E86726 | Washer | 12 |
| 6 | E86853 | Nyloc Hex Nut, M8 Zinc | 8 |
| 7 | SL07291 | PIN | 2 |
| 8 | E86618 | Upper Protection | 2 |
| 9 | E86977 | Screw TCEI M5-16 | 6 |
| 11 | E86724 | Pulley, pipe | 2 |
| 12 | E86409 | Bearing, 6005 2RS | 4 |
| 13 | E89431 | Hexagon, | 2 |
| 14 | E86617 | Lower Protection | 2 |
| 15 | E86812 | Seeger | 2 |
| 16 | E86638 | Union Elbow | 2 |
| 17 | E86751 | Clamp 10-16 | 2 |

| | | | | | |
|---------------------|--------------------|--------------------|---------------------|--------------------------------|------------------------|
| | | | CODE: | p1240 ad SN from 99G000 | |
| DESCRIPTION: | HEAD :MOTOR | KOPF :MOTOR | TETE :MOTEUR | CABEZA :MOTOR | TESTATA :MOTORE |

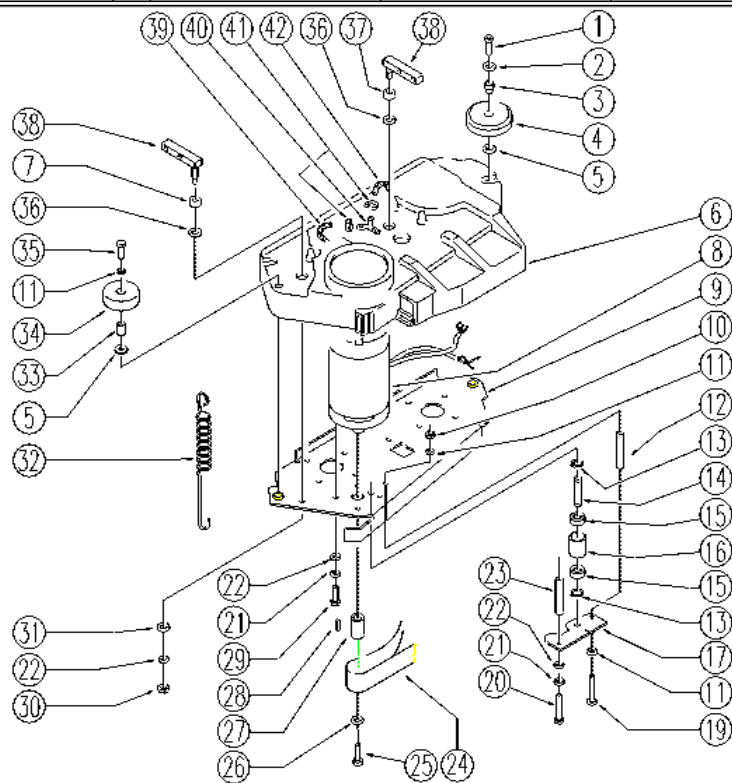

| REF. | CODE | DESCRIPTION | QT |
|------|---------|-----------------------------|----|
| 1 | SL04074 | SCREW | 1 |
| 2 | E86702 | Cham Washer D8 | 1 |
| 3 | E87862 | Spacer WS20/24 | 1 |
| 4 | E86451 | AS20 Wheel | 1 |
| 5 | E86758 | Washer | 2 |
| 6 | SL17285 | CAP / SHELL | 1 |
| 7 | SL03499 | RUBBER SHIM | 2 |
| 8 | E86607 | Brush Motor | 1 |
| 9 | SL09613 | PLATE | 1 |
| 10 | E86738 | Nut M6 w/ Nylon Ring | 1 |
| 11 | E86427 | Washer for AS20 | 2 |
| 12 | E89485 | Spacer | 1 |
| 13 | E89408 | Stop Ring | 2 |
| 14 | E86666 | AS28 Pin | 1 |
| 15 | E86667 | Bearing, 6001 2RS | 2 |
| 16 | E86727 | Neutral Pulley | 1 |
| 17 | E86665 | AS28 Plate (Idler Bearing) | 1 |
| 19 | E87833 | Screw WS20 | 1 |
| 20 | E89220 | Screw | 2 |
| 21 | E89183 | Washer | 4 |
| 22 | E86879 | Washer | 6 |
| 23 | E86555 | spacer | 2 |
| 24 | E86631 | Belt | 1 |
| 25 | E87768 | Screw | 1 |
| 26 | E87757 | Washer | 1 |
| 27 | E87756 | Pulley | 1 |
| 28 | E86536 | Key | 1 |
| 29 | E89182 | Screw | 2 |
| 30 | E86853 | Nyloc Hex Nut, M8 Zinc | 2 |
| 31 | E86881 | Washer | 2 |
| 32 | SL13063 | SPRING | 1 |
| 33 | E86683 | AS24 Wheel Bushing | 1 |
| 34 | E86406 | Wheel D 60 | 1 |
| 35 | SL04067 | SCREW | 1 |
| 36 | E86980 | Washer PPL66 D13-24-2.5 Uni | 2 |
| 37 | E86975 | Rubber Gasket D11.25 L=10 | 2 |
| 38 | SL09629 | BRACKET | 2 |
| 39 | SL19294 | HOSE | 1 |
| 40 | SL18234 | CONNECTOR | 1 |
| 41 | E86751 | Clamp 10-16 | 3 |
| 42 | SL19295 | HOSE | 1 |

| | | | | | |
|--------------|-----------------------|---------|---------|-------------------------|--------------------------|
| | | CODE: | | pl1241 ab SN from 99A20 | |
| DESCRIPTION: | HEAD 71: FLAP and BOX | KOPF 71 | TETE 71 | CABEZA 71 | TEST. 71:FLAP E CASSETTO |

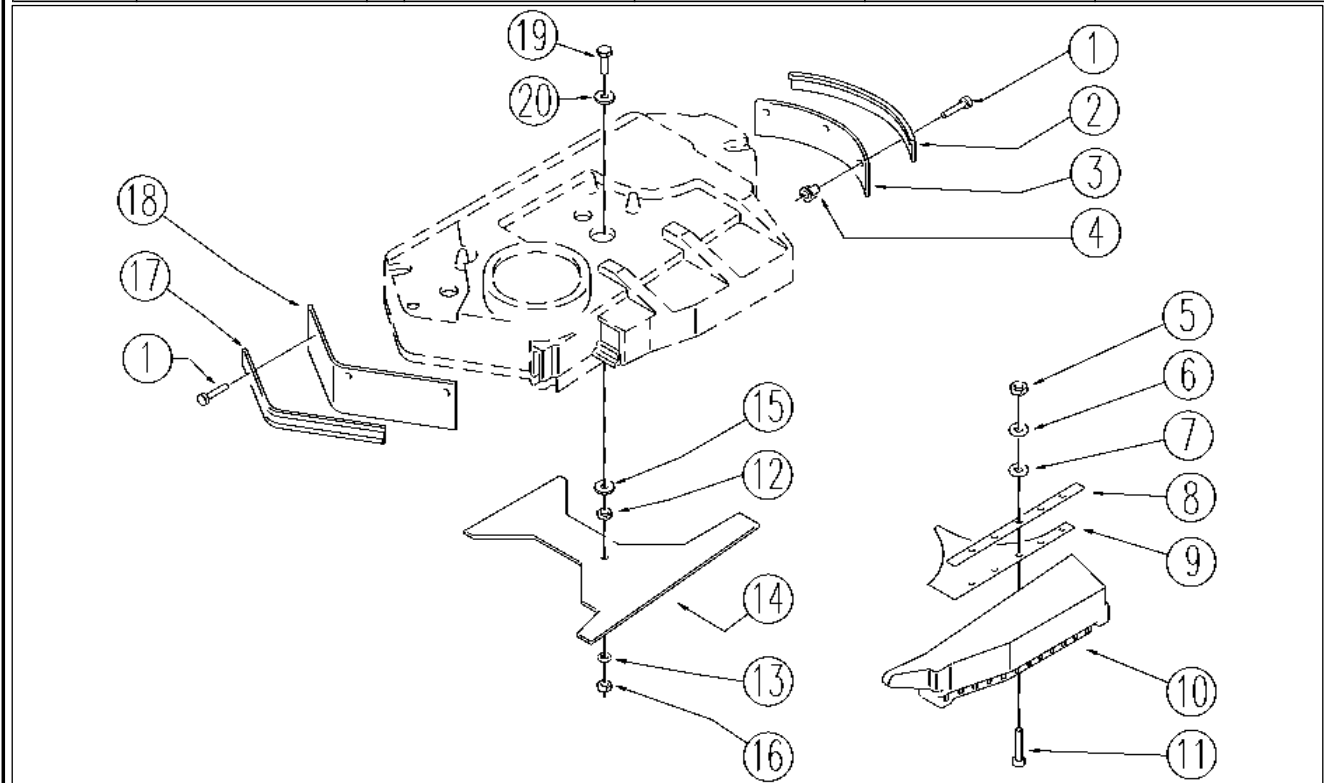

| REF. | CODE | DESCRIPTION | QT |
|------|---------|--------------------------------|----|
| 1 | E86903 | AS30/36 Screw M.4-16 | 9 |
| 2 | E86730 | Flap Fixer | 1 |
| 3 | E86677 | AS28 Right Flap Splash Guard | 1 |
| 4 | E86904 | AS30/36 Nut M.4-Zinc Blk w/Pts | 16 |
| 5 | E86735 | Nut | 4 |
| 6 | E86769 | Washer | 4 |
| 7 | E86768 | Washer | 4 |
| 8 | E89418 | Lamination Strip | 1 |
| 9 | E86886 | Dust Pan for AS28 | 1 |
| 10 | E86885 | Dust Collector for AS28 | 1 |
| 11 | SL04364 | SCREW | 4 |
| 12 | E86875 | Self-Locking Nut | 3 |
| 13 | E86427 | Washer for AS20 | 10 |
| 14 | SL09623 | GUARD | 1 |
| 15 | E86704 | Washer D 6-18 | 4 |
| 16 | E86738 | Nut M6 w/ Nylon Ring | 1 |
| 17 | E86736 | Flap Press | 1 |
| 18 | E86614 | Left Flap AS28 | 1 |
| 19 | E86668 | AS28 Screw | 1 |
| 20 | E86758 | Washer | 1 |

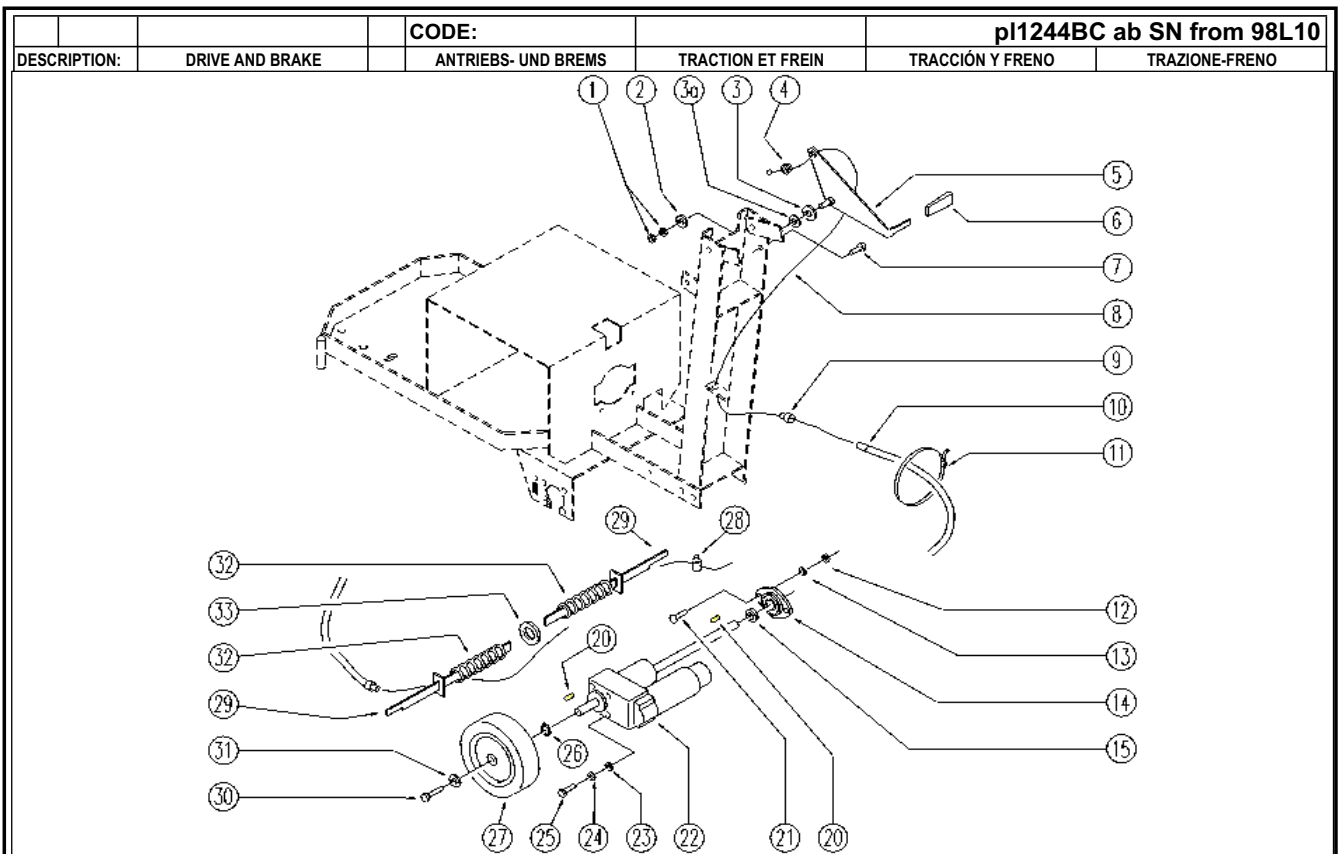

| REF. | CODE | DESCRIPTION | QT |
|------|---------|--------------------------------|----|
| 1 | E86701 | Nut M6 | 2 |
| 2 | E86704 | Washer D 6-18 | 1 |
| 3 | E86490 | AS20 Washer | 1 |
| 3a | SL06040 | WASHER | 1 |
| 4 | SL07236 | BUSHING / BUSH | 1 |
| 5 | SL09637 | LEVER | 1 |
| 6 | E86450 | Tank Support Handle | 1 |
| 7 | SL04235 | SCREW | 1 |
| 8 | SL14095 | CABLE | 1 |
| 9 | SL07231 | BUSHING / BUSH | 2 |
| 10 | SL14173 | SHEATH | 1 |
| 11 | E86460 | Cable tie 12" | 1 |
| 12 | E86853 | Nyloc Hex Nut, M8 Zinc | 2 |
| 13 | E86726 | Washer | 2 |
| 14 | E86627 | Y - Support Bearing Included | 1 |
| 15 | E86626 | Spacer for Bearing | 1 |
| 20 | E89203 | Key | 2 |
| 21 | E89159 | Screw for front cover of | 2 |
| 22 | SL02096 | GEARMOTOR | 1 |
| 23 | E86707 | Cham Washer D10 | 4 |
| 24 | E86700 | Cham Washer D6 | 4 |
| 25 | E86366 | screw WS20 | 4 |
| 26 | SL11094 | RING | 2 |
| 27 | E86495 | Wheel | 2 |
| 28 | E86990 | Terminal D.5,5-2 L7 with Dowel | 2 |
| 29 | SL09638 | ROD | 2 |
| 30 | E86540 | AS20 Screw M8x10 | 2 |
| 31 | E86878 | Washer | 2 |
| 32 | E86410 | Squeegee Spring | 2 |
| 33 | E86855 | Washer | 1 |

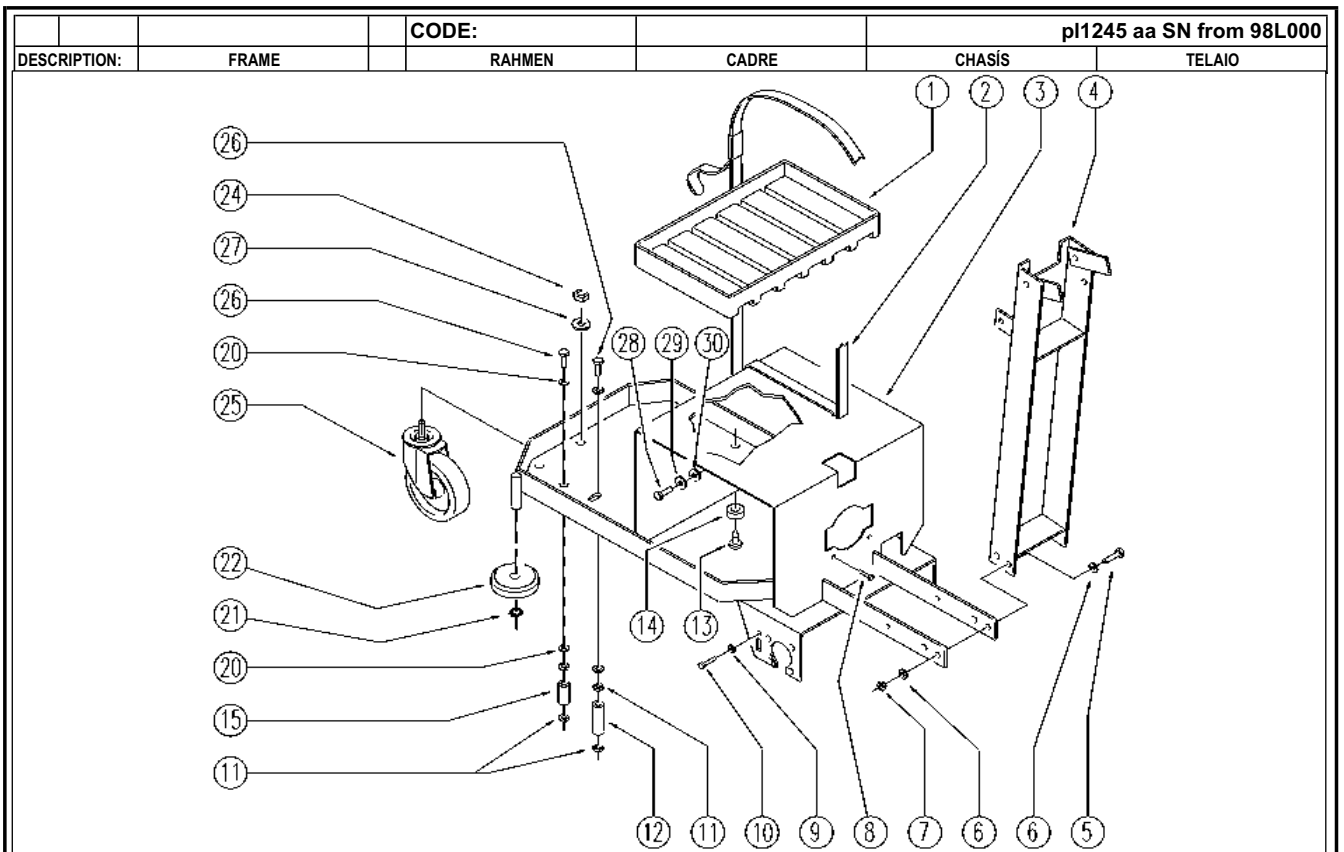

| REF. | CODE | DESCRIPTION | QT |
|------|---------|------------------------|----|
| 1 | SL17287 | PLATE | 2 |
| 2 | E86663 | Battery Strap for AS28 | 2 |
| 3 | SL09642 | FRAME | 1 |
| 4 | SL09933 | STEERING COLUMN | 1 |
| 5 | E89194 | Screw | 4 |
| 6 | E86726 | Washer | 8 |
| 7 | E86853 | Nyloc Hex Nut, M8 Zinc | 4 |
| 8 | SL04222 | SCREW | 2 |
| 9 | E88229 | Washer | 1 |
| 10 | SL04148 | SCREW | 1 |
| 11 | E86462 | AS20 Nut | 4 |
| 12 | SL07238 | BEARING | 1 |
| 13 | SL14148 | BRACKET / CLASP | 1 |
| 14 | SL03104 | RUBBER SHIM | 1 |
| 15 | SL07237 | BEARING | 1 |
| 20 | E88091 | Washer Watchman 24 | 4 |
| 21 | E89408 | Stop Ring | 3 |
| 22 | E86451 | AS20 Wheel | 2 |
| 24 | E86853 | Nyloc Hex Nut, M8 Zinc | 1 |
| 25 | E86624 | Pivoting Wheel | 1 |
| 26 | SL04236 | SCREW | 2 |
| 27 | SL06089 | WASHER | 1 |
| 28 | SL04083 | SCREW | 1 |
| 29 | E86702 | Cham Washer D8 | 1 |
| 30 | SL06053 | WASHER | 1 |

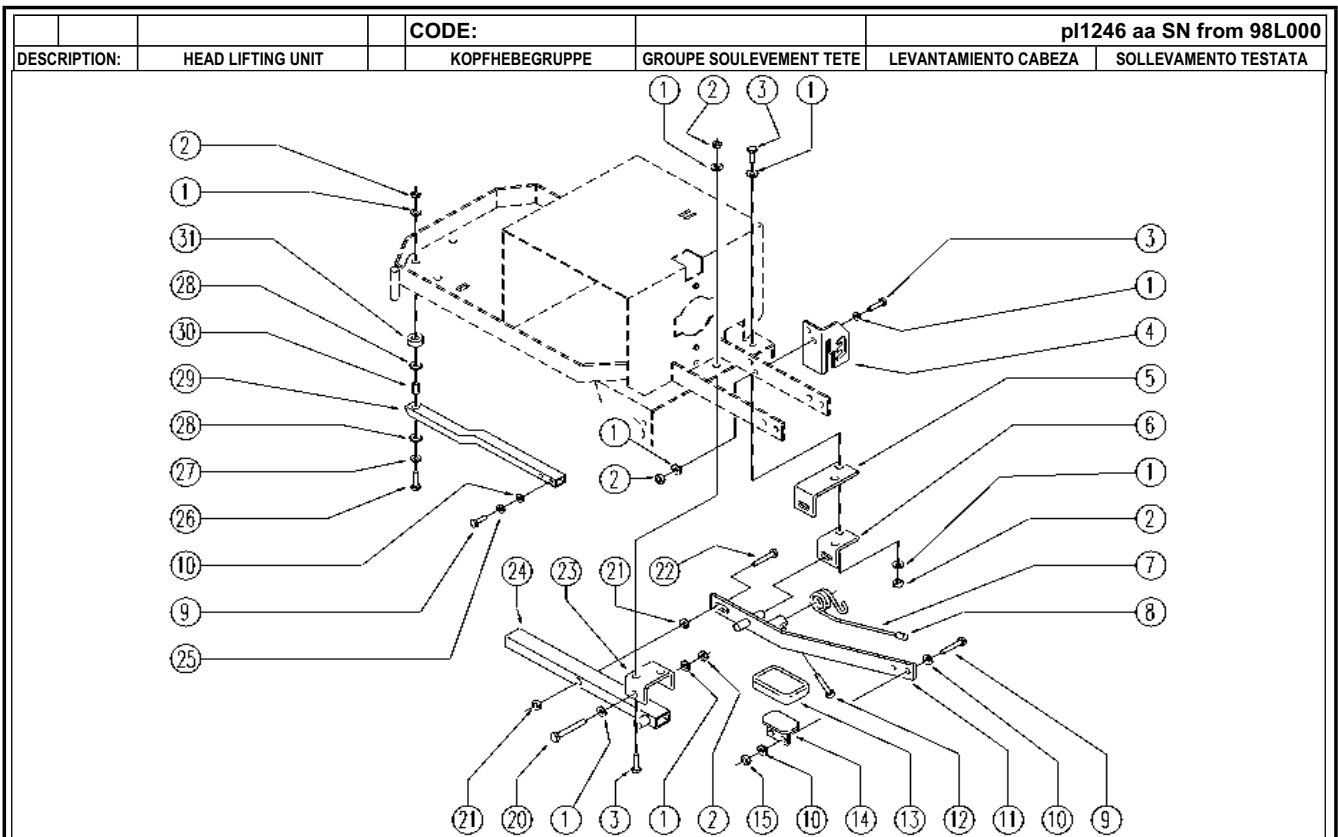

| REF. | CODE | DESCRIPTION | QT |
|------|---------|-------------------------------|----|
| 1 | E86726 | Washer | 11 |
| 2 | E86853 | Nylloc Hex Nut, M8 Zinc | 6 |
| 3 | SL04075 | SCREW | 6 |
| 4 | E86695 | AS24/28 Pedal Selector Spring | 1 |
| 5 | E86326 | Half Fork for AS28 | 1 |
| 6 | E86327 | Half Fork for AS28 | 1 |
| 7 | SL13071 | SPRING | 1 |
| 8 | SL20025 | KNOB (or HANDWHEEL) | 1 |
| 9 | E86668 | AS28 Screw | 4 |
| 10 | E86427 | Washer for AS20 | 6 |
| 11 | E86694 | AS24/28 Lifting Lever | 1 |
| 12 | E86494 | AS20 Screw | 1 |
| 13 | E89419 | Rubber Shim | 1 |
| 14 | SL09133 | PEDAL | 1 |
| 15 | E86552 | nut | 2 |
| 20 | E89257 | Screw | 1 |
| 21 | E86853 | Nylloc Hex Nut, M8 Zinc | 1 |
| 22 | E83703 | Screw M8x60 | 1 |
| 23 | SL09668 | FORK | 1 |
| 24 | SL09669 | LEVER | 1 |
| 25 | E86716 | Cham Washer | 2 |
| 26 | SL04001 | SCREW | 1 |
| 27 | E86979 | Washer D 8-24 Lge Band Zinc | 1 |
| 28 | E86980 | Washer PPL66 D13-24-2.5 Uni | 2 |
| 29 | SL09633 | LEVER | 1 |
| 30 | E86981 | Spacer D 8-12 L=17,5 | 1 |
| 31 | E86975 | Rubber Gasket D11.25 L=10 | 1 |

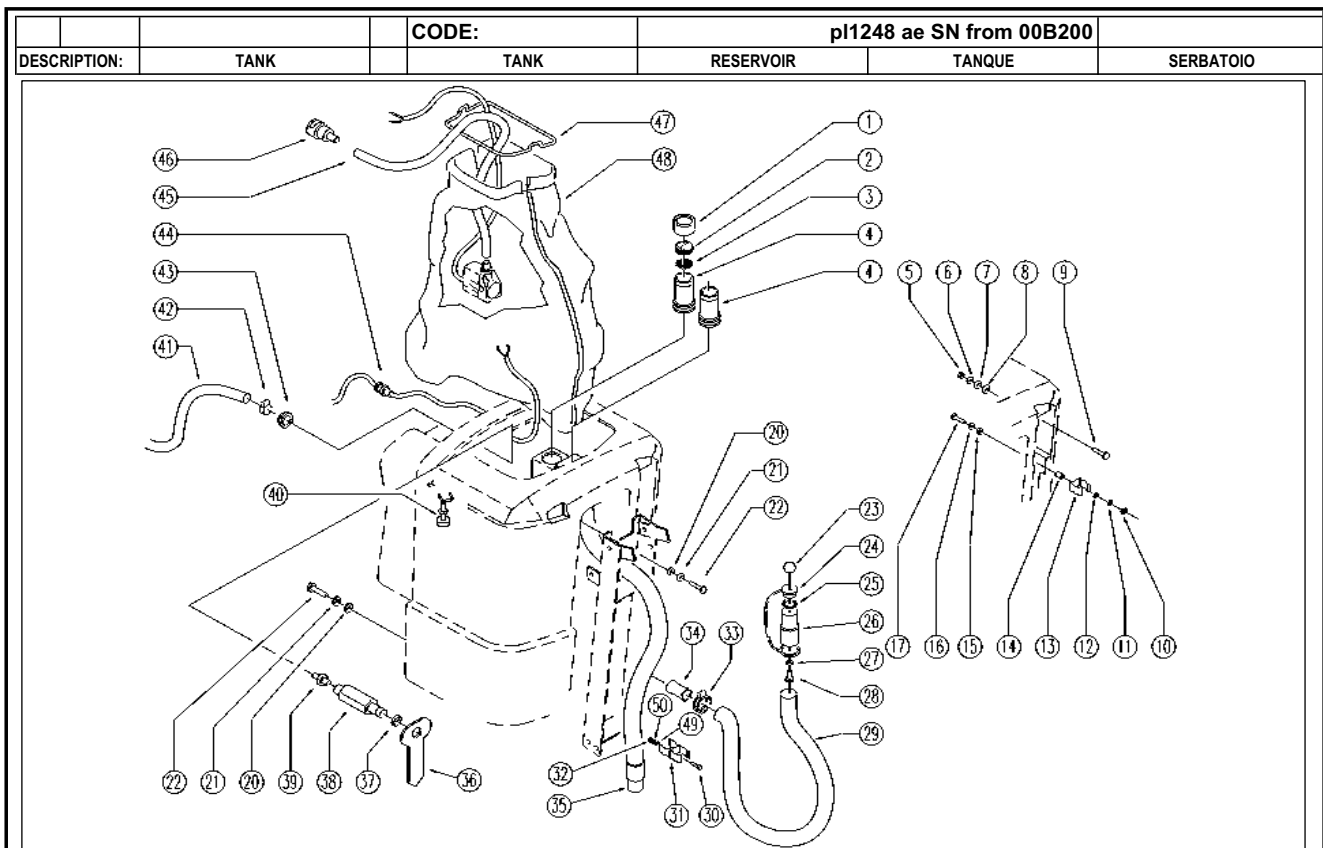

| REF. | CODE | DESCRIPTION | QT |
|------|---------|-------------------------------|----|
| 1 | E86651 | Filter Cap | 1 |
| 2 | E86613 | Vacuum Filter | 1 |
| 3 | E86637 | Vacuum Filter | 1 |
| 4 | SL17293 | NOZZLE | 2 |
| 5 | E86876 | Nut | 1 |
| 6 | E89183 | Washer | 1 |
| 7 | E86878 | Washer | 1 |
| 8 | E86718 | AS20 Washer | 1 |
| 9 | E89159 | Screw for front cover of | 1 |
| 10 | E86873 | Nut | 2 |
| 11 | E86716 | Cham Washer | 2 |
| 12 | E86427 | Washer for AS20 | 2 |
| 13 | E87808 | Hose Clip FS28 | 1 |
| 14 | E86561 | spacer | 2 |
| 15 | E86718 | AS20 Washer | 2 |
| 16 | E86758 | Washer | 2 |
| 17 | E87853 | Screw FS28 | 2 |
| 20 | E86704 | Washer D 6-18 | 3 |
| 21 | E86700 | Cham Washer D6 | 3 |
| 22 | E86737 | Screw | 3 |
| 23 | E86459 | AS20 Knob | 1 |
| 24 | SL14237 | CAP | 1 |
| 25 | E86689 | AS28 Gasket | 1 |
| 26 | E86849 | Sleeve | 1 |
| 27 | E86427 | Washer for AS20 | 1 |
| 28 | E86475 | AS20 Screw TE M .6-20 | 1 |
| 29 | SL19188 | PIPE | 1 |
| 31 | SL13127 | DUCT LOCK | 2 |
| 30 | E86734 | Screw | 2 |
| 32 | E86735 | Nut | 2 |
| 33 | E86480 | Double Wire Clamp | 1 |
| 34 | E86476 | AS20 Membrane Valve - Polyur. | 1 |
| 35 | E86664 | Squeegee Pick-Up Hose | 1 |
| 36 | SL17307 | INDICATOR | 1 |
| 37 | E89439 | Gasket | 1 |
| 38 | E89438 | Coupling | 1 |
| 39 | SL18233 | UNION / CONNECTOR | 1 |
| 40 | E86835 | Floating Switch | 1 |
| 41 | SL19212 | PIPE | 1 |
| 42 | E86751 | Clamp 10-16 | 1 |
| 43 | SL05059 | NUT | 1 |
| 44 | SL23391 | CABLE CLAMP | 1 |
| 45 | E86693 | AS28/30/36 Pipe | 1 |
| 46 | E86692 | AS28 Coupling Clutch | 1 |
| 47 | SL09617 | FRAME | 1 |
| 48 | E86632 | Membrane Bag | 1 |
| 49 | E86768 | Washer | 1 |
| 50 | E86769 | Washer | 1 |

| | | | | | |
|---------------------|-----------------------|----------------------|--------------------------|------------------------|----------------------|
| | | CODE: | pl1249 ad SN from 00E000 | | |
| DESCRIPTION: | EXTERNAL PARTS | EXTERNE TEILE | EXTERNES PARTIES | EXTERNAS PARTES | PARTI ESTERNE |

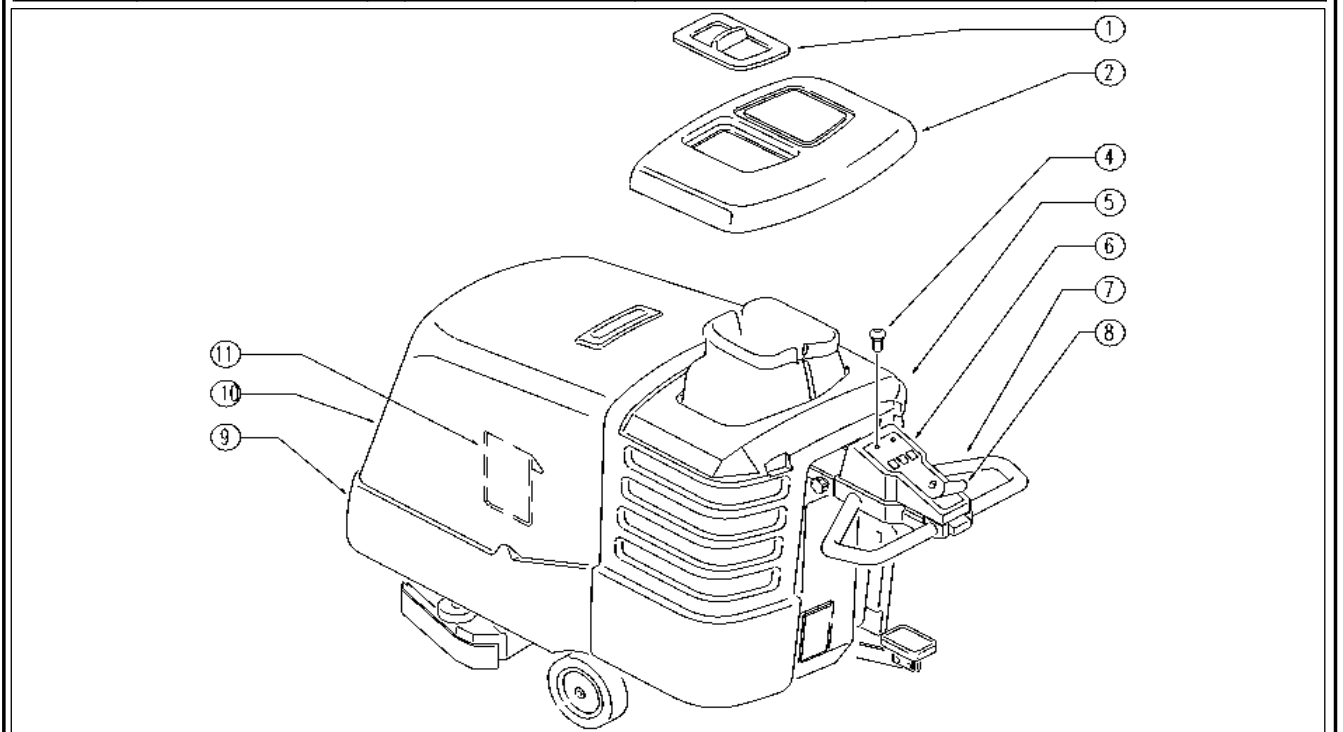

| REF. | CODE | DESCRIPTION | QT |
|------|---------|--------------------------------|----|
| 1 | SL17277 | LID | 1 |
| 2 | E86653 | Complete Tank Cap | 1 |
| 4 | E86988 | Operator D22 Mushroom complete | 1 |
| 5 | SL17272 | TANK | 1 |
| 6 | E86675 | AS28 Control Panel Support | 1 |
| 7 | SL09612 | HANDGRIP | 1 |
| 8 | E86676 | AS28 Panel Label | 1 |
| 9 | SL17274 | BUMPER | 1 |
| 10 | SL17275 | HOOD | 1 |
| 11 | SL25374 | POCKET | 1 |

| | | | | | | |
|--------------|-----------------|----------------------|--------------------|-------------------|--------------------------|--|
| | | | CODE: | | pl1250 aa SN from 98L000 | |
| DESCRIPTION: | ELECTRIC UNIT 1 | ELEKTRISCHE GRUPPE 1 | GRUPE ELECTRIQUE 1 | GRUPO ELÉCTRICO 1 | PARTI ELETTRICHE 1 | |

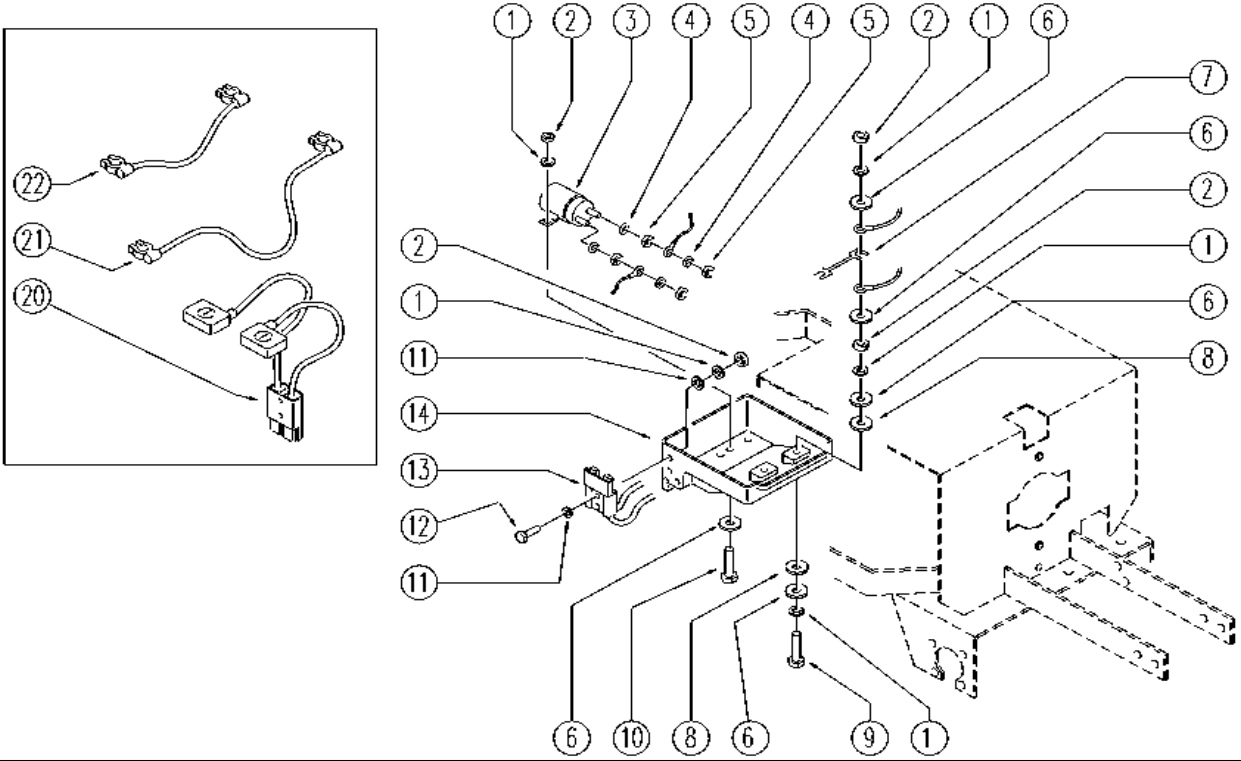

| REF. | CODE | DESCRIPTION | QT |
|------|--------|----------------------|----|
| 1 | E86700 | Cham Washer D6 | 10 |
| 2 | E86701 | Nut M6 | 8 |
| 3 | E86646 | Remote Control | 1 |
| 4 | E86702 | Cham Washer D8 | 4 |
| 5 | E86703 | Nut M8 | 8 |
| 6 | E86704 | Washer D 6-18 | 8 |
| 7 | E86836 | Fuse 100 amp | 1 |
| 8 | E86881 | Washer | 4 |
| 9 | E86705 | Screw TE M 6-30 | 2 |
| 10 | E86706 | Screw TE M 6-16 | 2 |
| 11 | E86707 | Cham Washer D10 | 4 |
| 12 | E86708 | Screw TE M 6-35 | 2 |
| 13 | E11410 | SB175 Red Electrical | 1 |
| 14 | E86661 | Cover for AS28 | 1 |
| 20 | SL2386 | WIRING | 1 |
| 21 | SL2386 | BRIDGE / JUMPER | 1 |
| 22 | SL2301 | BRIDGE / JUMPER | 1 |

| | | | | | |
|--------------|-----------------|----------------------|--------------------------|-------------------|--------------------|
| | | CODE: | pl1251 aa SN from 98L000 | | |
| DESCRIPTION: | ELECTRIC UNIT 2 | ELEKTRISCHE GRUPPE 2 | GRUPE ELECTRIQUE 2 | GRUPO ELÉCTRICO 2 | PARTI ELETTRICHE 2 |

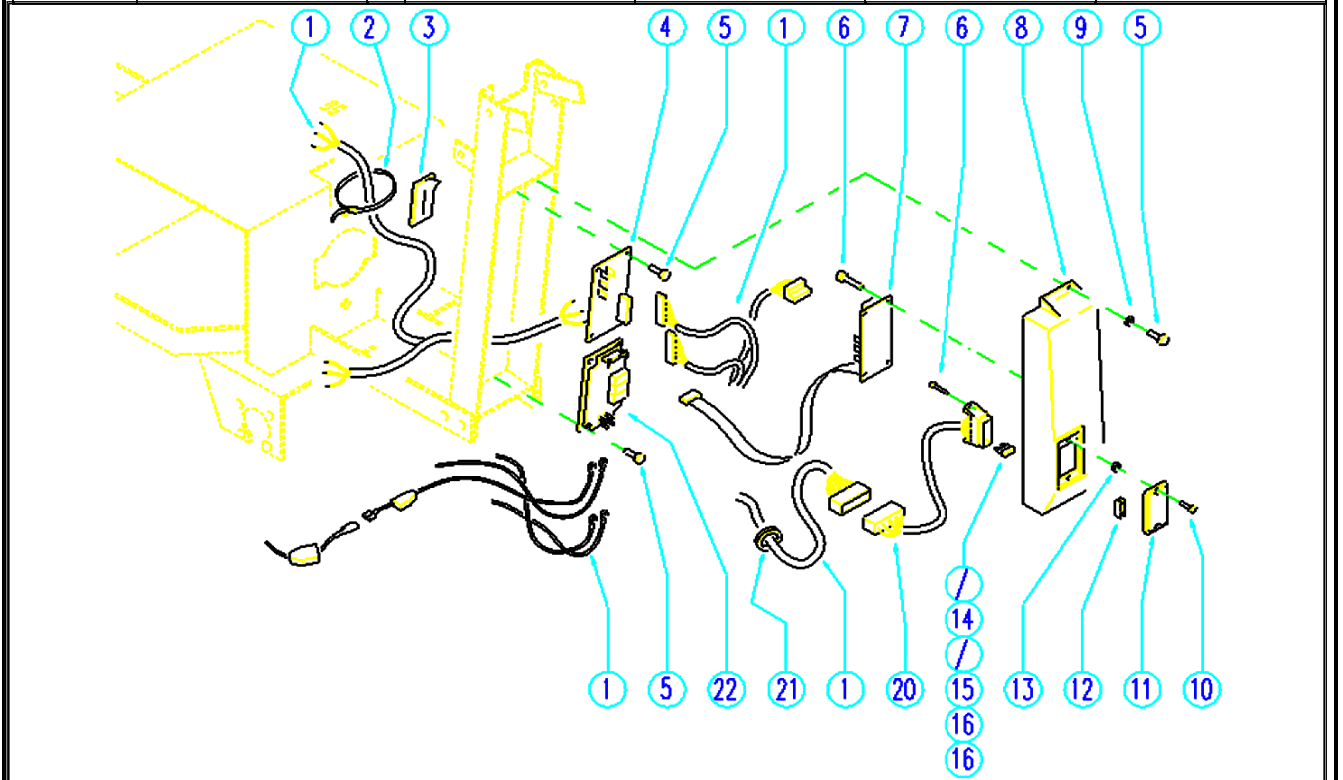

| REF. | CODE | DESCRIPTION | QT |
|------|--------|------------------------|----|
| 1 | SL2344 | WIRING | 1 |
| 2 | E86460 | Cable tie 12" | 1 |
| 3 | SL0321 | GASKET | 1 |
| 4 | E86642 | Pump Card | 1 |
| 5 | SL0414 | SCREW | 10 |
| 6 | SL0417 | SCREW | 6 |
| 7 | E86648 | Interface Card | 1 |
| 8 | SL1716 | COVER | 1 |
| 9 | SL0601 | WASHER | 2 |
| 10 | E86426 | Screw for AS20 | 2 |
| 11 | E86543 | Fuse Cover for AS20 | 1 |
| 12 | SL2320 | FUSE TWEEZERS | 1 |
| 13 | E87876 | Gasket | 2 |
| 14 | E86647 | Fuse 40A | 1 |
| 15 | E89342 | Fuse 30 Amp | 1 |
| 16 | E86825 | Fuse 5 amp | 2 |
| 20 | E89468 | Fuse Carrier | 1 |
| 21 | SL2378 | FAIRLEAD | 1 |
| 22 | E86660 | Control Board for AS28 | 1 |

| | | | | | |
|---------------------|------------------------|-----------------------------|---------------------------------|--------------------------|---------------------------|
| | | CODE: | pl1252 aa SN from 98L000 | | |
| DESCRIPTION: | ELECTRIC UNIT 3 | ELEKTRISCHE GRUPPE 3 | GRUPE ELECTRIQUE 3 | GRUPO ELÉCTRICO 3 | PARTI ELETTRICHE 3 |

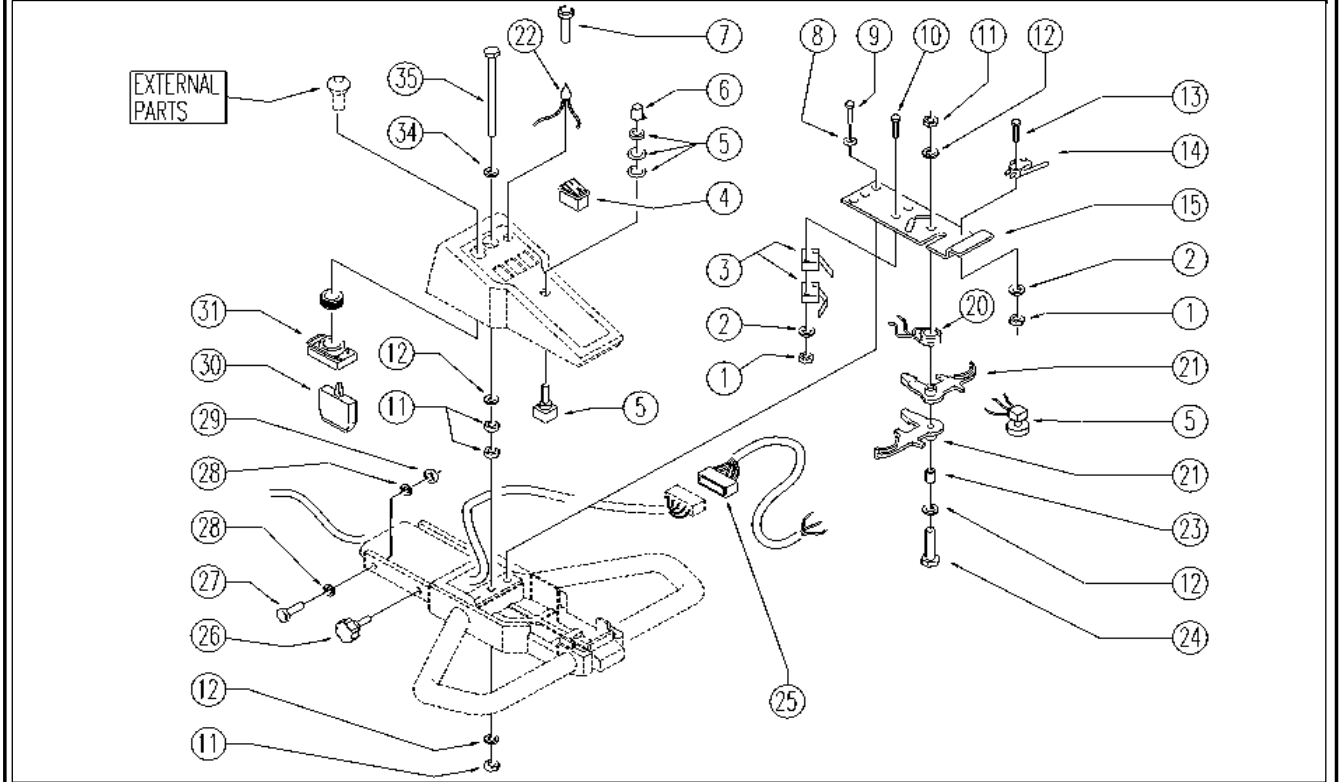

| REF. | CODE | DESCRIPTION | QT |
|------|---------|------------------------|----|
| 1 | E89274 | Nut | 4 |
| 2 | E89275 | Washer | 4 |
| 3 | E86527 | Microswitch | 2 |
| 4 | E86423 | Bipolar Switch | 3 |
| 5 | E86837 | Potentiometer | 2 |
| 6 | E86644 | Knob for Potentiometer | 1 |
| 7 | E86421 | Reflector | 1 |
| 8 | SL06016 | WASHER | 2 |
| 9 | SL04148 | SCREW | 2 |
| 10 | SL04031 | SCREW | 2 |
| 11 | E86552 | nut | 4 |
| 12 | E86707 | Cham Washer D10 | 4 |
| 13 | E86597 | screw | 2 |
| 14 | E86823 | Micro Switch | 1 |
| 15 | SL09616 | PLATE | 1 |
| 20 | SL13061 | SPRING | 1 |
| 21 | E89254 | Control lever AS28 | 2 |
| 22 | E86640 | Control Battery Light | 1 |
| 23 | SL07224 | BUSHING / BUSH | 1 |
| 24 | E86708 | Screw TE M 6-35 | 1 |
| 25 | SL23918 | WIRING | 1 |
| 26 | E86674 | AS28 Knob | 2 |
| 27 | SL04001 | SCREW | 2 |
| 28 | E88091 | Washer | 4 |
| 29 | E86853 | Nyloc Hex Nut, M8 Zinc | 2 |
| 30 | E86988 | Operator D22 | 2 |
| 31 | E86988 | Operator D22 | 1 |
| 34 | E86700 | Cham Washer D6 | 1 |
| 35 | SL04182 | SCREW | 1 |

| | | | | | |
|---------------------|----------|--------------|--------------------------|----------|----------|
| | | CODE: | p11253 ae SN from 00E001 | | |
| DESCRIPTION: | SQUEEGEE | SQUEEGEE | SQUEEGEE | SQUEEGEE | SQUEEGEE |

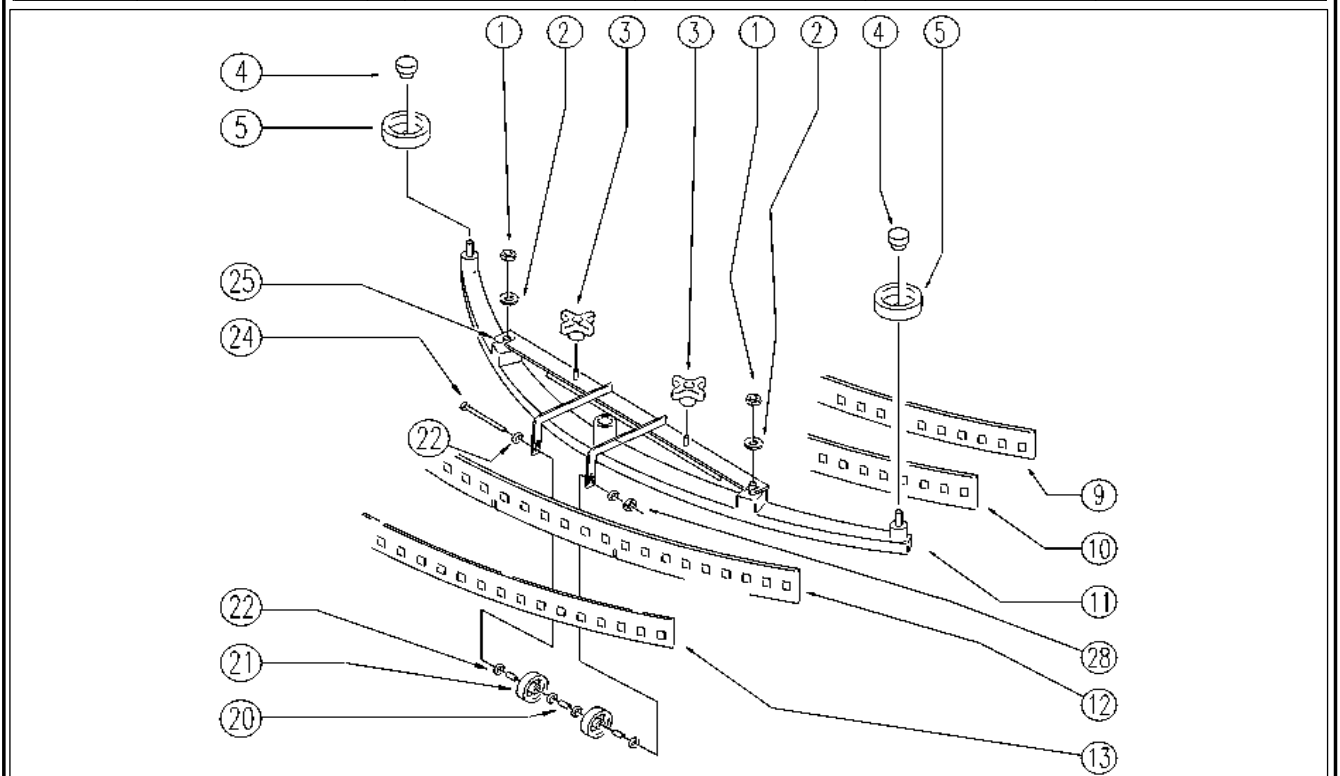

| REF. | CODE | DESCRIPTION | QT |
|------|---------------|----------------------------------|----|
| | E87796 | Complete Squeegee AS24/28 | |
| 1 | E86853 | Nyloc Hex Nut, M8 Zinc | 2 |
| 2 | E86878 | Washer | 2 |
| 3 | SL20056 | KNOB (o HANDWHEEL) | 2 |
| 4 | E86850 | Knob | 2 |
| 5 | E86841 | Squeegee Wheel Guide | 2 |
| 9 | E86325 | AS 24/28" Blade Retainer | 1 |
| 10 | E86323 | AS24/28 Squeegee Blade | 1 |
| 11 | SL01025 | BODY | 1 |
| 12 | E86928 | Squeege Red Blade | 1 |
| 13 | SL03278 | REINFORCEMENT | 1 |
| 20 | E86683 | AS24 Wheel Bushing | 3 |
| 21 | E86406 | Wheel D 60 | 2 |
| 22 | E86427 | Washer for AS20 | 6 |
| 24 | SL04199 | SCREW | 1 |
| 25 | E86897 | Squeegee Strong Support | 1 |
| 28 | E86875 | Self-Locking Nut | 2 |

CODE:

pl1255 aa SN from 98L000

DESCRIPTION: BRUSHES ø340 BURSTEN ø340 BROSSES ø340 CEPILLOS ø340 SPAZZOLE ø340

POLYPROPYLENE - NYLON - NYLON
NYLON - NYLON

1

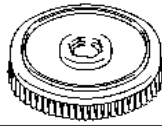

POLYSHING - POLIERBURSTERN
SORGHO - FIBRA - BASSINA

2

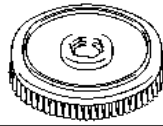

TYNEX - TYNEX - TYNEX
TYNEX - TYNEX

3

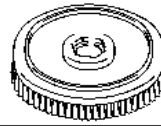

4



BLACK - SCHWARZ - NOIR
PAD - NERO

5

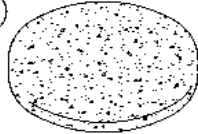

GREEN - GRUEN - VERT
VERDE - VERDE

6

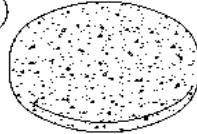

YELLOW - GELB - JEUNE
AMARILLO - GIALLO

7

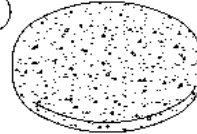

| REF. | CODE | DESCRIPTION | QT |
|------|---------|-----------------------|----|
| 1 | AL02703 | POLYPROPYLENE BRUSH | |
| 2 | AL02707 | POLYSHING BRUSH | |
| 3 | AL02704 | TYNEX BRUSHES | |
| 4 | AL02705 | PAD DRIVER | |
| 5 | AL03510 | STRIPPING PAD(BLACK) | |
| 6 | AL03511 | STRIPPING PAD(GREEN) | |
| 7 | AL03512 | STRIPPING PAD(YELLOW) | |

| | | | | | |
|---------------------|---------------------|--|------------------|---------------------------------|--|
| | | | CODE: | PL1271 aa SN from 981000 | |
| DESCRIPTION: | HOOD LIFTING | | HAUBEHEBE | SOULEVEMENT COFFRE | LEVANTAMIENTO CAPÓ SOLLEVAMENTO COFANO |

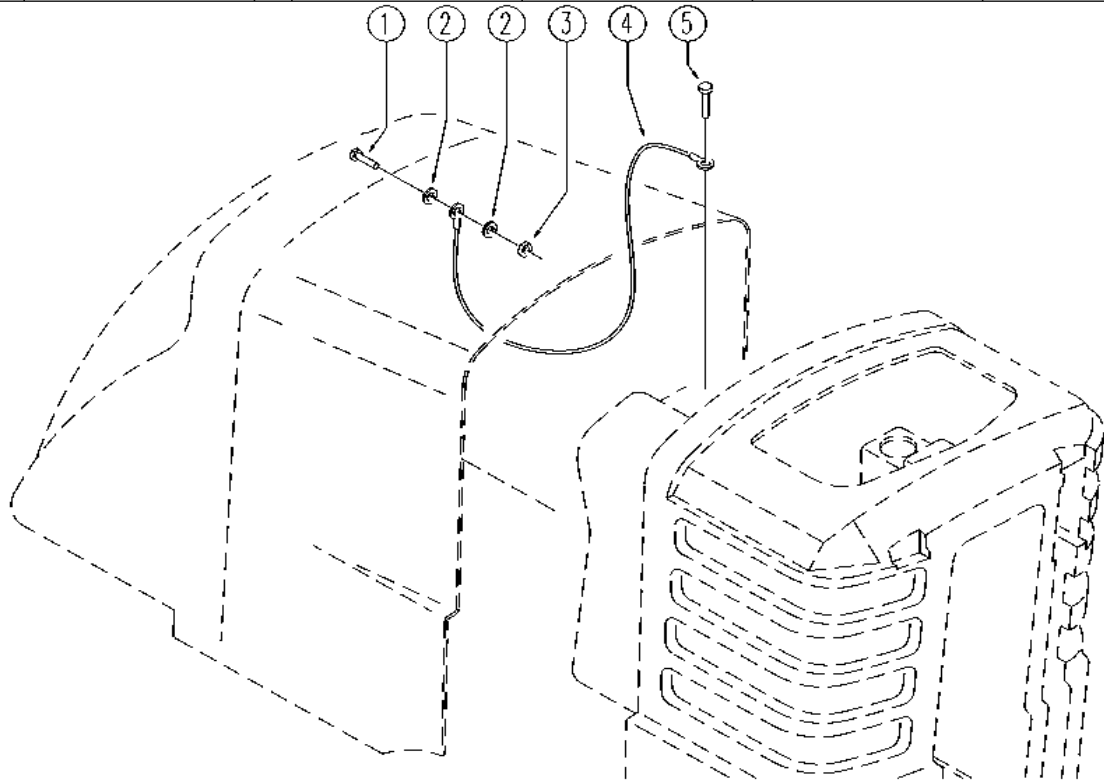

| REF. | CODE | DESCRIPTION | QT |
|------|---------|-----------------|----|
| 1 | SL04161 | SCREW | 1 |
| 2 | E86427 | Washer for AS20 | 2 |
| 3 | E86552 | nut | 1 |
| 4 | SL14220 | TIE ROD | 1 |
| 5 | E86367 | clip WS20 | 1 |

CODE:

WD27057 aa SN from 98L000

DESCRIPTION:

WIRING DIAGRAM

SCHALTPLAN

SCHEMA ELECTRIQUE

ESQUEMA ELECTRICO

SCHEMA ELETTRICO FUNZIONALE

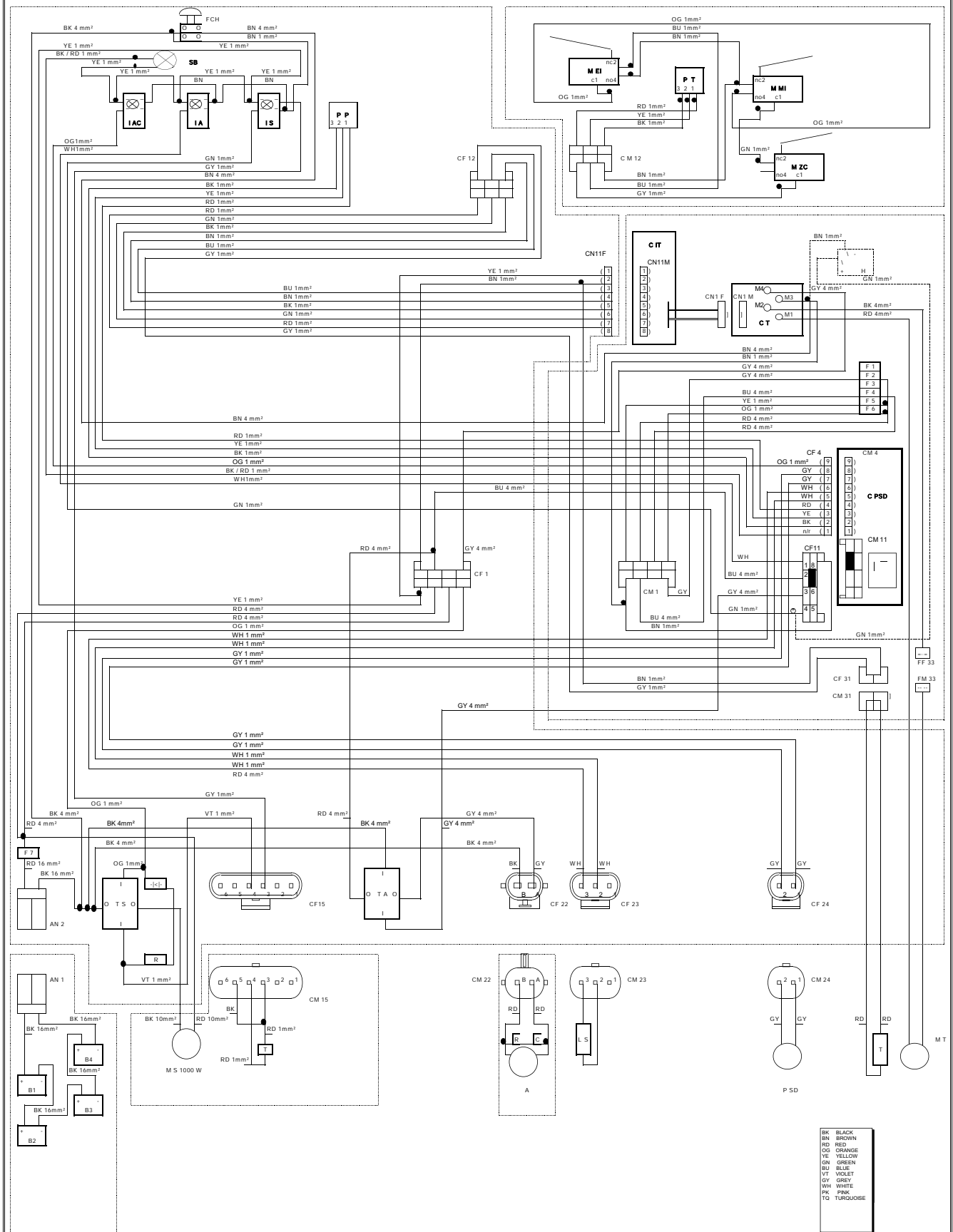

CODE:

WD27057-1 aa SN from 98L000

| REF | CODE | DESCRIPTION | QT |
|------|------|---------------------------|----|
| - < | | DIODE | |
| A | | VACUUM MOTOR | |
| AN# | | CONNECTOR | |
| B# | | BATTERY | |
| C | | FILTERING CONDENSER | |
| CF# | | FEMALE CONNECTOR | |
| CIT | | TRACTION INTERFACE | |
| CM# | | MALE CONNECTOR | |
| CN#F | | FEMALE CONNECTOR | |
| CN#M | | MALE CONNECTOR | |
| CPSD | | DETERG. SOL. POMP CARD | |
| CT | | TRACTION UNIT | |
| F 2 | | TRACTION MOTOR FUSE | |
| F 4 | | ASPIRATOR MOTOR FUSE | |
| F 5 | | UNIT AND PUMP FUSE | |
| F 6 | | FITTING FUSE | |
| F 7 | | MAIN FUSE | |
| FCH | | PUSHLOCK | |
| FF# | | FEMALE FASTON | |
| H | | TIME COUNTER (OPTIONAL) | |
| FM# | | MALE FASTON | |
| I AC | | ACCESSORY SWITCH | |
| I A | | VACUUM SWITCH | |
| I S | | BRUSH SWITCH | |
| LS | | WATER MAX LEVEL PROBE | |
| M# | | CLAMP | |
| MEI | | REAR SAFETY MICROSWITCH | |
| MMI | | REAR RUNNING MICROSW. | |
| MS | | BRUSH MOTOR | |
| MT | | TRACTION MOTOR | |
| MZC | | UNIT ZERO MICROSWITCH | |
| PP | | PUMP POTENTIOMETER | |
| PSD | | DETERGENT SOLUTION PUMP | |
| PT | | TRACTION POTENTIOMETER | |
| SB | | BATTERY LEVEL WARN. LIGHT | |
| T | | MOTOR THERMAL SENSOR | |
| TA | | ASPIRATOR TELESWITCH | |
| TS | | BRUSH TELESWITCH | |

WE RESERVE THE RIGHT TO MODIFY SPECIFICATIONS WITHOUT NOTICE OR OBLIGATION



BETCO

1001 Brown Avenue - Toledo, Ohio 43607 - 1-800-777-9343