

# AS3200T AUTOMATIC SCRUBBER

Chemicals  
Equipment  
Programs  
Process



## 32" Automatic Scrubber

Built rugged for heavy use, this automatic scrubber will compliment any floor care program. Simple controls make training easy. It's large capacity increases productivity and the heavy duty aluminum squeegee assembly provides maximum water recovery.

### Applications

- General cleaning
- Heavy duty cleaning
- Stripping

### Features

- Simple design  
(Easy training and operation)
- Large capacity  
(Enhances productivity)
- Heavy duty aluminum squeegee  
(Provides maximum recovery)
- Self propelled  
(Easy to maneuver)



AS3200T controls and features



### Warranty

Tank: 10 Year  
All other compents: 3 Year (except wear items)\*

\*Please refer to Betco Equipment Price/Product Guide for complete equipment warranty information.

Authorized Betco Distributor

### Specifications

Cleaning path.....	32"
Pad driver.....(2)	13"
Brush motor.....(2)	3/4 hp
Brush pressure.....	Adjustable 80 - 200 lbs.
Brush speed.....	200 RPM
Drive motor.....	5 hp, sealed transaxle
Vacuum motor.....	3-stage, 36 volt
Solution control.....	Gravity feed
Solution tank.....	30 gallon
Recovery tank.....	32 gallon
Length.....	60"
Width.....	25"
Height.....	43"
Weight.....	850 lbs. w/batteries
Volts.....	36 volt system
Batteries.....(6)	6 volt
Run time.....	Approximately 4.5 hours
Tires.....(2)	10" heavy duty nonmarking
Casters.....(2)	5" heavy duty nonmarking
Productivity.....	35,000 sq. ft./hour

### Available In

AS3200T Automatic Scrubber: Item #E12333-00







Literature Item #E12333-92



# TABLE OF CONTENTS

<u>PAGE</u>	<u>DESCRIPTION</u>
3	Table of Contents
<b>4, 5</b>	<b>Safety Instructions – Very Important – Must Read Both Pages</b>
6	Procedures for Loading, Transporting, and Unloading Scrubber
7	Specifications of PowerBuff Automatic Floor Scrubbers
8	Battery Installation and Charging
9	Battery Maintenance
10	Preventative Maintenance
11	Pad Driver and Available Scrubbing Brushes
12	Squeegee Information and Adjustments
13	Brush Operation – How to Raise and Lower Brushes
14	Operating Tips and Miscellaneous Information
15	Scrubber View Descriptions for this Manual
16, 17	Operating Procedures – 2 pages
18	Main Scrubber Parts
19	Scrubber Controls
20	Rear View of Scrubber Showing Parts
21	Dashboard Layout View and Parts and Rear View Parts
22	Solution Tank and Lid Assembly and Parts
23	Recovery Tank Assembly and Parts
24, 25	Recovery Lid Assembly and Parts
26	Splash Skirt Assembly and Parts
27	Squeegee Mount Assembly and Parts
28, 29	Squeegee Assembly and Parts
30, 31	Brush Lift, Motor Mount, and Squeegee Lift, and Parts
32, 33	Motor Frame and Motor Mount and Parts
34	Brush Drive Details and Traction Drive Details
35	Drive Hub Assembly and Parts
36	Handle Assembly (for Brush Drive)
37	Handle Assembly (for Traction Drive)
38	Brush Drive Wheel Mounting Assembly and Parts
39	Transaxle Assembly and Parts
40, 41, 42	Vacuum System and Solution System and Parts
43, 44, 45	Views of Scrubber with Major Plastic Removed
46	Batteries and Charger Parts
47	Electrical Panel and Parts and Other Electrical Information
48	Electrical Layout for Brush Motors and Vacuum Motor
49	Electrical Layout for Traction Drive Portion of Scrubber
50, 51	Trouble Shooting
52	Warranty

# SAFETY INSTRUCTIONS

<u>Hazard Level</u>	<u>Explanation or Description of Hazard Level</u>
	Failure to follow safety instructions labeled  could result in severe injury or death to the machine operator or others.
	Failure to follow safety instructions labeled  could result in injury to the machine operator or others. Also, machine or property damage could occur.
	Failure to follow safety instructions labeled  could result in damage to the machine or damage to other property.



***This manual contains important information about your machine. Read and understand all instructions before operating the machine. Failure to read and follow the instructions could result in injury to the person operating the machine or injury to others. Damage to the machine or other property could occur if instructions are not followed.***



Do not operate this machine around any solvents, thinners, or other flammable liquids or materials. Electrical sparks can cause a fire or even an explosion.



Do not smoke around the machine. Also, keep all sparks and flames away from the batteries. The batteries generate gases that can cause an explosion.



Special care needs to be used when working on or near the batteries. Wear eye protection. Do not lay tools on batteries, as they may short out battery terminals. Do not wear metal jewelry, as it may short out battery terminals.



Charging batteries can be dangerous. Be aware that the battery charger may have a relatively low voltage output, but the current output is very high and therefore dangerous. Do not operate the charger if any parts of the charger or charger cords are damaged. Do not stand on a wet floor when connecting or disconnecting charger to the power outlet or to the machine.

*Safety Instructions are continued on the next page* 

## SAFETY INSTRUCTIONS (continued from previous page)



Battery acid is dangerous. Wear eye and face protection, hand protection, and body protection when working on and around batteries. If you get acid on your skin, wash off immediately. If you get acid on your clothing, remove clothing and wash any skin that was in contact with the clothing. Baking soda mixed with water will help to neutralize the acid on your skin.



The machine is very heavy, so be very careful when loading, transporting, and unloading the machine. Follow the "Procedures for Loading, Transporting, and Unloading Automatic Floor Scrubber" (on a separate page).



Do not pick up dust; machine is for wet pick-up only.



Keep all body parts, clothing, and objects away from moving parts.



Operate machine from the rear, not from the side.



Disconnect a wire to the batteries before working on the machine.



Do not operate machine with charger plugged in.



Do not operate machine with any parts damaged or missing.



Do not operate close to stairs, loading docks, or other drop-offs. Do not park machine in such a manner that it could roll, forward or backward, off a drop-off.



Authorized personnel must perform maintenance and repairs. Do not alter or modify the machine, unless authorized by the manufacturer.



Do not expose the electrical components to water or excessive moisture.



Always put caution signs around the areas that are being cleaned.



Discharge wastewater properly. Improper discharge of wastewater is illegal. Understand and follow all Federal, State, and Local laws regarding disposal of wastewater.



Do not use machine as a "ladder". Do not use machine as a "forklift" to push stuff around. Do not ride or let anyone ride on the machine.



Your machine warranty may be voided if parts other than PowerBuff parts are used.

## Procedures for Loading, Transporting, and Unloading Automatic Floor Scrubber



**The machine is very heavy, so be very careful when loading, transporting, and unloading the machine. Use at least two people to load or unload the machine.**

- Loading Procedure Using a Ramp with a Traction Drive Scrubber
  - Ramp must be long enough so that climb into van, truck, or trailer is no more than 20 degrees. (This would permit a height of 2'4" for a 7-foot ramp, 2'8" for an 8-foot ramp, and 3'0" for a 9-foot ramp).
  - A short "pre-ramp" may be needed to prevent pad drivers from dragging.
  - Ramp must be secured to vehicle, and be clean and dry.
  - Remove squeegee assembly and pad drivers.
  - Machine must be driven straight up the ramp and never at an angle.
  
- Loading Procedure Using a Ramp with a Brush Drive Scrubber
  - It is not recommended that a brush drive scrubber be loaded using a ramp with an incline of more than 7 degrees. The machine is not self-propelled and therefore it is not able to assist itself up a ramp. It is too heavy to manually push up a steep incline.
  - If you must load with a ramp, the incline must be no more than 7 degrees. (This would permit a height of no more than one foot for an 8-foot ramp).
  - Ramp must be secured to vehicle, and be clean and dry.
  - Remove squeegee assembly and pad drivers.
  - Machine must be driven straight up the ramp and never at an angle.
  
- Loading Procedure Using a Lift Gate
  - Lift gate must have ample capacity to lift the scrubber
  - Lift gate must be long enough to accommodate scrubber in the direction that it will be loaded onto the van. Do not load scrubber sideways, because it is dangerous to turn the scrubber while on the lift gate.
  - Wheels must be firmly chocked to prevent scrubber from rolling off the lift gate.
  
- Securing Scrubber
  - Scrubber must be secured, so that it will not roll or turn over. Use chocks and tie downs to secure scrubber.
  - Please be aware that a scrubber is very heavy, and that a metal bulkhead in a van may not contain scrubber in the event of an accident. The equipment in a van can be more dangerous than the accident itself.
  
- Unloading Procedure Using a Ramp with a Traction Drive Scrubber
  - Ramp must be long enough so that removal can be controlled. Use same height restrictions as used for loading scrubber.
  - Ramp must be secured to vehicle, and be clean and dry.
  - A small pre-ramp may be needed to prevent pad drivers from dragging.
  - Machine must be driven straight down the ramp and never at an angle.
  - Use slow forward speed to slow descent as needed.
  
- Unloading Procedure Using a Ramp with a Brush Drive Scrubber
  - Ramp must be long enough so that removal can be controlled. Use same height restrictions as used for loading scrubber.
  - Ramp must be secured to vehicle, and be clean and dry.
  - Machine must be driven straight down the ramp and never at an angle.
  - Do not let machine run over you or anyone else as it comes off ramp.

# AUTOMATIC FLOOR SCRUBBER SPECIFICATIONS

Model	AS2600B	AS2600T	AS3200
Scrub Path	26" offset head	26" offset head	32" symmetrical head
Coverage	30,000 sq. ft. / hour	30,000 sq. ft. / hour	38,000 sq. ft. / hour
Battery Pack	24 volt system	24 volt system	36 volt system
Charger	24 volt - 20 amp	24 volt - 20 amp	36 volt - 20 amp
Run Time	4.5 hours	4 hours	5.5 hours
Vacuum Motor	1 HP - 3 stage	1 HP - 3 stage	1 HP - 3 stage
Brush Motors (Two)	3/4 HP - 200 rpm	3/4 HP - 200 rpm	3/4 HP - 200 rpm
Drive System	Brush Assisted	1/2 hp sealed transaxle	1/2 hp sealed transaxle
Wheels	Front: two 10" solid Rear: two 5" castors	Front: two 10" solid Rear: two 5" castors	Front: two 10" solid Rear: two 5" castors
Tank Construction	Rotational molded polyethylene	Rotational molded polyethylene	Rotational molded polyethylene
Solution tank	24 gallon	24 gallon	24 gallon
Recovery tank	26 gallon	26 gallon	32 gallon
Brushes	Two 13" pad holders (Brushes are optional)	Two 13" pad holders (Brushes are optional)	Two 16" pad holders (Brushes are optional)
Forward Speed	Walking speed	Variable to 290 ft/min (3.3 mph)	Variable to 290 ft/min (3.3 mph)
Reverse Speed	Walking speed	Variable to 145 ft/min (1.6 mph)	Variable to 145 ft/min (1.6 mph)
Brush Pressure	80 lbs and 200 lbs	80 lbs and 200 lbs	80 lbs and 220 lbs
Brush Lifting	Mechanical	Mechanical	Mechanical
Squeegee	34" heavy duty curved tracking squeegee	34" heavy duty curved tracking squeegee	40" heavy duty curved tracking squeegee
Dimensions (no skirt, no squeegee)	52" long 25" wide 43" tall	52" long 25" wide 43" tall	60" long 25" wide 43" tall
Weight with Batteries	685 lbs.	710 lbs.	850 lbs.
Warranty	5 years on parts 10 year on tanks	5 years on parts 10 year on tanks	5 years on parts 10 year on tanks

# BATTERY INSTALLATION AND CHARGING

## BATTERY INSTALLATION

- Turn off all switches.
- Drain solution tank and recovery tank.
- Disconnect recovery dump hose from hooks on rear of machine so that recovery tank can lift.
- Lift recovery tank lid and tilt up recovery tank.
- Install batteries as shown on figure 1.

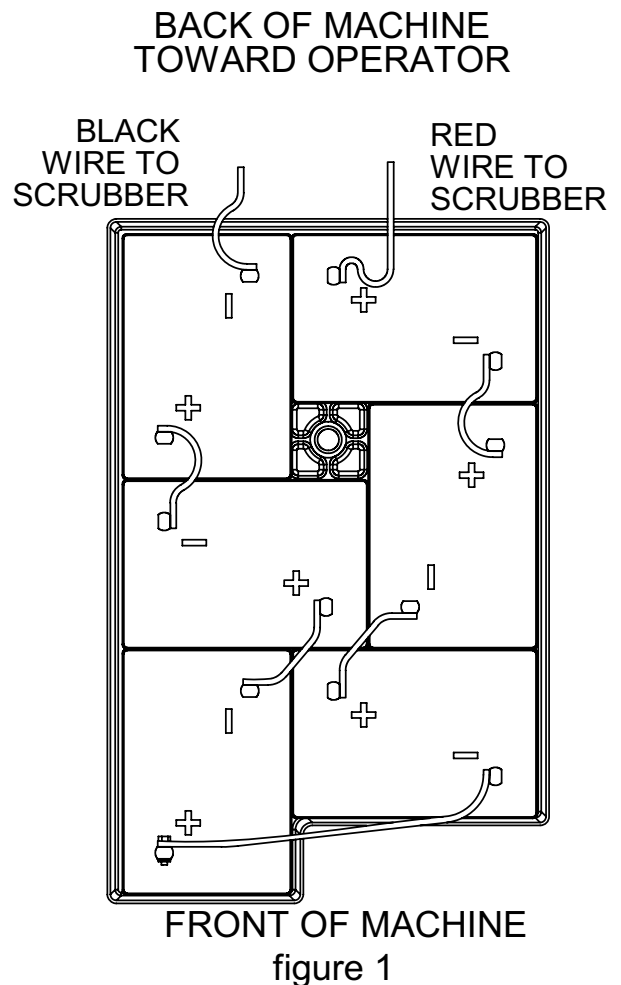

## BATTERY CHARGING

- Place the charger on a safe place. Make sure that air can circulate around the charger. Do not get the charger wet.
- All switches on scrubber must be off.
- Do not remove battery caps (the caps are vented).
- Do not charge scrubber in a wet area.
- Do not stand in a wet area when plugging in charger to the 110 volt receptacle or plugging into the scrubber.
- Connect the charging plug from the charger to the charging plug on the back of the scrubber (item 16)
- Plug in the charger to a properly grounded 110 volt receptacle.
- Indicator needle will rise and then will fall slowly as batteries charge.
- Charger will shut off automatically when batteries are fully charged.



# BATTERY MAINTENANCE

- To receive the longest life from the batteries, charge them when they have between 25% and 50% of a full charge.
- Do not allow batteries to remain in a discharged state for very long, as this shortens the total battery life.
- Be aware that a discharged battery will freeze easily.
- Check the electrolyte level weekly. Top off with distilled water as shown in figure 2. Do not overfill. Make sure that all plugs are tight.
- Make sure battery connections are tight and free from corrosion. A baking soda and water solution and a wire brush are helpful when cleaning battery connections. Keep caps on when cleaning batteries, so that electrolyte is not contaminated.

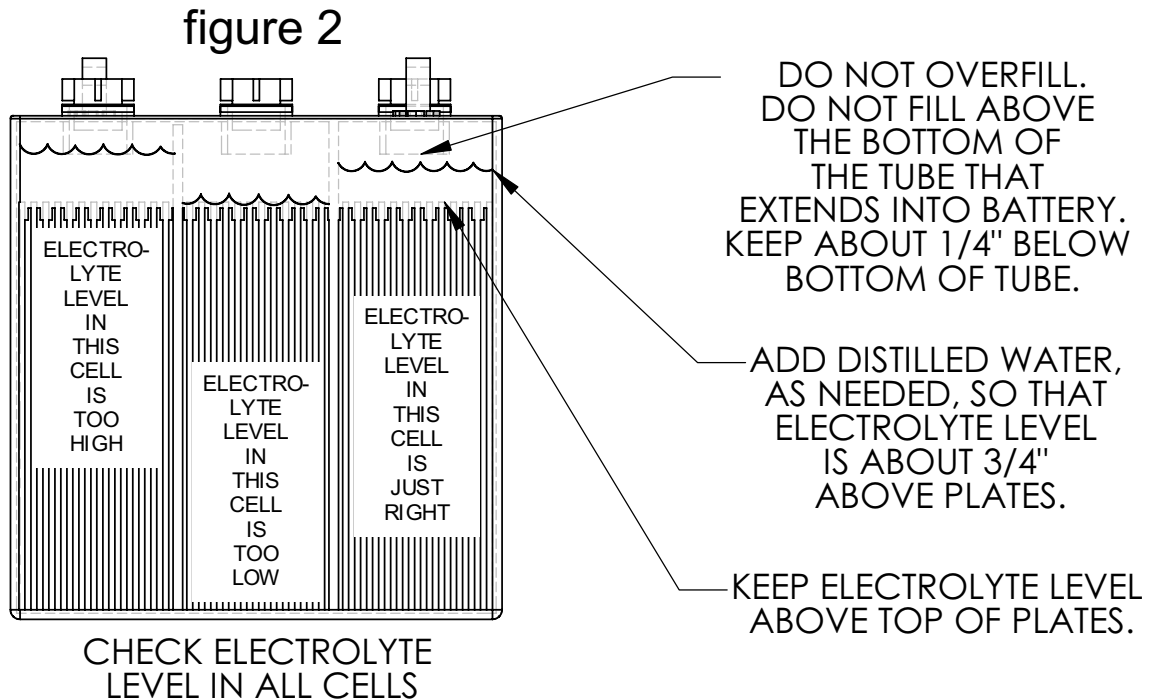

**!!! BATTERIES ARE DANGEROUS !!!**  
READ THE SAFETY INSTRUCTIONS  
IN THE FRONT OF THIS MANUAL  
FOR SPECIFIC WARNINGS

## IF YOU WOULD LIKE TO LEARN MORE ABOUT BATTERIES

THERE IS A VERY INFORMATIVE PUBLICATION AVAILABLE. IT COVERS SUBJECTS SUCH AS BATTERY TERMS AND HOW A BATTERY WORKS TO SPECIFIC GRAVITY TESTING WITH A HYDROMETER AND DIAGNOSIS OF BATTERY PROBLEMS.

YOU CAN OBTAIN A COPY OF THE "**BATTERY SERVICE MANUAL**" FROM

BATTERY COUNCIL INTERNATIONAL  
401 N. MICHIGAN AVENUE  
CHICAGO, IL 60611  
PHONE 312-644-6610

# PREVENTATIVE MAINTENANCE ITEMS

## Before starting work

- Inspect pads for wear. Replace if needed.
- Turn on brush motors and check battery indicator gauge to assure that there is enough charge to scrub floor.

## After you are finished using scrubber for the day

- Raise squeegee and leave up.
- Raise brushes and leave up.
- Drain and rinse recovery tank, including vacuum shut-off float. Wipe top of tank clean.
- Clean vacuum intake screen. A small wire brush works well for this.
- Wipe down recovery tank lid and lid gaskets.
- Drain and rinse solution tank (especially if using something other than a very mild scrubbing solution).
- Charge batteries, if needed. Remember batteries have a longer life if allowed to discharge sufficiently. Please read "Battery Maintenance" page.

## Weekly maintenance

- Check electrolyte level in batteries. See "Battery Maintenance" page for instructions.
- Clean and lubricate caster wheels and caster swivel. There are grease fittings to use a grease gun. Note: Main 10" wheels do not require lubricating. (They have sealed ball bearings that cannot be lubricated).
- Wipe surface of machine clean. A silicone product such as "Armor All" will make the plastic parts look really good.

## Monthly maintenance

- Clean battery connections and tops of batteries. See "Battery Maintenance" page for instructions.
- Inspect scrub brushes for wear (If you have scrub brushes).
- General visual inspection for problems.

## Semi-annual maintenance

- Inspect carbon brush wear in brush motors.
- Lubricate all pivot points with a light oil. Porous bushings will absorb some oil to distribute over time.
- Lubricate brush lift arm sliding surface with a heavy grease. This is located behind the back panel. Bearing grease may be used.

## As needed items

- Adjust squeegee tilt. See "Squeegee Information" page.
- Turn, flip, or replace squeegee blade for streak free pickup.
- Replace intake screen and intake screen gasket.

## PAD DRIVER AND AVAILABLE BRUSHES

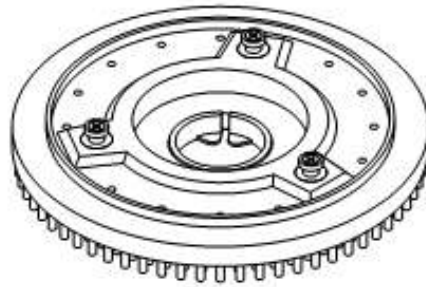

**PAD DRIVER**  
NEED 2 PER MACHINE

SKU	DESCRIPTION
E11235	16" pad driver (must be used with an appropriate pad)*

\* CONSULT YOUR JANITORIAL SUPPLIER FOR ADVISE  
ON THE PROPER PAD TO USE FOR YOUR APPLICATION.  
SCRUB AND STRIP PADS ARE COLOR CODED FROM  
LEAST AGGRESSIVE TO MOST AGGRESSIVE AS FOLLOWS:  
WHITE - RED - BLUE - GREEN - BROWN - BLACK

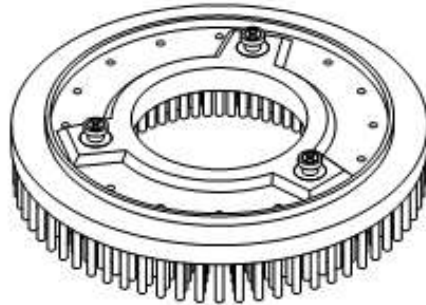

**BRUSH**  
NEED 2 PER MACHINE

PART NO.	DESCRIPTION	USES
E11236	Polyscrub	Very light scrubbing (replaces white pads)
E11237	Dynascrub	Light to medium scrubbing (replaces red pads)
E11238	Powerscrub	Medium to aggressive scrubbing (replaces blue or green pads)
E11239	Stratagrit	Very aggressive scrubbing or stripping (replaces brown or black pads)

A BRUSH WILL OUTLAST A PAD AT LEAST 100 TO 1

# SQUEEGEE INFORMATION AND ADJUSTMENTS

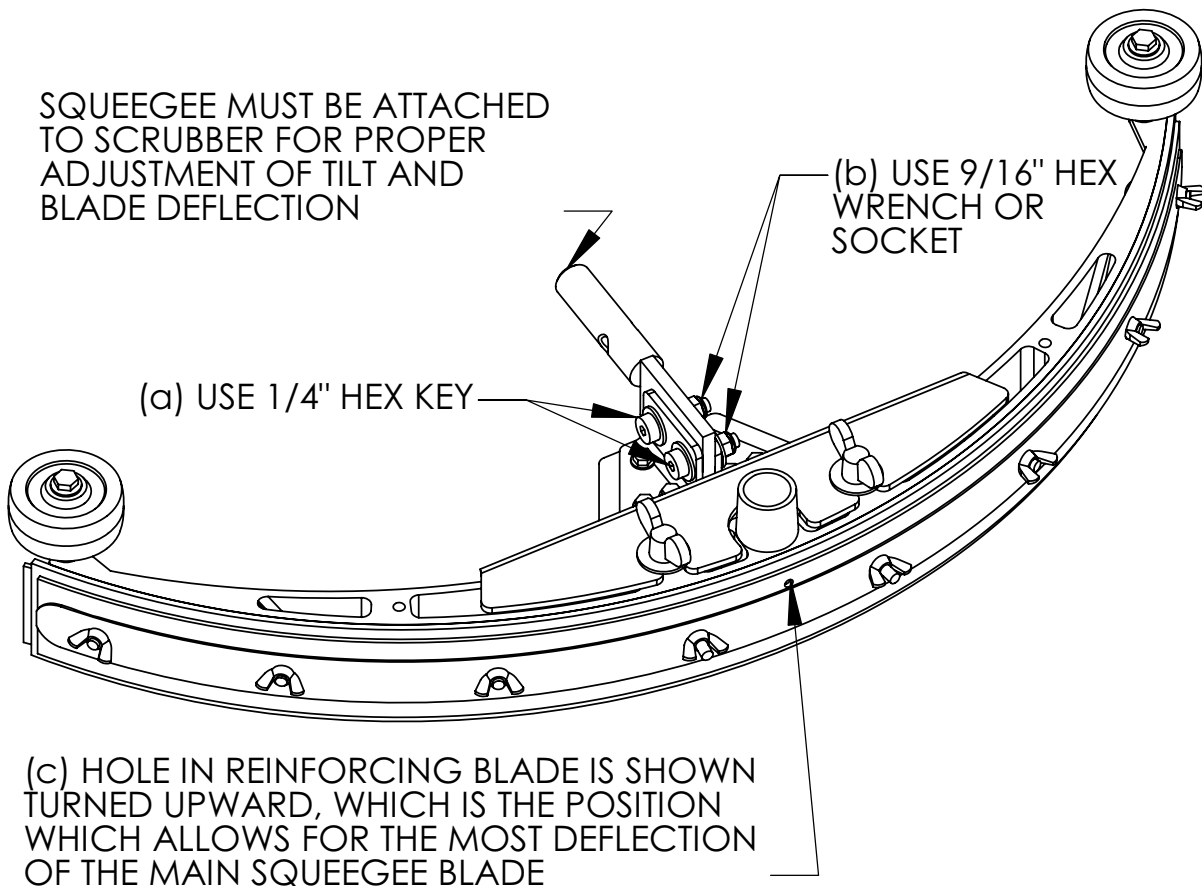

**Problem:** Squeegee is leaving streaks at the center or the ends.

**Cause:** Squeegee is not level. If it is not level, it will streak in the center or at the ends.

**Solution:** Make sure that the tips and the center of main squeegee blade are uniformly deflected and not leaving streaks. Adjust squeegee tilt as follows:

Step 1: Loosen (a) and (b)

Step 2: Tilt squeegee in direction needed for squeegee to deflect uniformly along entire length.

Step 3: Tighten (a) and (b) enough to hold temporarily.

Step 4: Move scrubber forward to check that deflection is uniform.

Step 5: If correct, tighten (a) and (b) as much as you can; or if not correct, start over at step 1.

**Problem:** Squeegee is leaving streaks not related to squeegee being level.

**Cause:** (1) Trash under main squeegee blade.

(2) Blade edge is worn or nicked

**Solution:** (1) Clear trash.

(2) Turn the blade. All four edges can be used. If all edges have been used, then replace the main squeegee blade.

**Problem:** Main squeegee blade is deflecting too much or too little.

**Cause:** Reinforcing blade is turned wrong for the floor conditions.

**Solution:** Holes on the reinforcing blade are offset. Blade can be flipped to put longer or shorter side toward floor. Longer side has a hole (c) at center. Facing the hole down makes the main blade stiffer and allows it to deflect less. Hole turned upward allows blade to deflect more.

# BRUSH OPERATION

HOW TO:  
RAISE BRUSHES,  
LOWER BRUSHES,  
ADD HEAVY PRESSURE  
TO BRUSHES, AND  
RELEASE PRESSURE  
FROM BRUSHES

FIGURE 1

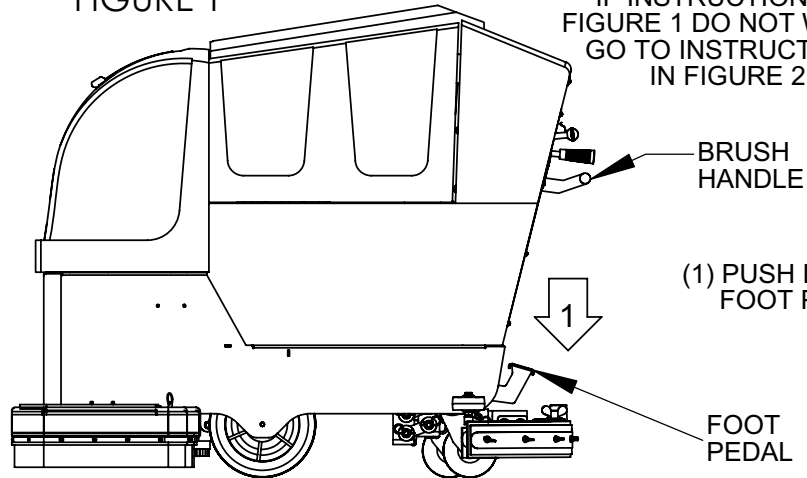

RAISE BRUSHES  
IF INSTRUCTIONS IN  
FIGURE 1 DO NOT WORK,  
GO TO INSTRUCTIONS  
IN FIGURE 2

(1) PUSH DOWN  
FOOT PEDAL

FIGURE 2

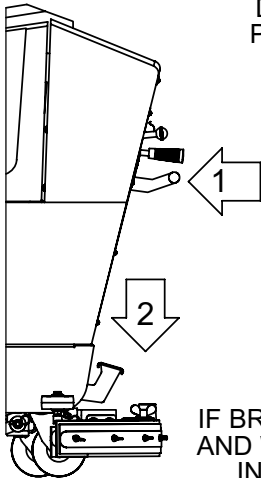

TO RAISE BRUSHES  
IF INSTRUCTIONS IN FIGURE 1  
DO NOT WORK, THERE ARE  
PROBABLY NO BRUSHES ON  
SCRUBBER AND THIS  
SHOULD RAISE BRUSHES.

- (1) PUSH IN  
HANDLE
- (2) PUSH DOWN  
FOOT PEDAL

IF BRUSHES ARE ON SCRUBBER  
AND WILL NOT RAISE, THEY ARE  
IN THE HEAVY PRESSURE  
POSITION, SO PROCEED TO  
FIGURE 5 TO RELEASE BRUSHES.

FIGURE 3

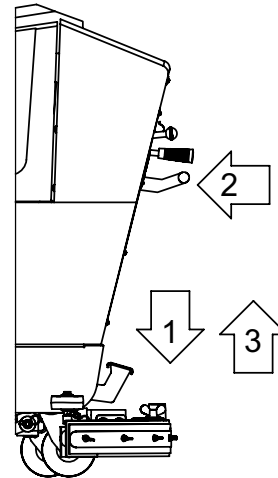

LOWER BRUSHES

- (1) PUSH DOWN  
FOOT PEDAL
- (2) PUSH IN  
HANDLE
- (3) RELEASE  
FOOT PEDAL  
SLOWLY

FIGURE 4

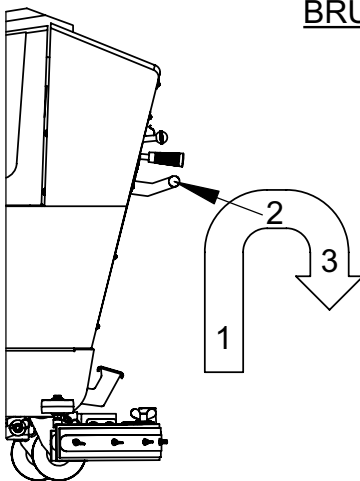

ADD HEAVY  
BRUSH PRESSURE

- (1) PULL UP  
HANDLE
- (2) PULL BACK  
HANDLE,  
WHILE STILL  
PULLING UP
- (3) LOWER  
HANDLE SLIGHTLY  
WHILE STILL  
PULLING BACK

FIGURE 5

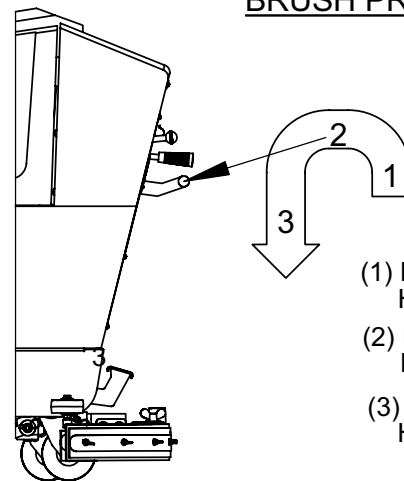

RELEASE HEAVY  
BRUSH PRESSURE

- (1) PULL UP  
HANDLE
- (2) PUSH IN  
HANDLE
- (3) LOWER  
HANDLE

# OPERATING TIPS AND MISCELLANEOUS INFORMATION

## FLOOR SCRUBBING TIP

- Double scrubbing can be a very effective way to clean a floor. This especially important before coating with finish, as you do not want to wax in any dirt.
  - To double scrub do the following:
    - Scrub the floor as normal, but leave the squeegee up and the vacuum off.
    - Scrub a few aisles ahead while letting the floor soak.
    - Then go back over what you have wet down, but this time with the squeegee down and the vacuum on. This will get the floor much cleaner than a single pass scrub.

**Note:** Do not double scrub where non-floor cleaning personnel will be walking, since the floor stays wet and is therefore hazardous.

## SQUEEGEE OPERATING TIPS

- The curved squeegee picks up solution very well if properly adjusted. The squeegee must be level to work well. If it is not level, it will streak in the center or at the ends. Make sure that the tips and the center are uniformly deflected and not leaving streaks. If squeegee is not level, then loosen the two bolts on squeegee bracket and squeegee will pivot forward and backward. Level squeegee and tighten bolts.
- If squeegee is properly adjusted and is leaving streaks, then there may be trash caught under the main squeegee blade. A little trick that will clear most trash is to (1) stop the scrubber, (2) lift the squeegee, (3) back up a little, (4) lower the squeegee, and then (5) resume scrubbing as usual. If this does not work, then the trash must be cleared by hand.
- See "Squeegee Information and Adjustments" page for more information.

## IF SCRUBBER IS USED FOR PICKING UP WAX AND STRIPPER

- The scrubber can be used to vacuum the emulsified wax and stripper from a floor strip. But, be aware that more upkeep will be required on the scrubber than if it were used only for scrubbing, since the wax and dirt will remain after the stripper evaporates. So, after using scrubber on a floor strip do the following.
  - Disconnect vacuum hose from squeegee and vacuum clean water through vacuum hose.
  - Rinse out recovery tank, including letting clean water run out dump hose.
  - Clean squeegee.
  - Clean top of recovery tank.
  - Clean recovery lid and gasket on recovery lid.
  - Drain solution tank and flush lines with clean water. (If you have stripper in the solution tank, you do not want it on the floor if the next job the scrubber is used on is just a scrub).
  - Wipe down anywhere where wax slop has gotten on scrubber.

## EXPOSING SCRUBBER TO FREEZING TEMPERTURES



- Do **NOT** leave scrubber in freezing temperatures
- If scrubber must be left or transported in freezing temperatures, then precautions must be taken. If an attempt is made to close (or open) the solution valve when it is frozen, the solution cable or solution valve will be damaged.
  - Drain Solution Tank and leave solution valve open.
  - Recovery Tank must also be drained.
  - Then after the scrubber is inside place to be used, do not yet attempt to shut the solution valve. You must first check to make sure that the solution valve is not frozen. Run hot water into solution tank. After water is running out the bottom of the machine (the brush area), then shut off solution valve (do not force the solution valve control handle). You can then fill solution tank and use the scrubber.

## DESCRIPTIONS OF VIEWS SHOWING PARTS ON SCRUBBER

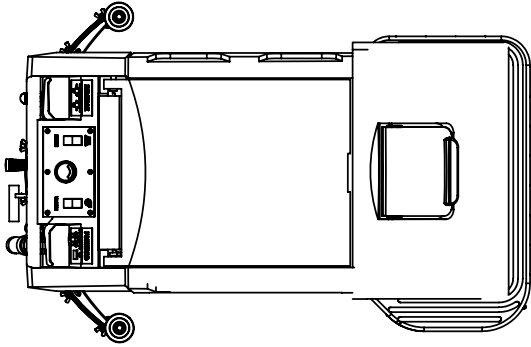

TOP VIEW

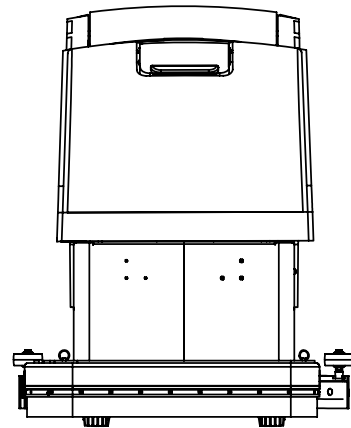

FRONT VIEW

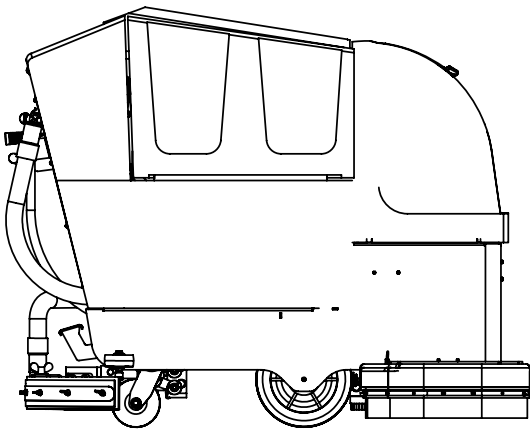

RIGHT VIEW

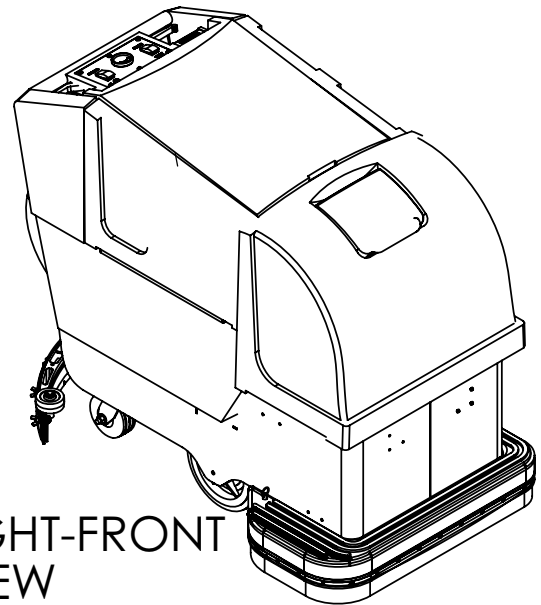

TOP-RIGHT-FRONT  
VIEW

IN THIS MANUAL, MANY OF THE PARTS IN THE DRAWINGS ARE SHOWN CORRECTLY ASSEMBLED, OR AT LEAST NEAR THE POSITIONS THEY ARE LOCATED ON THE SCRUBBER.

THIS METHOD WILL HELP TRACE A PROBLEM, FIND WHAT IS NEEDED TO CORRECT THE PROBLEM, AND THEN PROPERLY REASSEMBLE THE MACHINE .

THE ELECTRICAL LAYOUT HAS ALSO BEEN SIMPLIFIED, SO THAT PROBLEMS CAN BE EASILY TRACED AND REPAIRED.

# Operating Procedures

(See page 19 for guide to item numbers)

- Batteries need to be in the operating range (the green area) of the battery condition meter (item 2). Gauge will register battery condition when brush motors (Brush Motor Control Switch, item 6) are turned on. Turn off brush motors after battery condition is determined.
- Lift solution lid (item A) and add water and liquid cleaner to solution tank (item B). Consult cleaner instructions for proper ratio of cleaner and water (Note: the solution tank holds 24 gallons when full).
- Take scrubber to area to be cleaned
  - Traction Scrubber
    - Make sure that squeegee and brushes are off the floor.
    - Turn variable speed control knob (item 8) all the way counterclockwise.
    - Turn on traction switch (item 9).
    - Squeeze forward control lever (item 1) if scrubber needs to go forward and reverse control lever if scrubber needs to be moved backward.
    - Gradually increase variable speed control knob (item 8) until scrubber attains the needed speed.
    - Release lever to stop.
  - Brush Drive Scrubber
    - Lift squeegee and brushes off the floor.
    - Push scrubber to desired location.
- Lower brushes by depressing brush lift pedal (item 13) and then push in on brush lift and pressure lever (item 11), and gradually let brushes drop to contact with floor by slowly lift foot off brush lift pedal (item 13). (Note that the brushes can be lowered using only the brush lift and pressure lever (item 11)).
- Lower squeegee using the squeegee lift lever (item 18) and turn on vacuum using the vacuum motor control switch (item 7).
- Turn on solution by adjusting cleaning solution control lever (item 17) to desired flow rate (the flow rate can be adjusted as the need arises).
- Turn on brushes using the brush control switch (item 6) and immediately move scrubber forward.
  - Traction Scrubber – adjust speed as needed with the variable speed control knob (item 8).
  - Brush Drive Scrubber – push to desired speed. There is no need to keep the forward control lever depressed. The brush drive scrubber should move easily by pushing alone.

*Operating procedures are continued on the next page* 



# Operating Procedures

(continued)

- When you stop scrubbing an area.
  - Turn off brushes (brushes or pads can wear through the wax if left running in one place)
  - Turn off solution flow (cleaning solution control lever (item 17))
  - Turn off vacuum (vacuum motor control switch (item 7))
  - Turn off traction drive on traction drive model (traction on/off switch (item 9))
  
- Before taking scrubber back to storage area
  - Lift brushes
  - Lift squeegee
  
- To dump dirty water from recovery tank (item C)
  - Lift recovery dump hose (item 12) with plug for recovery dump hose (item 10) from hooks.
  - Hold end of hose so that the dirty solution will flow into the appropriate place (such as a drain) when plug is removed.
  - Loosen T-handle on plug for recovery dump hose (item 10) and remove plug from hose. Dirty solution will flow from tank. (Note: do not completely unscrew T-handle from plug).
  - Replace plug and tighten. Hang hose back on hooks.
  
- Machine storage for the day
  - Brushes in up position
  - Squeegee in up position
  - Recovery tank emptied (Note: it is best to occasionally rinse it out with clean water).
  - Solution tank emptied (especially if machine is to be left for longer than a day).
  - Turn off all switches. (Note: if traction on/off switch is left on for more than 20 minutes without the machine moving, then the traction control electronics will automatically power down. To reset them, simply turn the traction on/off switch off and then back on).

# MAIN SCRUBBER PARTS

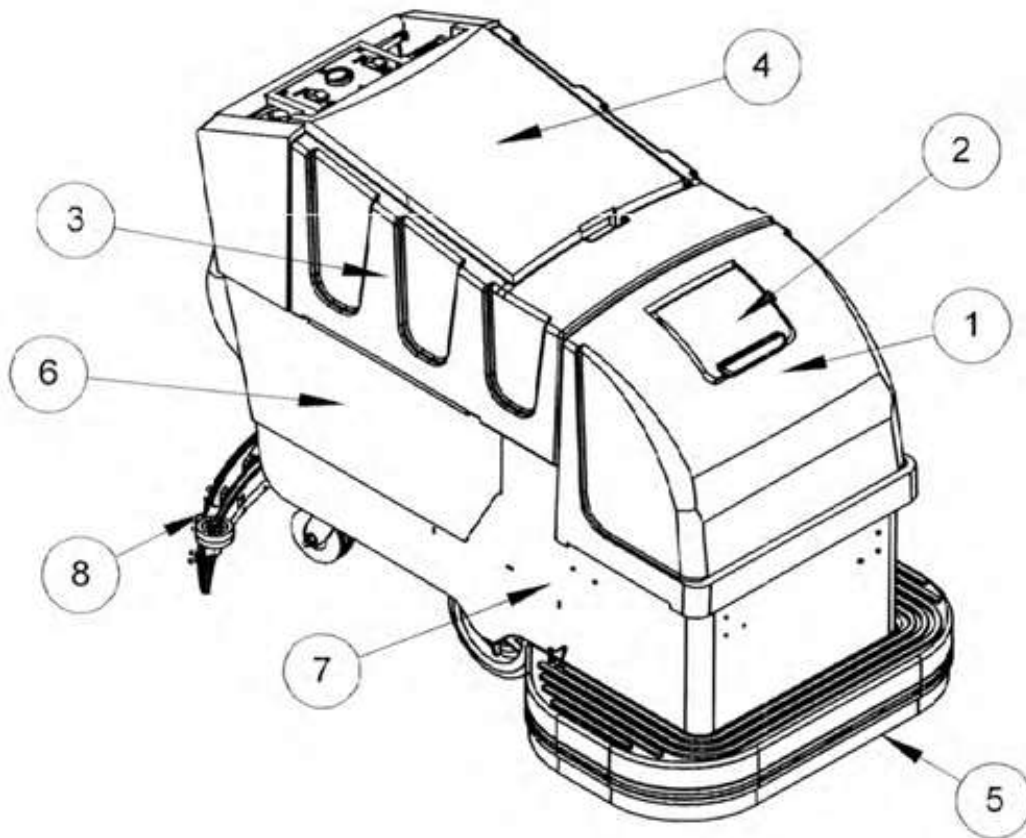

ITEM	SKU	Description
1	E11729	Solution Tank (GRAY)
2	E11728	SOLUTION TANK LID (BLACK)
3	E11233	LARGE RECOVERY TANK
4	E11727	RECOVERY TANK LID (BLACK)
5	E11232	LARGE SKIRT
6	E11726	BASE (BLACK)
7	AS321121	Main Frame N/A
8	PE5002	Squeegee assembly AS3200

# SCRUBBER CONTROLS

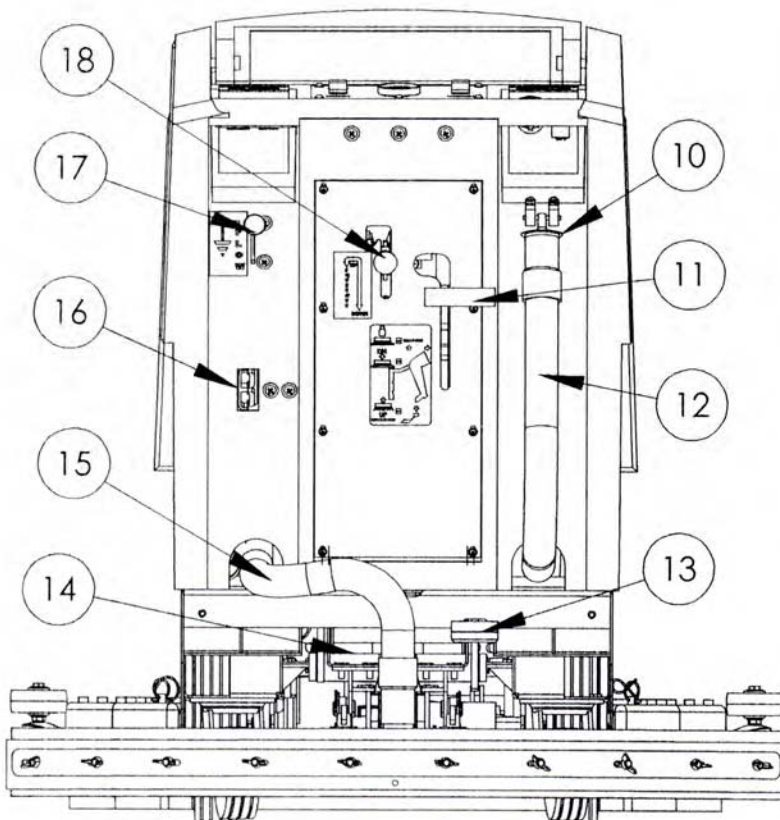
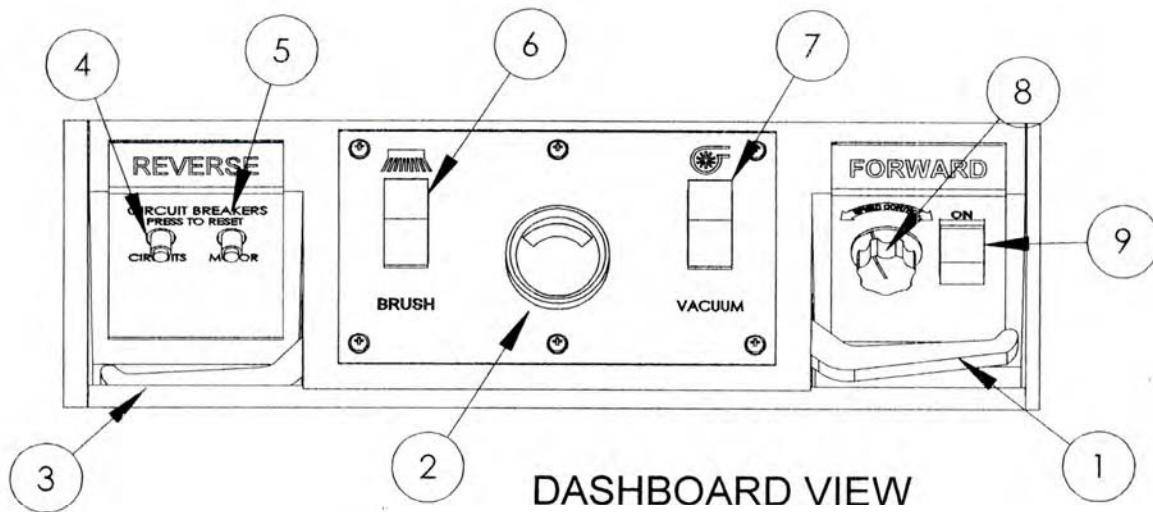

- 1) Forward Control Lever
- 2) Battery Condition Meter
- 3) Reverse Control Lever
- 4) Circuit Breaker for Vacuum
- 5) Circuit Breaker for Brush Motors
- 6) Brush Motor Control Switch
- 7) Vacuum Motor Control Switch
- 8) Variable Speed Control Knob
- 9) Traction on/off switch
- 10) Plug for Recovery Dump Hose
- 11) Brush lift and Pressure Lever
- 12) Recovery Dump Hose
- 13) Brush Lift Pedal
- 14) Drain Hose for Battery Tray
- 15) Vacuum Recovery Hose
- 16) Charging Plug for 36 Volt  
Charger
- 17) Cleaning Solution Control Lever
- 18) Squeegee Lift Lever

# REAR VIEW OF SCRUBBER

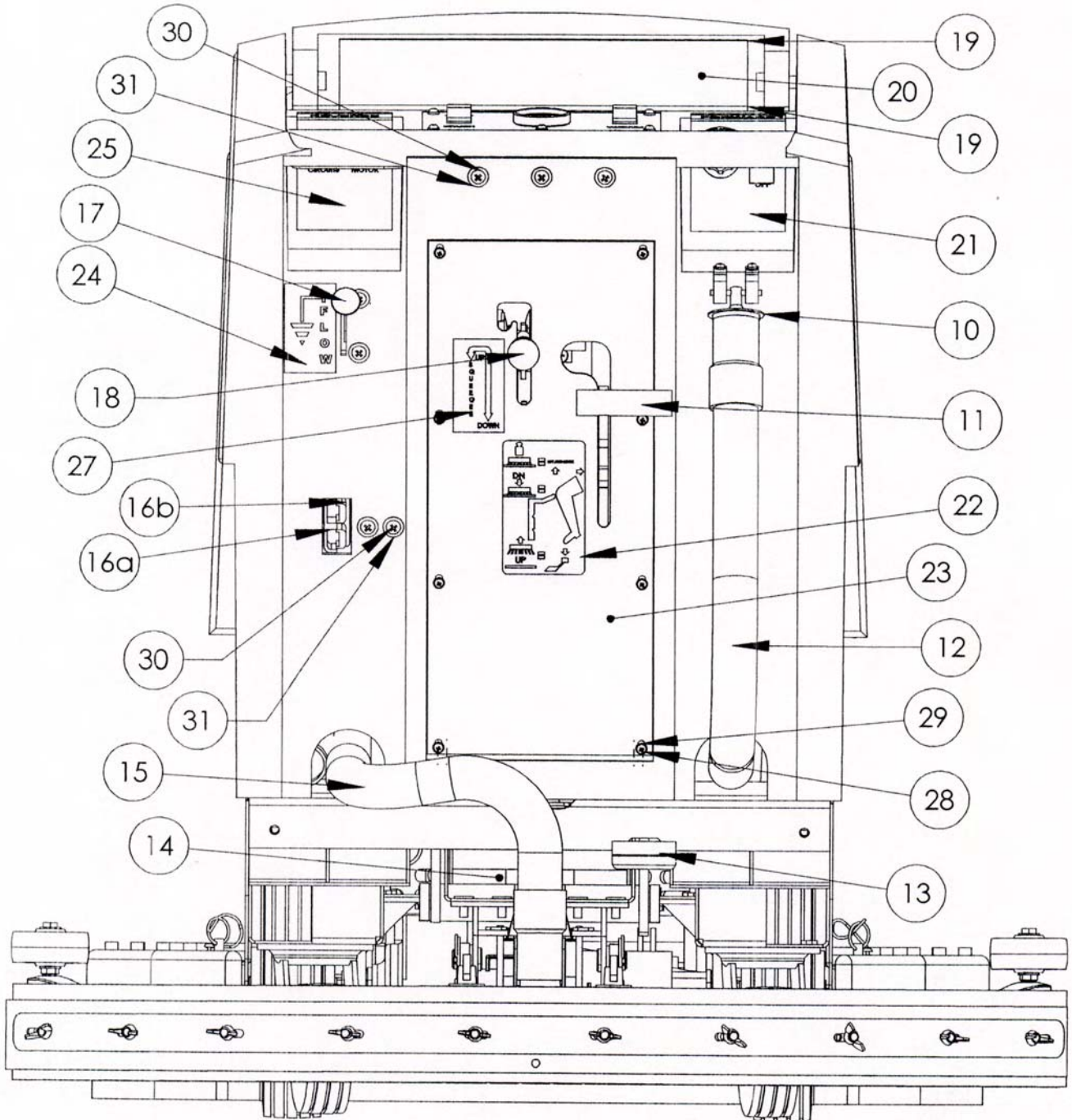

PARTS LIST IS ON NEXT PAGE →

# DASHBOARD LAYOUT AND PARTS FOR DASHBOARD AND PARTS FROM REAR VIEW OF SCRUBBER

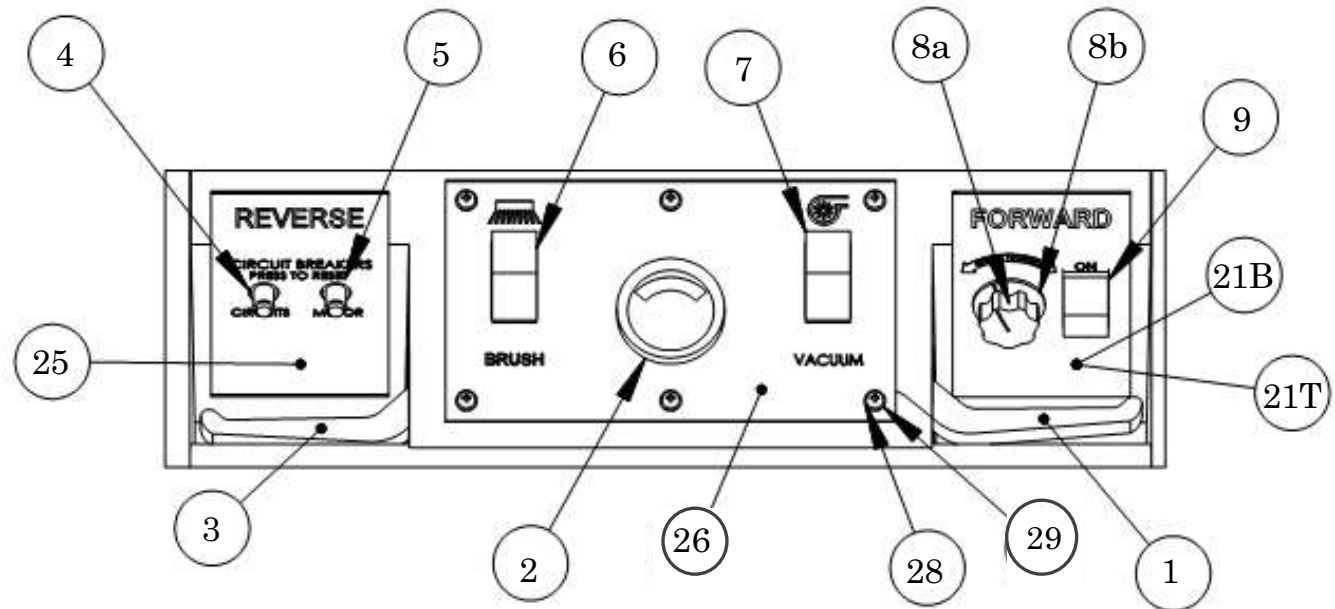

ITEM	QTY.	PART NO.	DESCRIPTION
1	1	E11521	RIGHT HANDLE LEVER
2	1	E10865	36 VOLT SYSTEM GAUGE
3	1	E11520	LEFT HANDLE LEVER
4	1	E11527	CIRCUIT BREAKER - 30AMP
5	1	E11528	CIRCUIT BREAKER - 70 AMP
6, 7, 9	3	E11529	ROCKER SWITCH
8a	1	E11738	CLAROSTAT ROTARY CONTROL
8b	1	E11739	SPEED CONTROL KNOB
10	1	E11105	DRAIN PLUG 1 1/2 (#52003)
11	1	E12104	BRUSH LIFT HANDLE
12	1	>> see	see "Vacuum System and Solution System" pages
13	1	E12110	BRUSH LIFT HANDLE - PEDAL
14	1	>> see	See "Vacuum System and Solution System" pages
15	1	>> see	See "Vacuum System and Solution System" pages
16a	1	E10878	Connector, SB175, Gray, #2, w/ Lugs
16b	1	E11889	BRACKET FOR ANDERSON PLUG
17	1	E11217	THROTTLE/ SOLUTION CABLE (for AS3200)
18	1	>> see	See "Brush Lift, Motor Mount, and Squeegee Lift" pages
19	1	E11515	LID FLAP .062" DIA.SHEET
20	2	E11879	FLAP RETAINER
21B	1	AS26/3	Forward Decal (for Brush Drive Scrubber)
21T	1	E11637	Decal, Speed Control
22	1	E11636	BRUSH POSITION DECAL
23	1	E11878	BACK PANEL
24	1	AS321532	Flow Label NLA
25	1	E11634	REVERSE DECAL
26	1	E11632	DASHBOARD
27	1	E11635	Decal, Squeegee
28	14	E11143	10-24 x 3/4 UNC PAN HD PHIL
29	14	E11508	#10 NYLON WASHER
30	7	E11833	1/4-20x3/4 PHMS PHILLIPS - BLK
31	7	E11834	1/4 FLAT WASHER - BLACK

# SOLUTION TANK AND SOLUTION TANK LID ASSEMBLY AND PARTS LIST

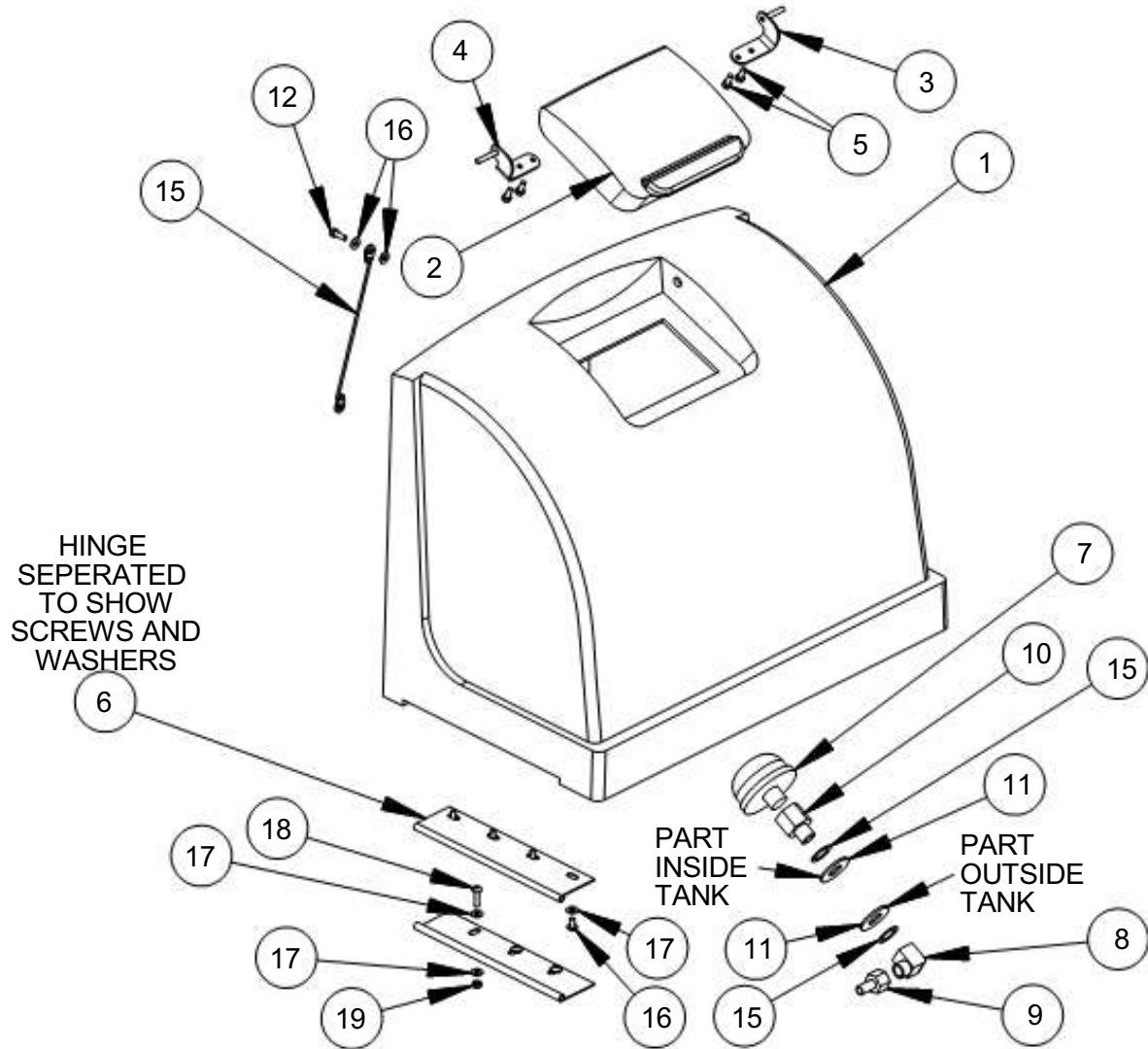

ITEM	QTY.	PART NO.	DESCRIPTION
1	1	E1172900	Solution Tank (GRAY)
2	1	E1172800	SOLUTION TANK LID (BLACK)
3	1	E1210200	HINGE - SOLUTION LID - LEFT
4	1	E1210100	HINGE - SOLUTION LID - RIGHT
5	4	E8106400	Bolt 1/4-20x3/4 hex gr 5
6	1	E1173200	HINGE - SOLUTION TANK
7	1	E1110100	SOLUTION STRAINER
8	1	AS26/32060	Hose fitting
9	1	AS26/32054	Hose fitting
10	1	AS26/32063	Hose fitting
11	2	E1110700	Gasket, 1/2" BLK Neoprene
12	1	PE50058	Restraining Cable for Solution Tank
13	1	E8106400	Bolt 1/4-20x3/4 hex gr 5
14	2	E8171300	Washer 1/4 in flat
15	2	E1112900	Spacing Washer (#730-009)
16	4	E1112200	1/4-20 x .5 SS PHMS screw
17	10	E8171300	Washer 1/4 in flat
18	3	E8357000	Screw 1/4" - 20 x 1"
19	3	AS26/32241	Nyloc nut

# RECOVERY TANK ASSEMBLY AND PARTS LIST

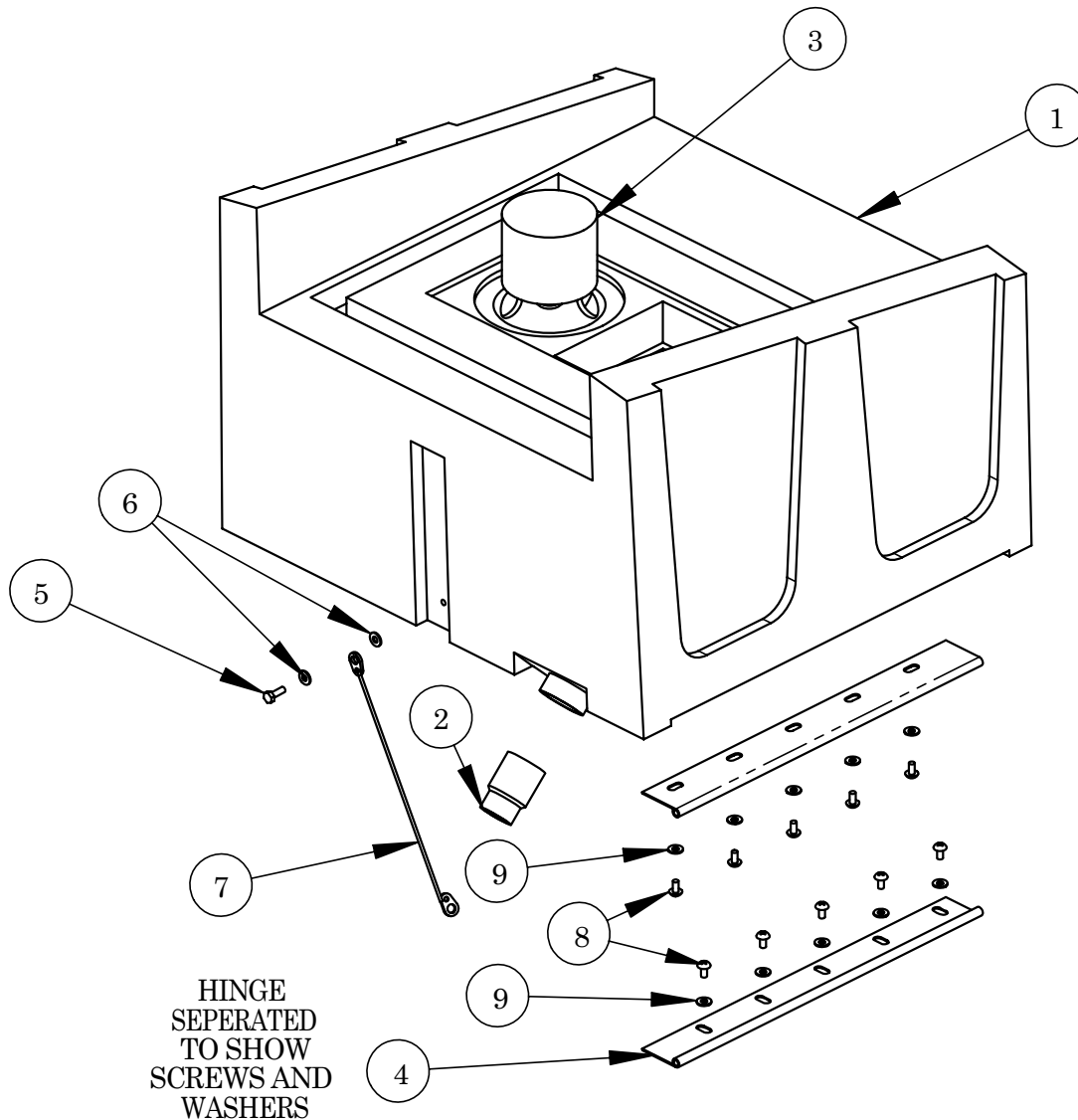

ITEM	SKU	Description	QTY
1	E11754	RECOVERY TANK (GRANITE)	1
2	E81294	Hose Barb 1 1/2 in.	1
3	AS26/3	Foam Float assembly	1
4	E11731	HINGE - RECOVERY TANK	1
5	E81064	Bolt 1/4-20x3/4 hex gr 5	1
6	E81713	Washer 1/4 in flat	2
7	PE5005	Cable for recovery tank ASM	1
8	E11122	1/4-20 x .5 SS PHMS screw	5
9	E81713	Washer 1/4 in flat	10

# RECOVERY LID ASSEMBLY

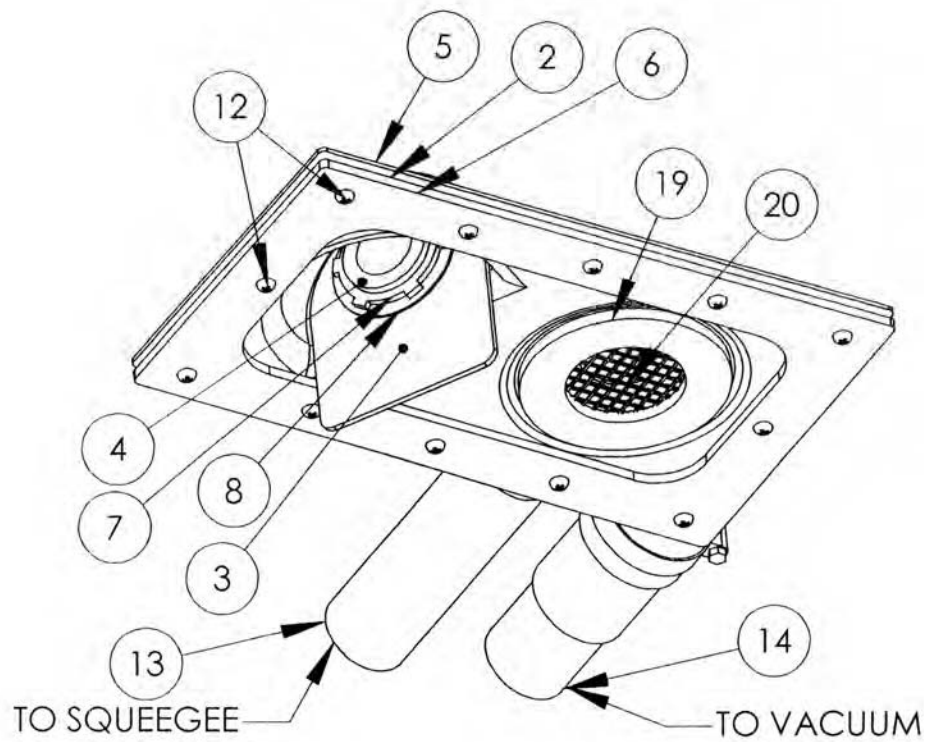
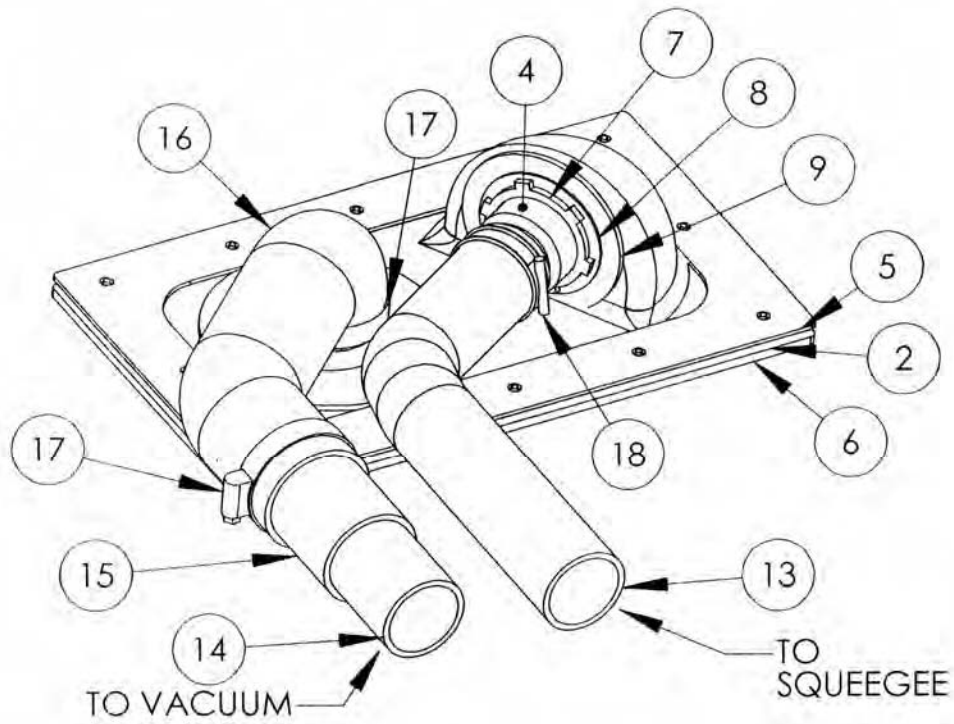



# RECOVERY LID ASSEMBLY AND PARTS

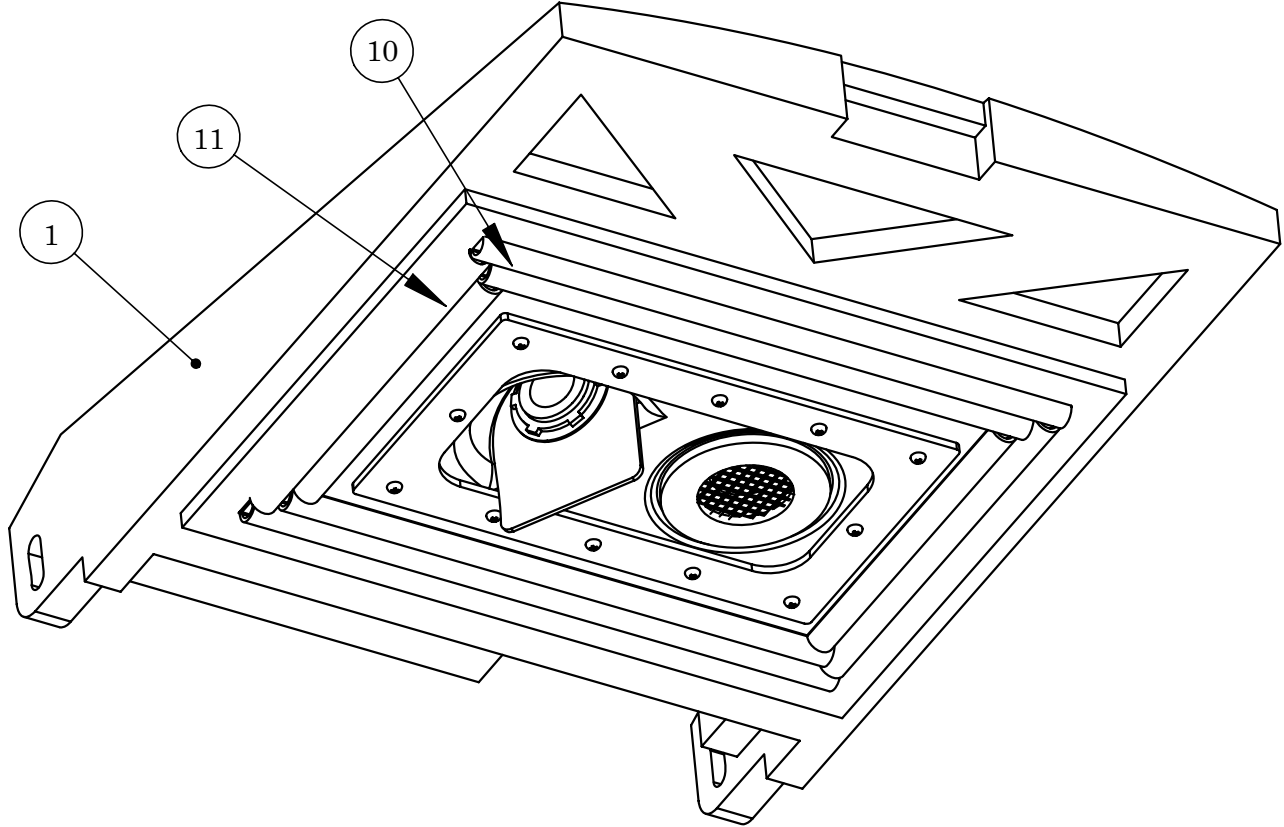

ITEM	SKU	DESCRIPTION	QTY
1	E11727	RECOVERY TANK LID (BLACK)	1
2	E11868	VACUUM INTAKE	1
3	E11496	RUBBER VAC. INTAKE FLAP	1
4	E81294	Hose Barb 1 1/2 in.	1
5	E11518	3/32" 50 DURO NEOPRENE	1
6	E11895	RECOVERY LID PLATE	1
7	E81518	Nut, conduit 1 1/2 in.	2
8	E11130	Washer	2
9	E11108	1 1/2"BLACK NEOPRENE GASKET	1
10	E11929	Long Recovery Lid Gasket (16")	2
11	E11930	Short Recovery Lid Gasket (10")	2
12	E83570	Screw 1/4" - 20 x 1"	12
13	E11399	Vac hose 1.5" x 54"	1
14	PE5005	Vac Hose (Squeegee to recovery lid)	1
15	E11526	1 1/2"-1 3/4 CONNECT.HOSE CUFF	1
16	E11921	2" Vac Hose (7" Long)	1
17	E11535	HOSE CLAMP 2"	2
18	E11887	1.5" WIRE HOSE CLAMP	1
19	E11514	GASKET FOR VAC INTAKE SCREEN	1
20	E10775	2 9/16"DIA.STAINLESS STEEL DIS	1

# SPLASH SKIRT ASSEMBLY AND PARTS LIST

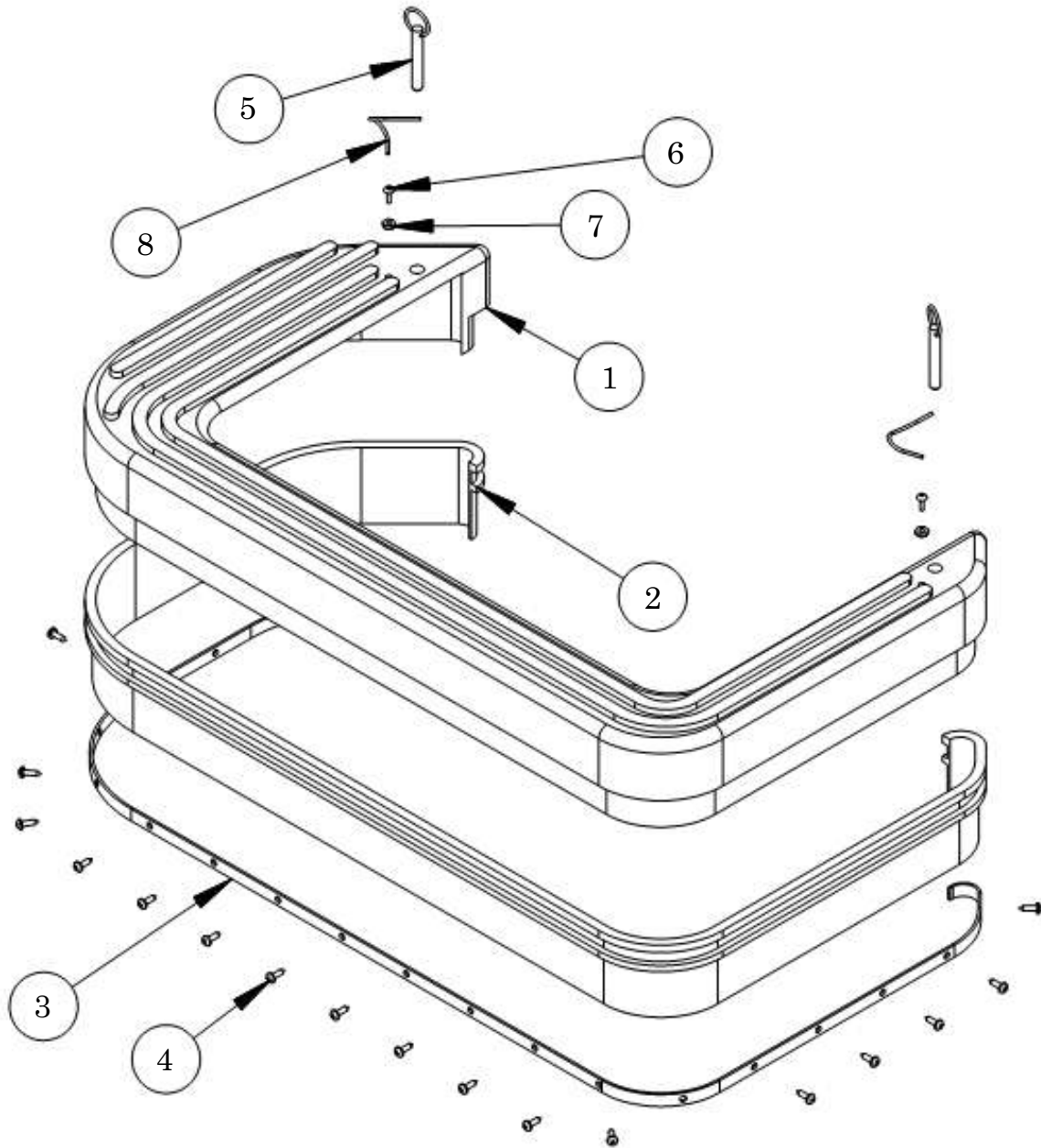

ITEM	SKU	DESCRIPTION	QTY
1	E11232	LARGE SKIRT	1
2	E11203	Rubber splash skirt 76"	1
3	E10516	SKIRT RETAINER FOR 32"	2
4	E11321	#10 x 5/8 PAN HEAD PHILLIPS	21
5	E10774	SINGLE BALL RING (1.5) GRIP	2
6	E11118	10-32 x .75 Unslotted Screw	2
7	E11095	10-24 NYLOC NUT	2
8	E87986	Pin, Detent 5/16" OD x 3/4" L, Zinc	2

# SQUEEGEE MOUNT ASSEMBLY AND PARTS LIST

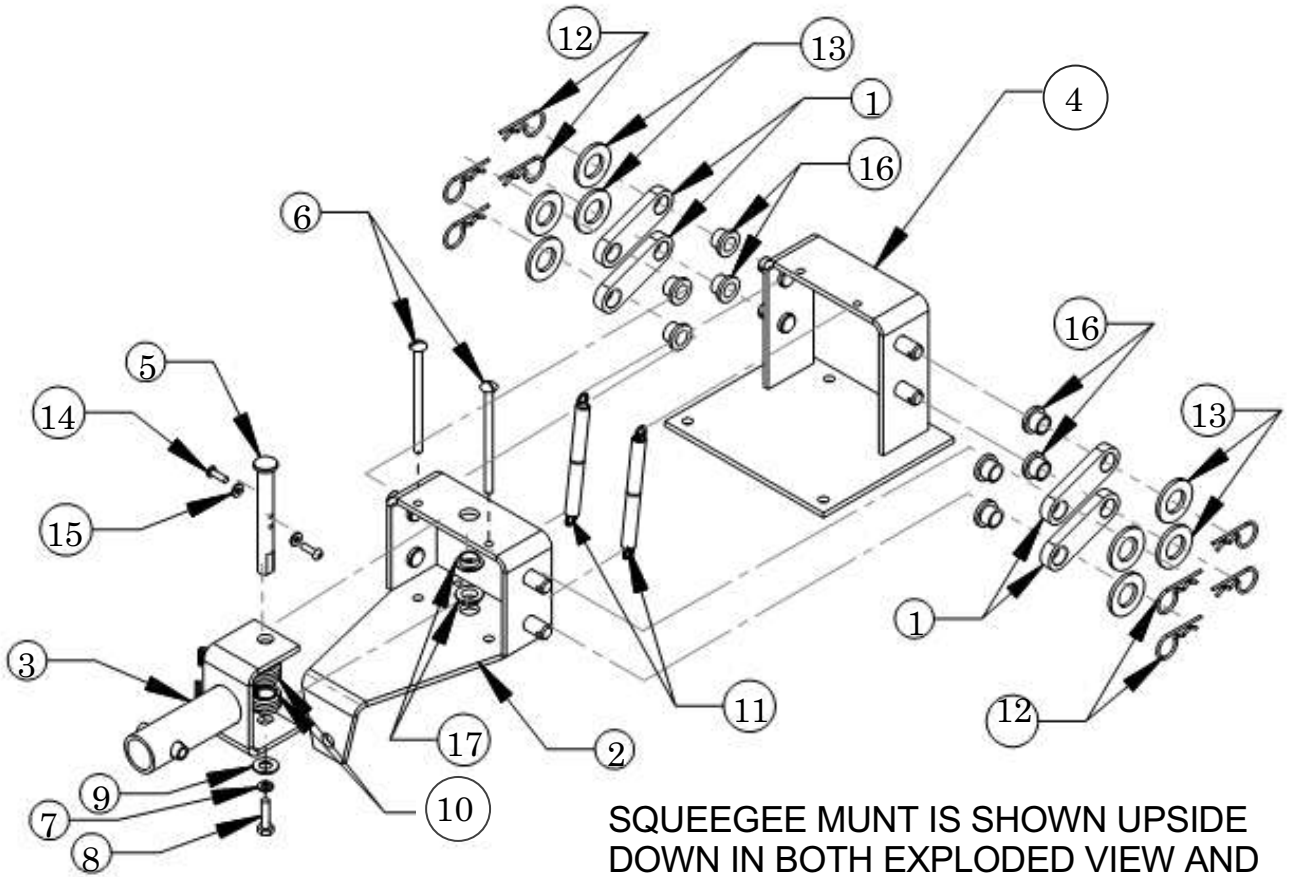

SQUEEGEE MOUNT IS SHOWN UPSIDE DOWN IN BOTH EXPLODED VIEW AND ASSEMBLED VIEW. THE BEST WAY TO WORK ON IT IS TO REMOVE IT FROM THE SCRUBBER AND TURN IT UPSIDE DOWN.

ITEM	SKU	DESCRIPTION	QTY
1	E12105	LINKAGE BAR	4
2	E12114	SQUEEGEE MOUNT HOUSING	1
3	E11894	SQUEEGEE MOUNT YOKE	1
4	E12112	SQUEEGEE MOUNT BRACKET	1
5	E11736	TORSION PIN	1
6	E11713	1/4-20x4" ROUND HD MS	2
7	E81078	Washer, Lock 1/4 in. Split	1
8	E81064	Bolt 1/4-20x3/4 hex gr 5	1
9	E81713	Washer 1/4 in flat	1
10	E11741	TORSION SPRING	2
11	E11566	SQUEEGEE LIFT HANDLE SPRING	2
12	E11719	Hairpin Cotter,	8
13	E12407	1/2 SAE FLAT WASHER GR8 PKG	8
14	E11143	10-24 x 3/4 UNC PAN HD PHIL	2
15	E11508	#10 NYLON WASHER	2
16	E11559	.502x.628x.500 LONG BUSHING	8
17	E11561	.502x.627 BUSHING	2

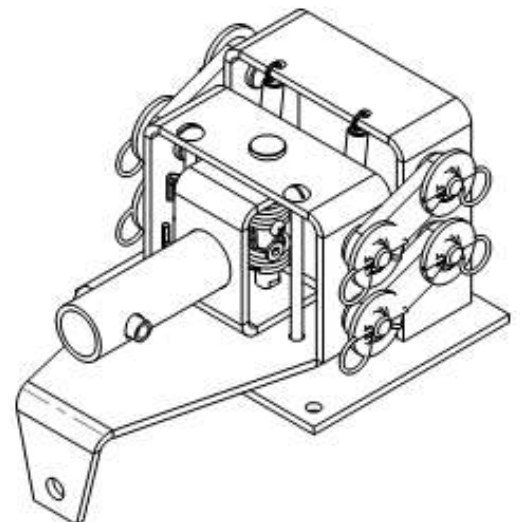

# SQUEEGEE ASSEMBLY FOR 26" SCRUBBER

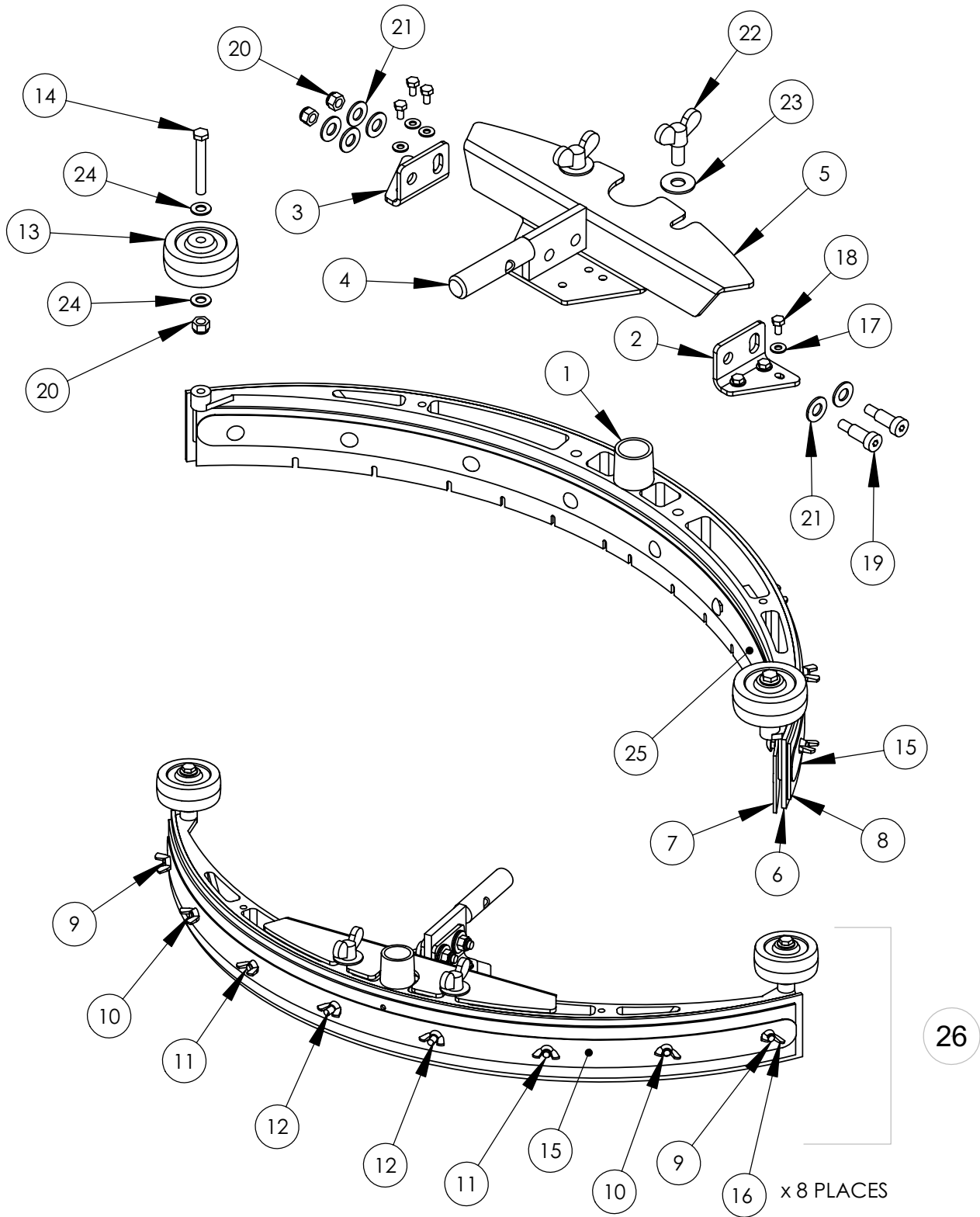

## SQUEEGEE ASSEMBLY PARTS LIST

ITEM	PART #	DESCRIPTION	QTY.
1	E10870	32" SQUEEGEE CASTING	1
2	E12108	LEFT ADJUSTMENT BRACKET	1
3	E12109	RIGHT ADJUSTMENT BRACKET	1
4	E11892	YOKE BAR FOR SQUEEGEE	1
5	E11893	MAIN SQUEEGEE PLATE	1
6	E10866	Blade, Squeegee Gum Rubber	1
7	E10869	Front Notched Squeegee Blade	1
8	E10867	Reinforcing Squeegee Blade	1
9	E11042	5/16-18X1.50 BOLT,CARR SS	2
10	E11043	5/16-18X2.00 BOLT,CARR SS	2
11	E11044	5/16-18X2.50 BOLT-CARR SS	2
12	E11045	5/16-18X3.00 BOLT-CARR SS	2
13	E11630	HA325SR-3/8 WHEEL	2
14	E11715	3/8-16x2.75 BOLT-HH	2
15	E10515	SQUEEGEE REAR BLADE STRAP	1
16	E11717	5/16 WINGNUT	8
17	E81713	Washer 1/4 in flat	6
18	E81064	Bolt 1/4-20x3/4 hex gr 5	6
19	E10010	1/2X1 SOC SHOULDER SCREW	2
20	E11146	3/8-16 UNC ELASTIC LOCKNUT	2
21	E11501	Washer, 7/16" USS, Zinc	6
22	E11084	1/2-13 x 1.00 Wing Bolt, Zinc	2
23	E11131	1/2 BRASS FLAT WASHER	2
24	E11136	3/8 SAE FLAT WASHER	4
25	E10511	SQUEEGEE FRONT BLADE STRAP	1
26	PE50024	Squeegee assembly AS3200	1
*	E11182	3/8X 2.25 CLEVIS PIN	1
*	E11719	Hairpin Cotter	1

BRUSH LIFT, MOTOR MOUNT,  
AND SQUEEGEE LIFT  
EXPLODED VIEW

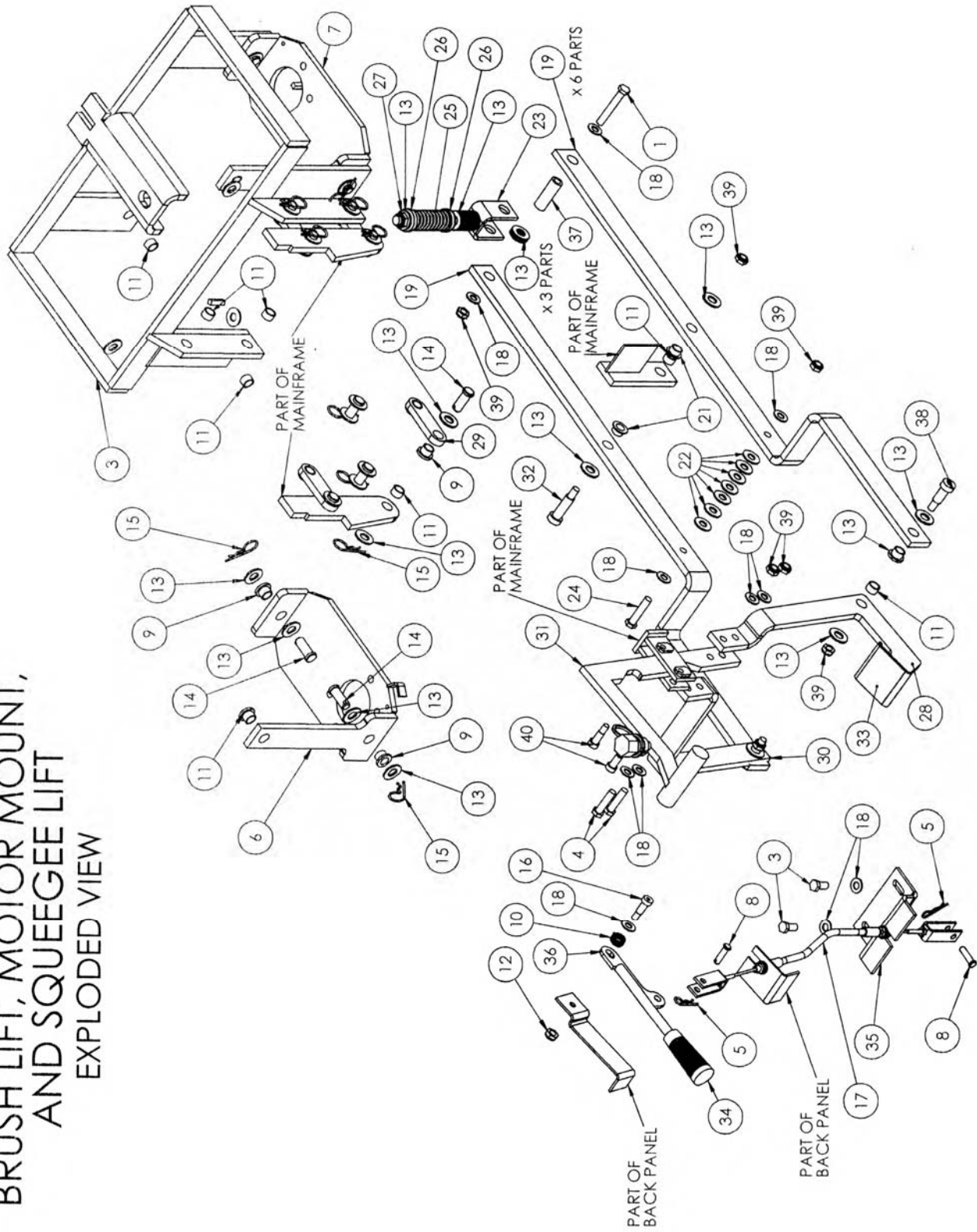

# BRUSH LIFT, MOTOR MOUNT, AND SQUEEGEE LIFT

## ASSEMBLED VIEW AND PARTS LIST

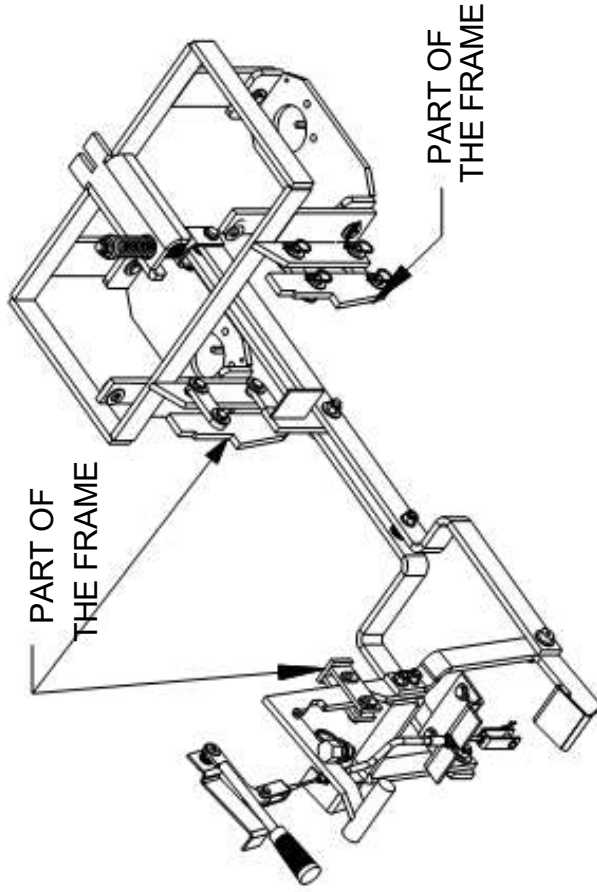

- 31 -

ITEM	SKU	Description	QTY
16	E11080	SHOULDER SCREW	3
17	E11558	LIFT CABLE	1
18	E11136	3/8 SAE FLAT WASHER	11
19	NLA	BRUSH LIFT ARM, LH	1
20	NLA	BRUSH LIFT ARM -RH	1
21	AS26/32654	#N/A	2
22	AS26/32283	#N/A	7
23	AS26/321139	#N/A	1
24	E11052	3/8-16X1.75#5 BOLT HH	1
25	E11231	BRUSH SPRING	1
26	E11104	CENTERING WASHER	2
27	E12410	1/2" LOCK NUT	1
28	E12110	BRUSH LIFT - PEDAL	1
29	E12105	LINKAGE BAR	4
30	E12111	BRUSH LIFT - BRACE	1
31	E12104	BRUSH LIFT HANDLE	1
32	E11079	SHOULDER SCREW	1
33	AS26/32986	#N/A	1
34	E10778	LEVER HAND GRIP	1
35	E12103	LIFT CABLE BRACKET	1
36	E11891	SQUEEGEE LIFT ARM	1
37	E11737	YOKE BUSHING	1
38	E10010	SHOULDER SCREW	2
39	E11146	ELASTIC LOCKNUT	7
40	E11080	SHOULDER SCREW	2

ITEM	SKU	Description	QTY
1	E11054	3/8-16X2.50#5 BOLT HH	1
2	E10514	MOTOR FRAME	1
3	E81080	Bolt 3/8-16x3/4	2
4	E11716	3/8-16x1.5 BOLT - HH	2
5	E11718	#1 HAIRPIN COTTER	2
6	E12106	MOTOR MOUNT, L.H.	2
7	E12107	MOTOR MOUNT - R.H.	2
8	E11725	5/16x1-1/8 CLEVIS PIN	2
9	E11559	LONG BUSHING	16
10	E11566	LIFT HANDLE SPRING	1
11	E11560	.501x.628 BUSHING	15
12	E81063	Nut, 5/16" - 18, Nylon Lock	1
13	E12407	1/2 SAE FLAT WASHER GR8 PKG	50
14	E11179	1/2X1.25 CLEVIS PIN	12
15	E11719	Hairpin Cotter,	12

# MOTOR FRAME AND MOTOR MOUNT

