



E86015-00



FOREMAN™ AS26B

26" Automatic Scrubber



**Operator's Manual
Parts Schematic**



Receiving the machine

Immediately check, when receiving the machine, that all the material indicated on delivery documents has been received and also that the machine has not been damaged in transit. If it has been damaged, this damage must be immediately reported to the shipper and also to our customer service department. Only acting promptly in this manner will make it possible to receive missing material and to be compensated for damage.

Identification plate

Foreword

This is a floor scrubbing machine that is able to clean any type of floor by using the mechanical action of the rotating brush and the chemical action of a water-detergent solution. As it moves forward it also gathers up the dirt removed and the detergent solution that has not been absorbed by the floor.

The machine must only be used for this function. Even the best machines will only operate efficiently and work with profit if they are used properly and kept in perfect operating order. Read this instruction booklet carefully and consult it every time problems arise with machine operation. Remember that, if necessary, our service organization, in collaboration with our dealers, is always available for helpful hints or direct intervention.

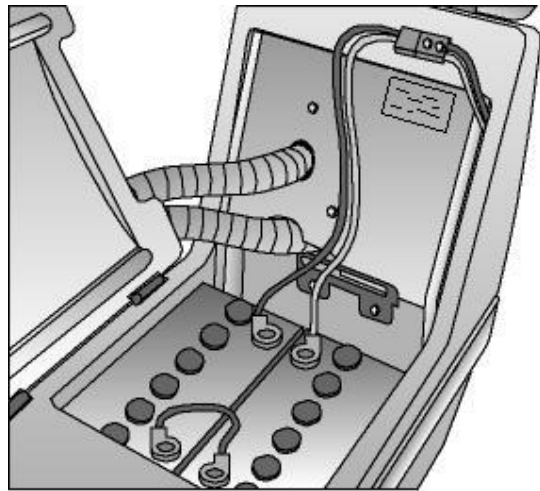



SYMBOLS USED ON THE MACHINE

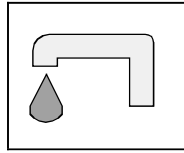

Cock symbol
Used to indicate the cock opening solenoid valve switch

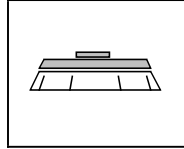

Brush symbol
Used to indicate the main/brush motor switch

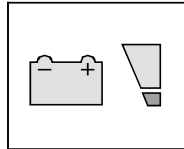

Battery charge level symbol.

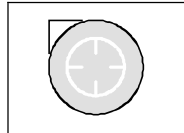

Aspiration motor symbol.
Indicates the aspiration motor switch.

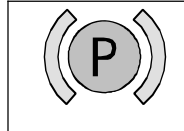

Brake symbol.
Indicates the hand brake engaged signal lamp. Used over the emergency brake lever.

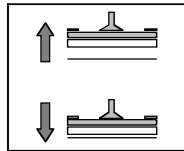

Squeegee lift/lower symbol. Indicates the squeegee lift lever.

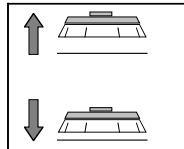

Brush base lift/lower symbol. Indicates the base lift lever.



Brake symbol.
Indicates the parking brake disengaged position.
MODIFICARE SIMBOLO

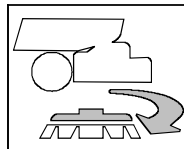

Automatic brush uncoupling symbol. Indicates the switch for automatic removal of brush.

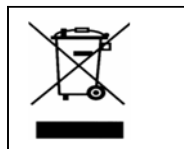

This symbol [the crossed-out wheeled bin/PICTURE] means that the product should be brought to the return and/or separate collection systems available to end-users, when the product has reached the end of its lifetime. This symbol applies only to the countries within the EEA (*).
(*) EEA = European Economic Area, which comprises the EU Member States plus Norway, Iceland and Liechtenstein.



GENERAL RULES OF SECURITY

The rules below have to be followed carefully in order to avoid damages to the operator and to the machine.

- Read the labels carefully on the machine. Do not cover them for any reason and replace them immediately if damaged
- The machine must be used exclusively by authorized staff that has been instructed for its use
- During the working of the machine, pay attention to other people and especially to the children
- Do not mix different detergents, avoiding harmful odours
- Do not place any liquid containers onto the machine
- The storage temperature has to be between - 25° C and + 55° C
- Operating conditions: room temperature between 0°C and 40°C with respective humidity between 30 and 95%
- Do not use the machine in explosive atmosphere
- Do not use the machine as a means of transport
- Do not use acid solutions which could damage the machine and/or the persons
- Avoid working with the brush when the machine stands still, in order to prevent floor damages
- Do not vacuum inflammable liquids
- This appliance is not suitable for picking up hazardous dust
- In case of fire, use a powder extinguisher. Do not use water
- Do not strike shelvings or scaffoldings, where there is danger of falling objects
- Adapt the utilization speed to the adhesion conditions
- ATTENTION! Do not use the machine on areas having a higher gradient than the one stated on the number plate
- When the machine is in parking position, take off the key and insert the parking brake
- The machine has to carry out simultaneously the operations of washing and drying. Different operations have to be carried out in areas which are not permitted for the passage of non employed staff. Signal the areas of moist floors with suitable signs
- If the machine does not work properly, check by conducting simple maintenance procedures. Otherwise, it is better to ask for **FIMAP** technical service
- Where parts are required, ask for ORIGINAL spare parts to an agent and/or to an authorized **FIMAP** dealer
- Use only original **FIMAP** brushes indicated in the paragraph "CHOICE AND USE OF BRUSHES"
- In case of danger act immediately upon the emergency brake
- For any cleaning and maintenance operation take off the power supply from the machine
- Do not take off the pieces which require the use of tools to be removed
- To restore all the connections electrical workers after whichever maintenance operation
- Do not wash the machine with direct water jets or with high water pressure nor with corrosive material
- Every 200 working hours have a machine check through a **FIMAP** service department
- In order to avoid scales on the solution tank filter, do not fill the detergent solution many hours before the machines' use
- Before using the machine, check that all doors and coverings are in their position as indicated in this use and maintenance catalogue
- Be sure the recovery tank is empty before removing it
- Provide for the scrapping of the material of normal wear following strictly the respective rules
- When, after years of precious work, your **FIMAP** machine has to be abandoned, provide for the scrapping in appropriate centres, because of the presence of toxic-harmful materials, especially oils, batteries and electronic components, and considering that the machine itself has been constructed using materials integrally recyclable.



MACHINE PREPARATION

3. INSTALLATION OF THE BATTERIES INTO THE MACHINE

The batteries must be housed in the battery compartment below the recovery tank. They must be handled using special hoisting equipment with suitable grasping systems and designed to support the weight of the batteries. The batteries must also conform to the requirements given in CEI 21-5 standards.



ATTENTION! Comply scrupulously with the instructions given by the manufacturer or his retailer for daily battery charging and maintenance. All installation and maintenance procedures must be done by expert personnel. Danger of inhalation of gases and leakage of corrosive fluids. Danger of fire: do not approach with open flames.

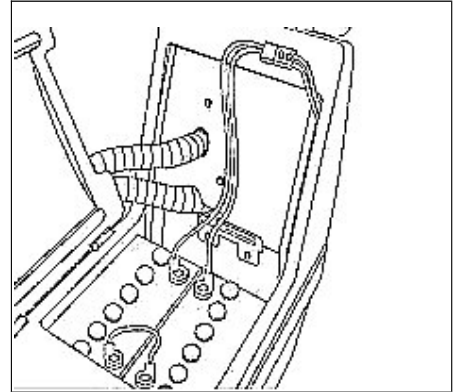

4. CONNECTING THE DRIVE MOTOR CABLE



ATTENTION! This job must be done by a Fimap Service Center technician.

5. CONNECTING THE BATTERY CHARGER

The battery connector (1) must fit into the corresponding connector on the battery charger. The battery charger connector is delivered inside the bag that contains this instruction booklet. It must be fitted to the battery charger cables according to instructions.



ATTENTION! This operation must be completed from qualified staff. A wrong or imperfect connection of cables to the connector can cause to serious damages to persons or things.

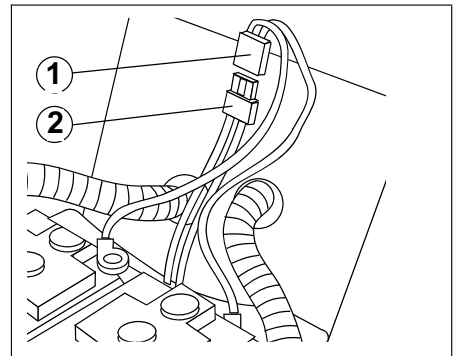

6. RECHARGE OF THE BATTERIES

Batteries, to avoid permanent harm to them, should never be totally discharged. They should be recharged within a few minutes after the battery discharged signal starts to flash.



ATTENTION! Never leave the batteries completely discharged, even if the machine is not being used. When recharging the batteries, keep the recovery tank lifted supporting it with the prop as indicated in figure. Make sure that the battery charger is suitable for the used batteries capacity and type.

ATTENTION! Danger of gas exhalations and emission of corrosive liquids
ATTENTION! Fire danger Do not approach with free flames

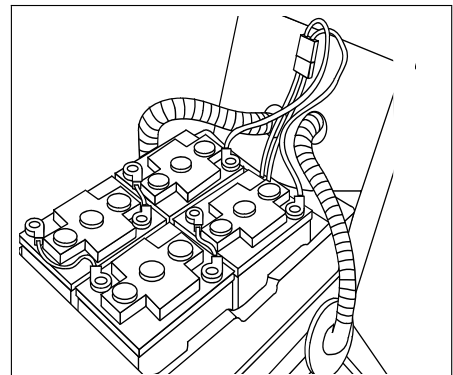



MACHINE PREPARATION

7. CONNECTION OF THE BATTERY CONNECTOR

The battery connector (2) has to be connected to the connector of the machine (1)

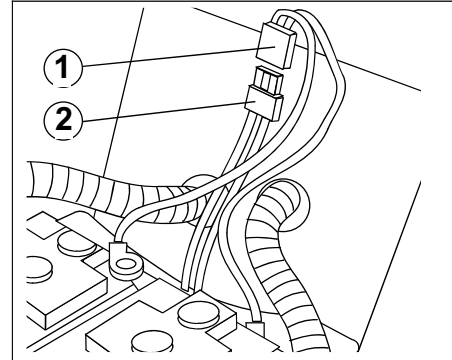

8. BATTERIES' INDICATOR (machines with traction)

The batteries' indicator is digital with 4 fixed positions and a blinking one. The numbers, which appear on the display, show the approximate charge level.

4 = maximum charge, 3 = charge 3/4, 2 = charge 2/4, 1 = charge 1/4,
0 = (blinking) discharged batteries)



ATTENTION! Some seconds after that "0" blinks, the brush motor automatically switches off. Anyway, the machine can finish to dry before recharging the batteries.

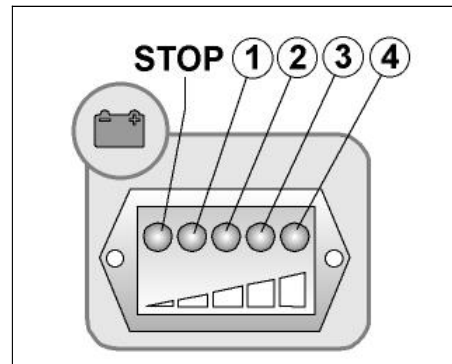

9. SQUEEGEE ASSEMBLY

The squeegee is supplied separately, dismantled from the machine, for packing reasons. It must be installed as illustrated, threading the retaining pin into the squeegee column. Put the aspiration tube into its sleeve.

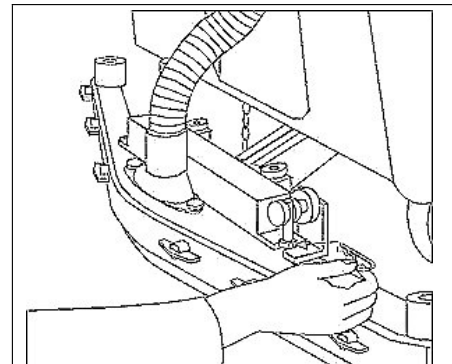

10. ADJUSTMENT SQUEEGEE HEIGHT

The squeegee has to be regulated depending on the wearing of the rubbers. To adjust this, rotate the knob (2) counterclockwise to lift the squeegee and clockwise to lower it.

Note: The right and left wheels must be adjusted at the same amount so that the squeegee works in parallel to the floor.

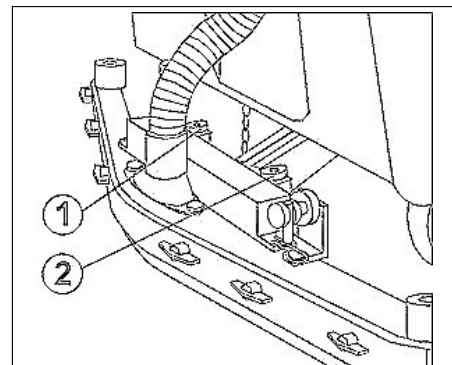



MACHINE PREPARATION

11. ADJUSTMENT SQUEEGEE INCLINATION

During working operation, the rear rubber has to work slightly tilted backwards and this equally in its whole length for about 5mm. Should it be necessary to increase the rubber bending in the central part, then tilt the squeegee body backwards and turn the adjuster (1) counterclockwise. If the rubber bending is to be noticeable at the sides of the squeegee, turn the adjuster clockwise. At the end of the adjustment, block the adjuster nut.

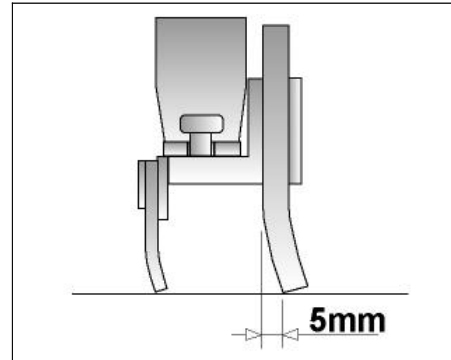

12. MANUAL BRUSHES ASSEMBLY

1. Use lever (1) to lift the base (lever downwards).
2. Turn key (2) to OFF and remove it from the control panel.



ATTENTION! installing the brushes with power on may cause injury to the hands

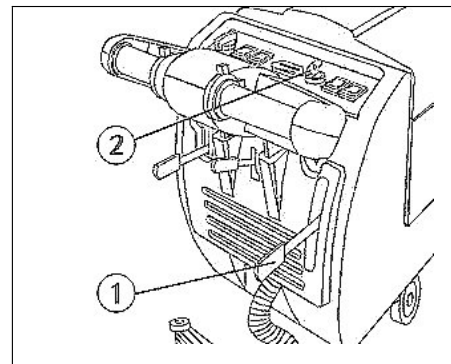

1. With the base raised thread the brushes into the seat on the plate below the base, turning them until the three buttons enter the holes on the plate. Turn them abruptly to push the button towards the retaining spring so that the brush locks in place.

The photo shows the direction of rotation for installing the right brush. Rotate the opposite direction to install the left brush.

For the single brush models the procedure is the same and the rotation direction for the brush coupling is the opposite of what indicated on the picture.

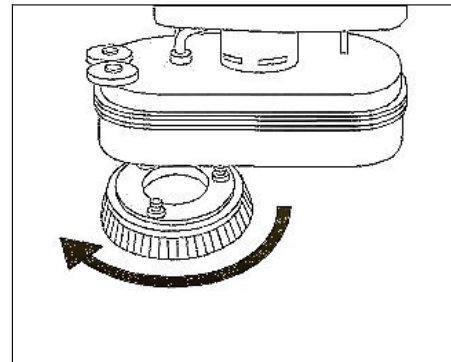

- (Only for double brush machines)

We recommend inverting right and left brushes every day and vice versa. If brushes are not new and have distorted bristles then it is best to install them always in the same position (the right brush on the right side and the left brush on the left side) to prevent bristles with a different slope from overloading the brush motor and causing excess vibrations.

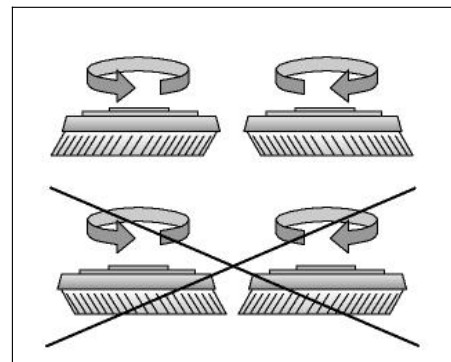



MACHINE PREPARATION

13. ASSEMBLY CYLINDRICAL BRUSHES

1. Brake the machine acting upon the lever (1)
2. Lift the brush base acting upon the lever (2)
3. Turn the key (1) into position "0" and take it of
4. Remove the lateral right splash guard (see DISASSEMBLY AND CLEANING OF THE BRUSH UNIT)



ATTENTION! Use gloves for this operation in order to protect your hands

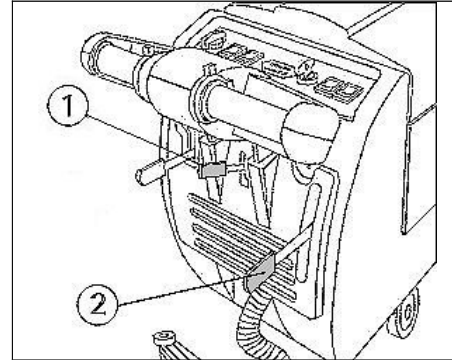

1. Insert the brush in the tunnel (Side with 5 teeth) until it is coupled with the traction hub
2. Insert the free hub (1) of the mobile support into the brush (side with 6 teeth)
3. Repeat the operation for the second brush
4. Assemble the lateral splash guards (2)

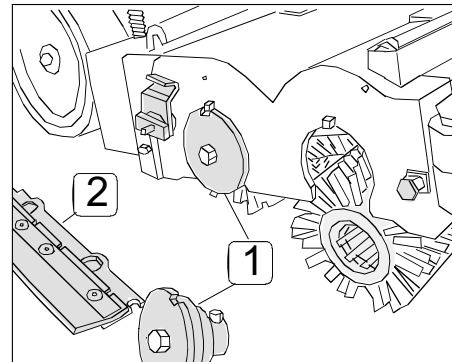

14. RECOVERY TANK

Open hood (1).

Check:

1. that plug (2) is properly anchored (it must not pull out when it is lifted, otherwise turn it clockwise);
2. that aspiration tube (3) is inserted in its seat.

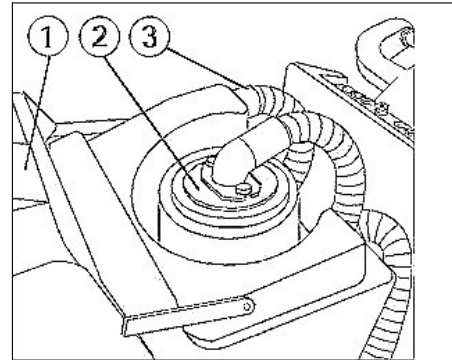

15. SOLUTION TANK

Fill the solution tank with clean water at a temperature not in excess of 50°C. Add liquid detergent in the amounts and using the procedures recommended by the detergent manufacturer. Use only a minimal percentage of detergent to prevent formation of an excess quantity of foam since too much foam may damage the aspiration motor.



ATTENTION! Always use low-foam detergent. Introduce a small amount of anti-foam detergent in the recovery tank before starting to work to be sure to prevent foam from being generated.
Never use pure acids.

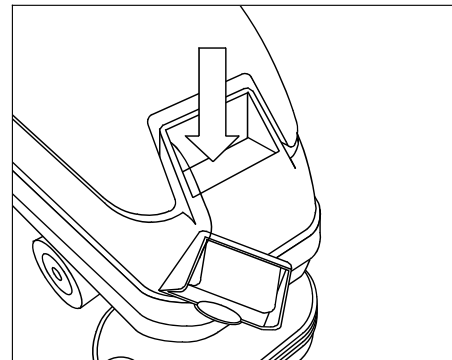



PERFORMANCE

1. SETTING FOR WORK

1. Set the machine up for operation.
2. Check that the parking brake is released (1).
3. Connect the connector to the batteries (2).
4. Turn the main switch key (3) a quarter turn clockwise. The battery led display immediately comes on.

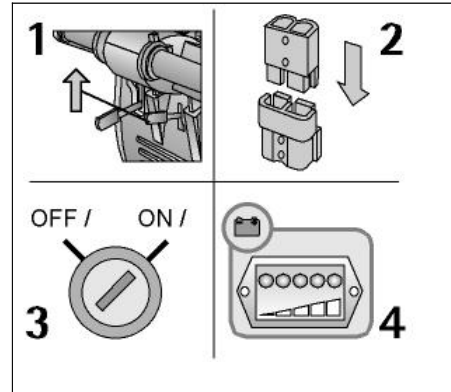

5. Press brush switch (1).
6. Press aspiration switch (2).
7. Use knob (3) to adjust water flow.

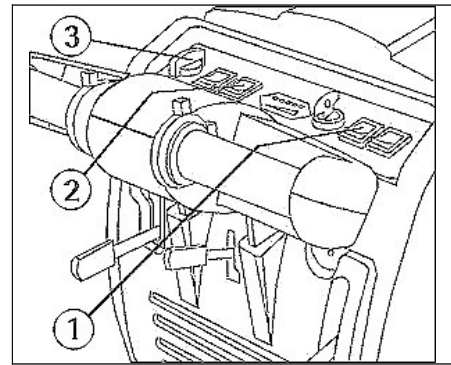

8. Push the lever (1) to lower the base.
9. Pushing the lever, lower the squeegee assembly (2).

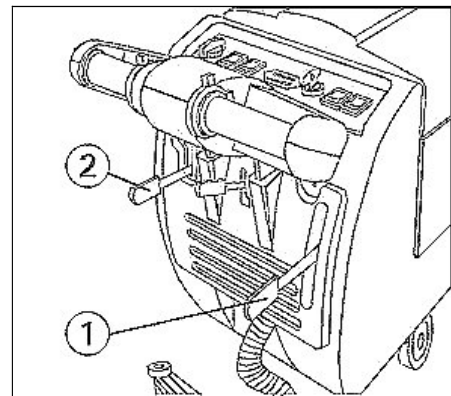

9. (Only machines with traction motor)

The machine will start to move when deadman lever (1) is pushed forward. Check, during the first few meters of wash, that brush pressure is adequate (see "BRUSH PRESSURE" below), that the amount of water is sufficient and that the squeegee dries the floor perfectly.

The machine will now start to work at full efficiency until the solution water is finished. Immediately apply emergency brake (2) on the left side of the machine whenever problems arise during operation. This control stops forward movement by the machine. To start to work again, after solving the problem, just raise level (2) and push deadman lever (1) forward.

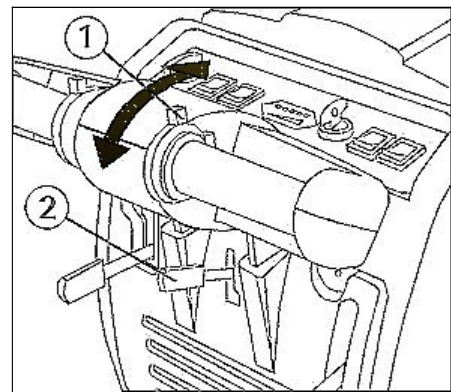



PERFORMANCE

2. OVERFLOW DEVICE

The machine is equipped with a float, which intervenes when the recovery tank is full causing the closure of the suction hose. In this case, it is necessary to proceed with the emptying of the recovery tank taking off the plug of the exhaust pipe.



ATTENTION! This operation has to be carried out using gloves to protect from contact with dangerous solutions.

3. BRUSH PRESSURE

Use lever (1) to adjust brush pressure. There are three preset positions. The greatest pressure is when the lever is in its highest position. Pressure should be selected depending on the type of floor and the amount of dirt. Too much pressure causes increased brush wear and greater energy consumption.

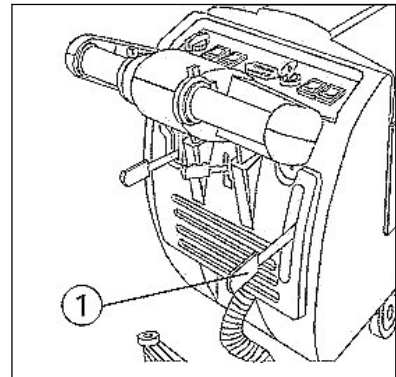

4. MOVEMENT (machines with traction)

These machines are equipped with electronically commanded traction, with two speeds forwards and one backwards.

To move the machine, it is necessary to act upon the key (1), wait for three seconds and then rotate forward (forward movement) or backward (rear movement) the lever (2) on the handle bar. Pushing forward the lever a few millimetres, the first speed is available, pushing the lever forward completely, the second speed is obtained.

In reverse motion, the speed movement is reduced.



WARNING! When carrying out even short backward movements, make sure that the squeegee is lifted.

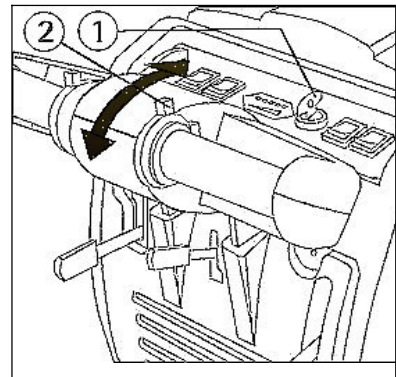

5. BRAKES (machines with traction)

The machine has two braking systems: a working electronic brake integrated in the drive system (1) and an emergency brake which works by pushing downwards the lever (2), which works also as parking brake when it is fixed in the proper hooking down on the right.

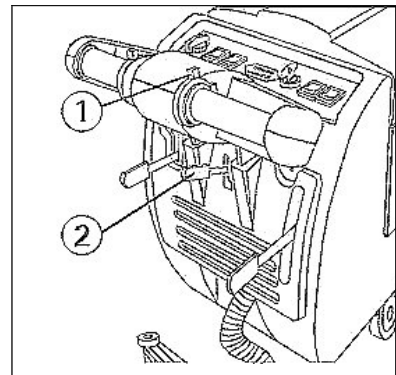



ON COMPLETION OF THE WORK

At the end of the work day, before performing any type of maintenance:

1. Close cock (3).
2. Raise base (1).
3. Raise squeegee (2)

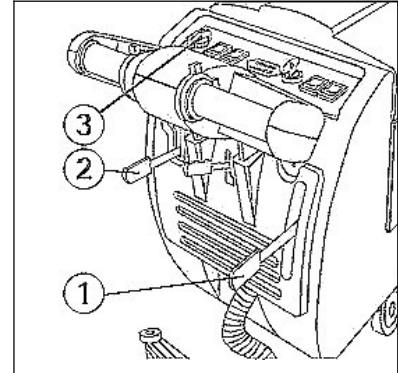

4. Turn off brush switch 1).
5. Turn off aspiration motor switch (2).
6. Move the machine to the water disposal point.
7. Turn key (3) to turn the machine off.

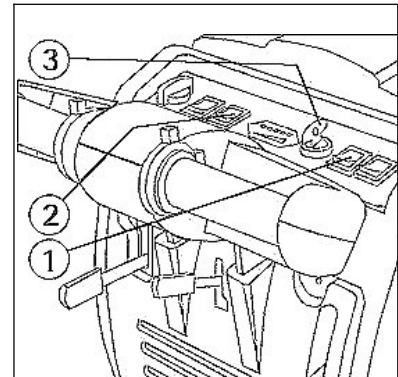

8. Lift hood (1). This frees recovery tank drain tube (2).
9. Remove the drain tube from its seat, unscrew the drain plug and empty the recovery tank (Lift the left side of the tank a few centimeters to accelerate final emptying phases). These operations must be performed wearing rubber gloves to protect against contact with dangerous solutions.
10. The squeegee should be raised when the machine is not in use to prevent permanent distortion of the rubber strips.
11. Remove the brushes and clean them with a jet of water (see "BRUSH REMOVAL" below).

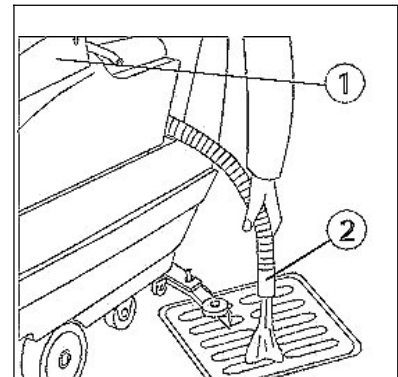

ATTENTION! This operation has to be carried out using gloves to protect from contact with dangerous solutions.

12. Push the knob (1) toward the rearpart of the machine and unhook the splash guard.
13. Extract the hopper and clean it thoroughly.



ATTENTION! This operation has to be carried out using gloves to protect from contact with dangerous solutions.

14. Lift the sweeping group on completion of the work to avoid brushes deformation.

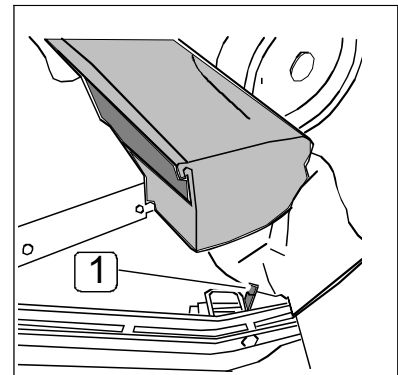



DAILY MAINTENANCE

1. CLEANING RECOVERY TANK

1. Open the hood (1).
2. Remove the drain tube (2) from its seat.
3. Empty the tank through the drain tube by turning the knob a few turns and then pulling out the plug.



ATTENTION! This operation has to be carried out using gloves to protect from contact with dangerous solutions.

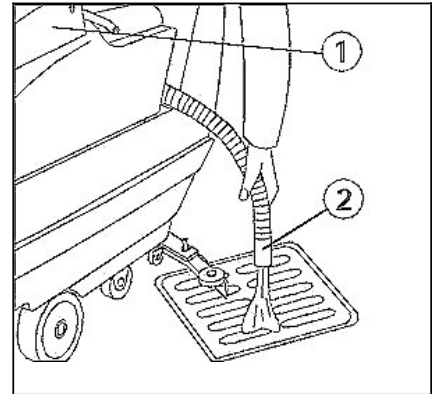

1. Remove plug (1) from the recovery tank..
2. Pull out the filter with its foam-protection unit.
3. Rinse the inside of the tank thoroughly with a jet of water. Slightly lift the tank, using its handle, to improve dirt removal.
4. Put the tank back in the machine and put the plug back on the drain tube.



ATTENTION! This operation has to be carried out using gloves to protect from contact with dangerous solutions.

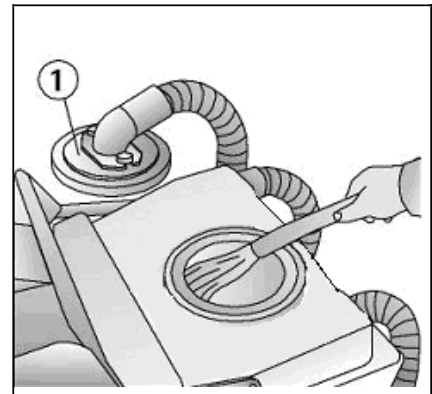

2. CLEANING THE SUCTION FILTER

1. Remove the suction unit from the tank.
2. Remove the black guard by making a circular movement (1).
3. Detach filter (2) and clean it carefully with a jet of water.
4. Reinstall everything by performing these procedures in reverse order

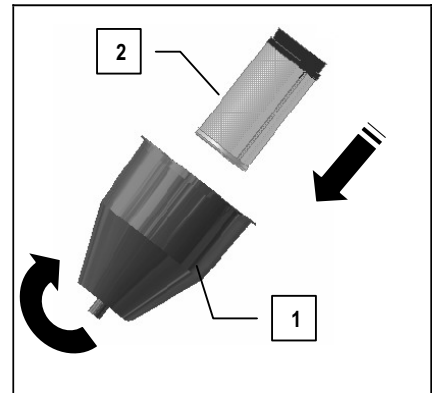

3. CLEANING THE SQUEEGEE

The squeegee must be in perfect working condition to achieve a good drying process: it must be clean and its rubbers must be in good condition. Proceed as follows to clean the squeegee:

1. Remove it from the machine by pulling pin (1) out from column (2). Clean the interior with a jet of water.
2. Loosen knobs (3), remove block (4) and check that there is no dirt inside.
3. Check the condition of the rubbers and replace them as necessary.
4. Replace everything on the machine.

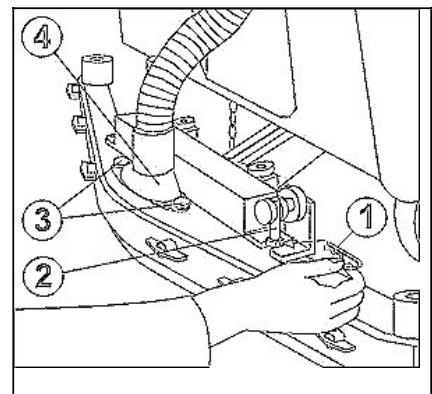



DAILY MAINTENANCE

4. REPLACEMENT OF THE SQUEEGEE RUBBERS

Check the squeegee rubber wear and if necessary, change them. To replace them:

1. Take off the suction hose from its coupling.
2. Take off the the pin from the stud bolt.
3. Remove the squeegee from its support.
4. Remove the wing nuts which block the rubber blades and take them off.
5. Replace the rubbers.
6. To reassemble the squeegee repeat the abovementioned operations.

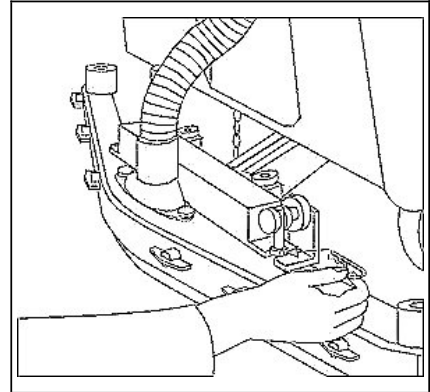

5. MANUAL BRUSHES REMOVAL

7. Push lever (1) down to raise the base.
8. Turn key (2) to OFF and remove it from the control panel (removing the brushes with power on may cause injury to the hands).



ATTENTION! During this operation make sure that, there are not any objects or persons close to the brush.

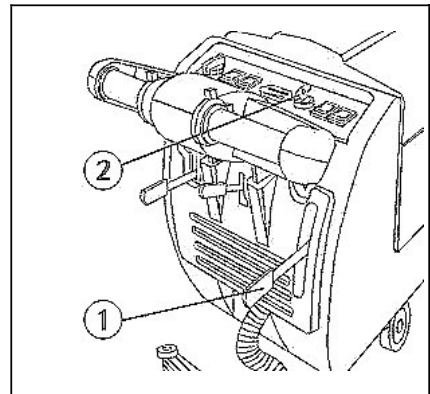

1. Rotate the brush, with the base raised, until it exits from the brush-bearing plate as illustrated. The picture shows the direction of rotation for releasing the right brush. Rotate in the opposite direction for the left brush
2. For single brush versions the procedure is the same and the rotation direction for brush release is the opposite of what indicated on the picture.



ATTENTION! During this operation make sure that, there are not any objects or persons close to the brush.

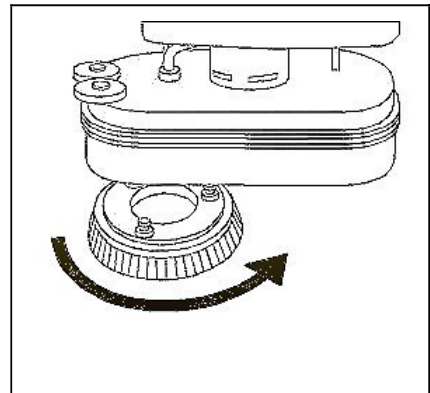

6. DISASSEMBLY OF BRUSHES (Only scrubbing-sweeping models)

To take off the brooms:

1. Lift the brush base acting upon the lever (2)
2. Brake the machine acting upon the lever (1)

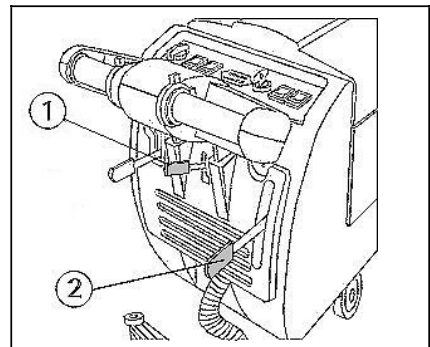



DAILY MAINTENANCE

3. Clean the hopper as under item 13, paragraph "ON COMPLETION OF THE WORK"
4. Make sure that, at the brushes ends nothing is coiled up like wires, plastic or anything else which does not allow the free brushes rotation. Otherwise:
 1. Unscrew the wing nut (1)
 2. Take off the plate (2)
 3. Remove the splash guard (3)

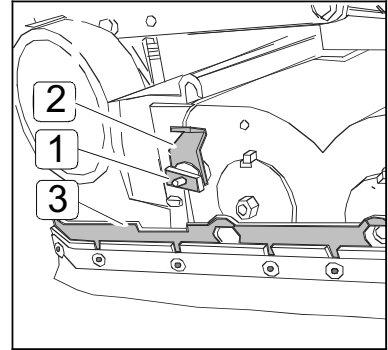

4. Take off the plugs (1)
5. Extract and clean the brushes .



ATTENTION! Make sure that, during this operation the general key is turned into position "0"

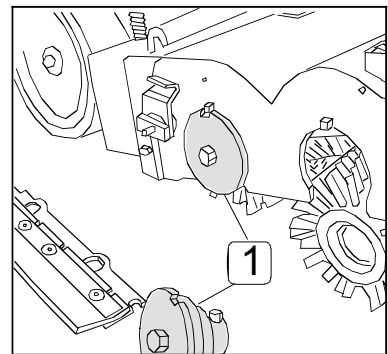

7. BRUSH REMOVAL WITH AUTOMATIC COUPLING-RELEASE (Optional)

Turn the brushes switch off and press the brushes/brush release button until the brushes release.

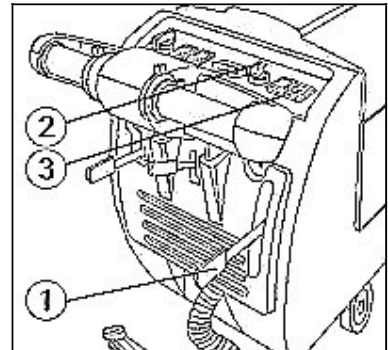



WEEKLY MAINTENANCE

1. CLEANING OF THE SQUEEGEE HOSE

Weekly or whenever suction seems to be unsatisfactory check that the squeegee hose is not obstructed. Eventually, clean it proceeding as follows:

5. Take off the hose from its coupling on the squeegee
6. Take off the other end from the recovery tank.
7. Wash the inner part of the hose with a water jet introduced from the side where it is being connected to the tank.
8. To reassemble the hose repeat the above-mentioned operations inversely.



ATTENTION! Do not wash the hose, which goes from the suction motor to the suction plug.

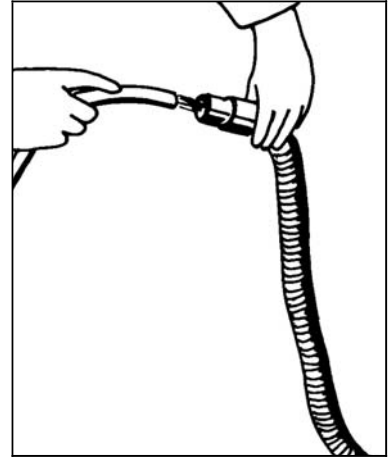

2. CLEANING SOLUTION TANK

1. Unscrew the plug on the solution tank
2. Rinse with a water jet
3. Unscrew the exhaust plug (1) and empty the tank



ATTENTION! This operation has to be carried out using gloves to protect from contact with dangerous solutions.

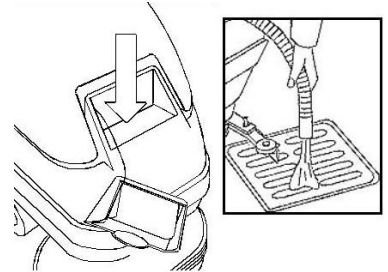



TROUBLE SHOOTING GUIDE

1. INSUFFICIENT WATER ON TO THE BRUSH

4. Check that the cock is open (signal lamp on).
5. Check that there is water in the solution tank.

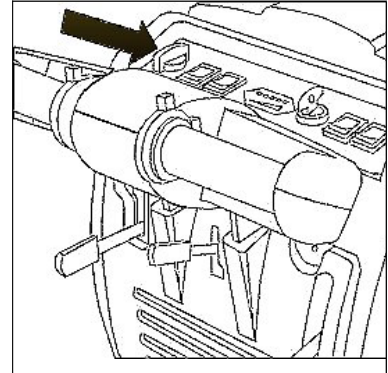

2. MACHINE DOES NOT CLEAN WELL

6. Check the condition of the brushes and replace if necessary (brushes must be replaced when bristles are 15 mm. high).
7. Check that brush pressure is sufficient. Increase as necessary using lever (1).
8. Use another type of brush rather than the standard brush. We recommend, to clean floors with exceptionally difficult dirt, the use of special brushes that are supplied on request and according to your specific needs (see "BRUSH SELECTION AND USE" below).

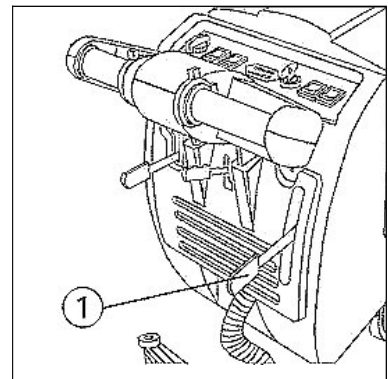

3. SQUEEGEE DOES NOT DRY PERFECTLY

1. Check that the squeegee is clean.
2. Check all adjustments (see "PREPARING THE MACHINE").
3. Clean the entire aspiration unit (see "DAILY MAINTENANCE").
4. Replace worn rubbers.

4. SUCTION MOTOR DOES NOT WORK

1. Check if the suction motor switch (1) is ON. Check if the main key switch is ON.
2. Check if the recovery tank is full.

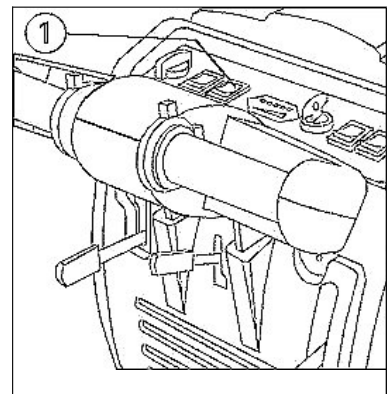

5. TOO MUCH FOAM FORMATION

1. Check that low-foam detergent is used. Add, if necessary, a small quantity of anti-foam liquid to the recovery tank.

Remember that more foam is generated when the floor to be cleaned is not very dirty. In this case use a more diluted detergent solution



SMALTIMENTO



ATTENZIONE: Il prodotto, giunto a fine vita, deve essere conferito ai punti di raccolta differenziata messi a disposizione dell'utente finale.





CHOICE AND USE OF BRUSHES

POLYPROPYLENE BRUSH (PPL)

It is used on all types of floors which are hot water resistant (not more than 60°C). The Polypropylene brush is nonhygroscopic and therefore conserves its characteristics even if working in the wet conditions.

NYLON BRUSH

It is used on all types of floors with excellent wear and hot water resistance (more than 60°C). The nylon is hygroscopic and so, over time, loses its characteristics working on the wet.

ABRASIVE BRUSH

The brush bristles are charged with very aggressive abrasives. It is used to clean very dirty floors. To avoid floor damages, work strictly only with the necessary pressure.

STEEL BRUSH

The bristles are made of steel wires; it is used to descale floors which are anyhow resistant to the abrasion, very uneven or with wide joints.

THICKNESS OF THE BRISTLES

The thicker the bristles are, the more rigid they will be. These ones are therefore used on smooth floors or with small joints. On uneven floors with deep joints it is recommended that, softer bristles, which enter more easily in depth, are used.

Please bear in mind that, when the bristles are worn out and get too short, they will get rigid and cannot penetrate anymore. As well as for thick bristles, the brush will begin to jump.

PAD HOLDER

The pad holder is recommended to clean glossy areas.

There are two types of pad holders:

1. The traditional pad holder is equipped with anchor points, which allow the abrasive pad to be held and dragged during the work process.
2. The pad holder is of the CENTER LOCK type, apart from the anchor points, is equipped with a central blocking release system made in plastic. This allows a perfect match with the abrasive pad and to hold it without the risk of falling down. This type of pad holder is recommended especially for machines with more brushes, where the centering of the pads is difficult.

LIST FOR THE CHOICE OF THE BRUSHES

Machine	Q.ty	Code	Bristles type	Thick Ø	Brush	Notes
MAXIMA 450	1	404645	PPL	0.4	455	Pad blocking
		404644	PPL	0.6	455	
		404643	PPL	0.8	455	
		404646	ABRASIVE	1	455	
		405523	Pad holder Center Lock	-	455	
MAXIMA 500	1	414266	PPL	0.4	500	Pad blocking
		414267	PPL	0.6	500	
		414268	PPL	0.8	500	
		414269	ABRASIVE	1	500	
		405527	Pad holder Center Lock	-	500	
MAXIMA 452	2	405578	PPL	0.3	210	
		405579	PPL	0.6	210	
		405580	PPL	0.8	210	
		414274	ABRASIVE	1	210	
		405510	Pad holder	-	210	
MAXIMA 502	2	405601	PPL	0.3	255	
		405604	PPL	0.6	255	
		405602	PPL	0.8	255	
		405603	ABRASIVE	1	255	
		405513	Pad holder	-	255	
MAXIMA 650	2	422189	PPL	0.3	340	Pad blocking
		422971	PPL	0.6	340	
		422972	PPL	0.9	340	
		422981	ABRASIVE	1	340	
		422973	Pad holder	-	330	
MAXIMA 50BS-BTS	1	405639	PPL WHITE	0.5	110x500	Front brush more rigid
	1	405640	PPL LIGHT BLUE	0.3	110x500	Rear brush
	1	405641	ABRASIVE GREY	0.6	110x500	Front brush



CE STATEMENT OF COMPLIANCE model Maxima 450/500/452/502/650/50

The undersigned company:

FIMAP S.p.A.

Via Invalidi del Lavoro n.1
37050 Santa Maria di Zevio (VR)

states under its own exclusive responsibility that the product

FLOOR SCRUBBING MACHINE model Maxima 450/500/452/502/650/50

complies with the provisions of Directives:

- 98/37/EEC: Machine directive.
- 89/336/EEC: Electromagnetic compatibility directive and following modifications 91/263/EEC, 92/31/EEC and 93/68/EEC.

Inoltre è conforme alle seguenti norme:

- EN 60335-1: Safety of electric home appliances and the like – Safety. Part 1: General regulations.
- EN 60335-2-72: Safety of electric home appliances and the like. Part 2: Special regulations for automatic machines for processing industrial and community-use floors.
- EN 12100-1: Machine safety – Basic concepts, general design principles – Part 1: Base terminology and methodology.
- EN 12100-2: Machine safety – Basic concepts, general design principles – Part 2: Technical principles.
- EN 61000-6-3: Electromagnetic compatibility (EMC) - Part 6-3: General standards – Emission for residential, commercial and light industrial environments.
- EN 61000-6-1: Electromagnetic compatibility (EMC) - Part 6-1: General standards – Immunity for residential, commercial and light industrial environments.
- EN 50366: Appliances for home use and the like – Electromagnetic fields – Evaluation and measurement methods.

Santa Maria di Zevio, 05/02/2007

FIMAP S.p.A.
Legal Representative

Giancarlo Ruffo

FIMAP spa
Via Invalidi del Lavoro, 1 - 37050 S.Maria di Zevio (Verona) Italy
Tel. +39 045 6060411 r.a. - Fax +39 045 6060417 - E-mail: fimap@fimap.com - www.fimap.com

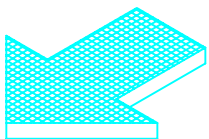
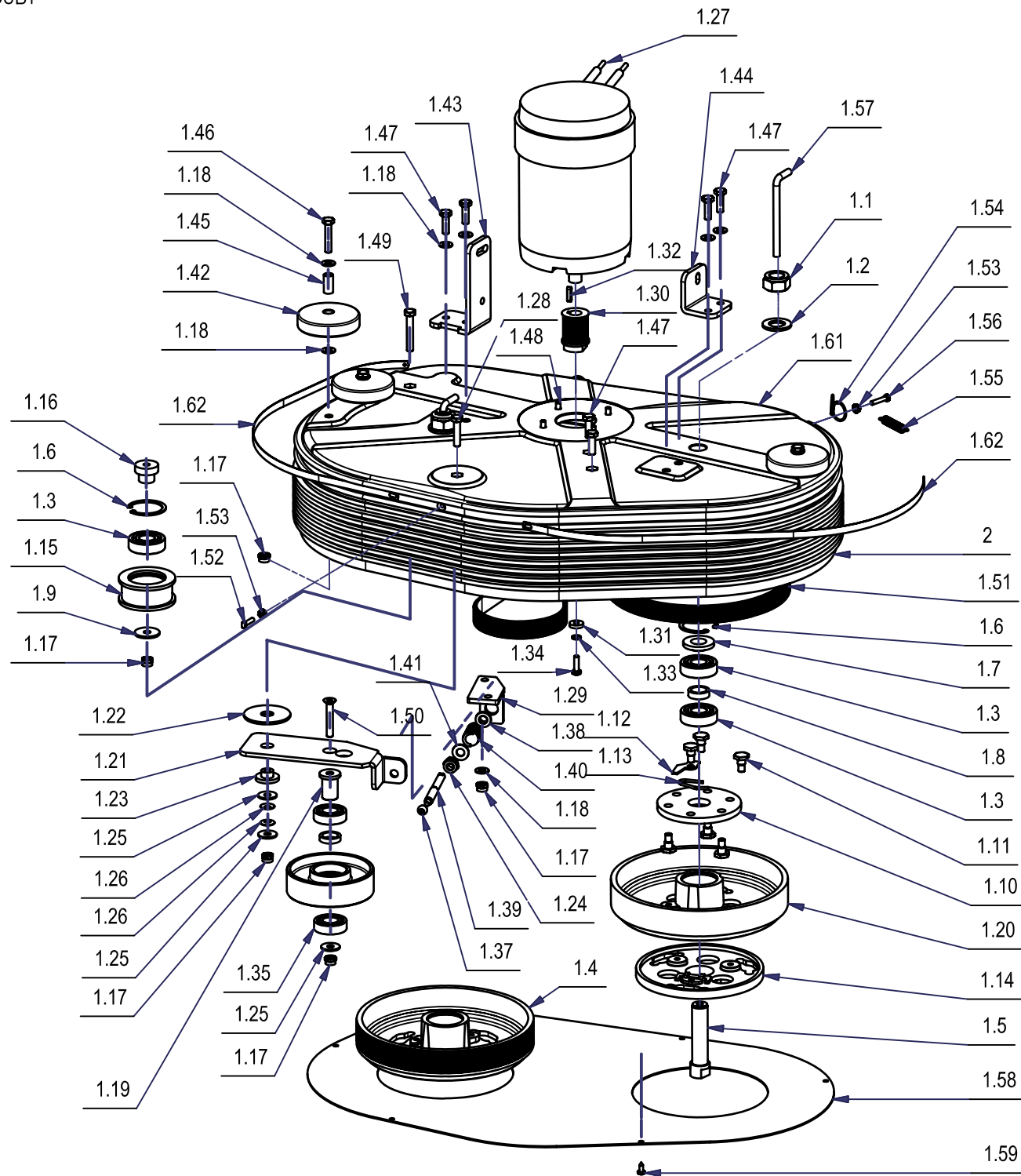

ITEM	SKU	DESCRIPTION	QTY
1	213390	BRUSH BASE	1
1.1	E88015	Nut, Lock M20	2
1.2	E20253	Flat Washer M21x60x3 Nylon	2
1.3	E81657	Bearing, 6204 2RS	5
1.4	210260	PULLEY	1
1.5	E87284	Shaft	2
1.6	E81656	Retaining Ring - Internal	3
1.7	E87281	Spacer	2
1.8	E86216	Spacer	2
1.9	E81918	Flat Washer M9x32x2.5 Zinc	1
1.10	400634	FLEXIBLE COUPLING	2
1.11	203269	STUD BOLT	12
1.12	E81957	Pad driver retainer clip	2
1.13	E81953	Wire Spring Clip 75mm Custom	2
1.14	400413	BRUSH PLATE	2
1.15	E85723	Idler Pulley	1
1.16	E87279	Bushing	1
1.17	409085	LOCK NUT	12
1.18	E81874	Flat Washer M8x17x1.6 Zinc	12
1.19	213380	PIN	1
1.20	210285	PULLEY	1
1.21	203254	TIGHTENER	1
1.22	E88110	Flat Washer M6.1x60x3 Nylon	1
1.23	E88014	Bushing	1
1.24	E83381	Nyloc Hex Nut, M10 Zinc	1
1.25	E83404	Flat Washer M9x24x2.5 Zinc	3
1.26	E20126	Cupped Spring Washer M8x18x1	2
1.27	E82738	Brush Motor 24VDC 560W	1
1.28	E83801	Hex Bolt M8x35 Zinc	1
1.29	203234	SUPPORT	1
1.30	E82424	Pulley, 35 OD x 18 ID x 48mm	1
1.31	205112	WASHER	1

ITEM	SKU	DESCRIPTION	QTY
1.32	E83700	Shaft Key 5x5x20mm	1
1.33	E82774	Lock Washer, M6 Zinc	5
1.34	E82772	Hex Bolt M6x20 Zinc	1
1.35	E83923	Bearing, 6004 2RS	2
1.36	209860	SPACER	1
1.37	E88009	Bushing	1
1.38	E88007	Bushing	1
1.39	E88008	Adjuster	1
1.40	E83698	Tension Spring 20x3.5x32mm	1
1.41	E82773	Flat Washer M10x21x2 Zinc	1
1.42	E83895	Wheel 80 OD x 23 W	3
1.43	213374	SUPPORT	1
1.44	213375	SUPPORT	1
1.45	E83524	Bushing	3
1.46	E83830	Hex Bolt M8x40 Zinc	3
1.47	E83833	Hex Bolt M8x25 Zinc	6
1.48	E83547	M6x16 Bolt, Zinc Hex Head	4
1.49	E87285	Hex Bolt M8x50 Zinc	1
1.50	415831	SCREW	1
1.51	E81808	Belt, Poly VJ10 L1992	1
1.52	E83823	Screw M5x20/ SS Custom	1
1.53	E88010	Hex Nut, M5	6
1.54	E83489	Rings	2
1.55	E83491	Spring, 9.8x1.1x58mm	2
1.56	407651	SCREW	2
1.57	E82303	Pipe	2
1.58	213941	COVER	1
1.59	E88017	Screw,	6
1.60	213620	PULLEY	1
1.61	213376	BRUSHES BASE	1
1.62	E81926	Band Clamp	2
2	E86143	Splash Guard	1



GRUPPO RUOTE E TRAZIONE B-BT / BS-BTS
 WHEELS AND TRACTION ASSEMBLY B-BT / BS-BTS
 ENSEMBLE ROUES ET TRACTION B-BT / BS-BTS
 HINTERRAEDER UND ANTRIEBSGRUPPE B-BT / BS-BTS
 GRUPO RUEDAS Y TRACCION B-BT / BS-BTS

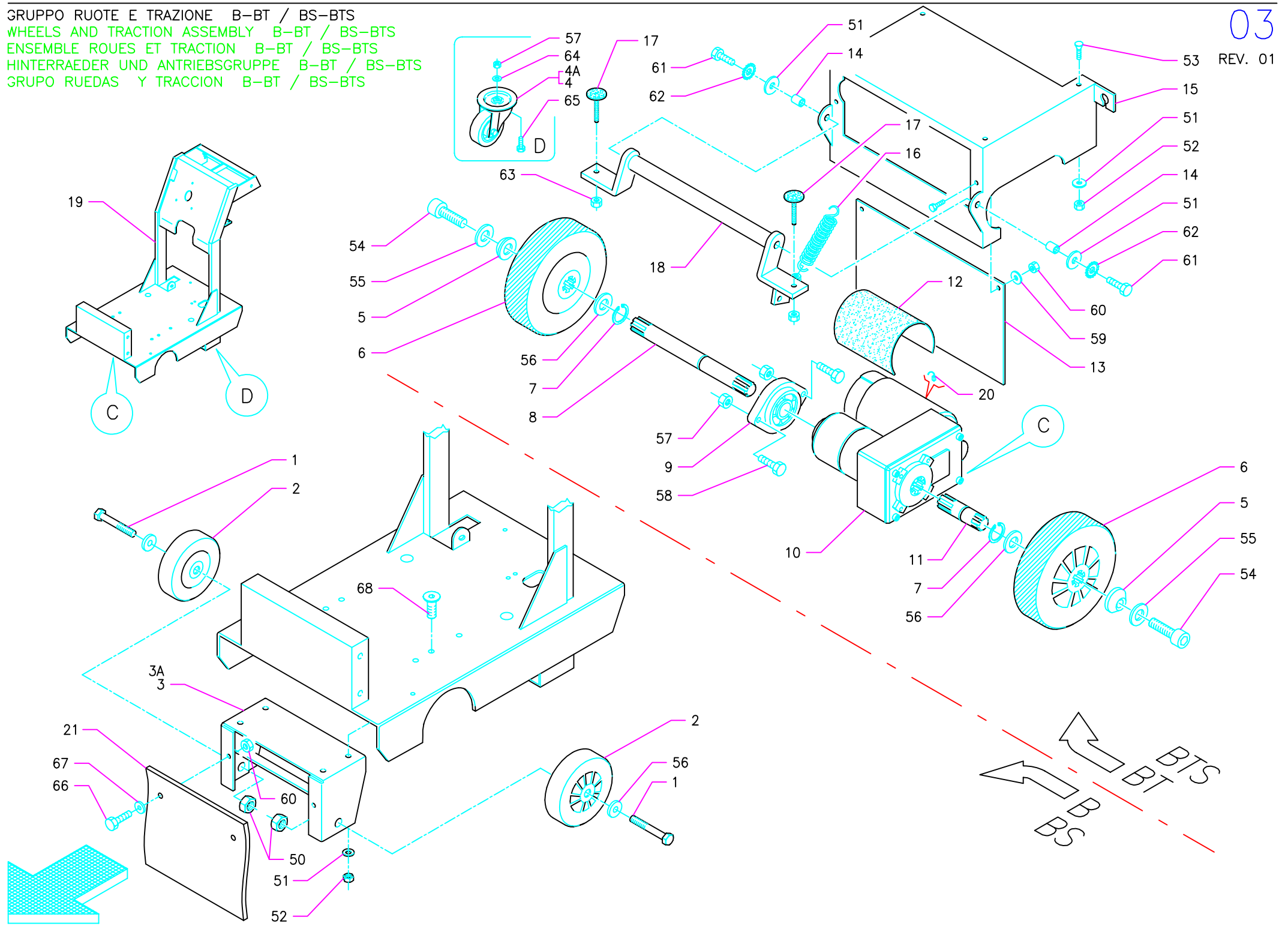

ITEM	SKU	DESCRIPTION	QTY
1	E81737	Axle	2
2	414314	WHEEL	2
3	E86175	Support	1
3A	203541	SUPPORT	1
4	E82529	Caster, Rear Abila	2
4A	414332	WHEEL	2
5	E82395	Washer	2
6	E82542	Drive Wheel 175 OD x 45	2
7	E82736	Washer	2
8	415135	AXLE-SHAFT	1
9	E88191	Flange Bearing	1
10	414603	GEARMOTOR	1
11	415136	AXLE-SHAFT	1
12	E82375	Shroud cover, motor	1
13	405975	SPLASH GUARD	1
14	200325	BUSHING	2
15	203500	SUPPORT	1
16	E81778	Spring	1
17	204371	PAD	2
18	203504	SHAFT	1
19	202566	FRAME	1

ITEM	SKU	DESCRIPTION	QTY
20	415982	CARBON BRUSH MOTOR	2
21	405975	SPLASH GUARD	1
50	-	NUT M16x1,5 AUTOBL UNI 74	-
51	-	WASHER M8 UNI 6592	-
52	-	NUT M8 AUTOBL. UNI 7474	-
53	-	SCREW M8x16 UNI 5933	-
54	-	SCREW M8x18 UNI 5931	-
55	-	WASHER M8 SCHNORR	-
56	-	WASHER M20 UNI 6592	-
57	-	NUT M10 AUTOBL. UNI 7474	-
58	-	SCREW M10x25 UNI 5739	-
59	-	WASHER M6 UNI 6592	-
60	-	NUT M6 AUTOBL. UNI 7474	-
61	-	SCREW M8x20 UNI 5739	-
62	-	WASHER M8 DIN 6798/A	-
63	-	NUT M8 AUTOBL. UNI 7474	-
64	-	WASHER M10 UNI 6592	-
65	-	SCREW M10X35 UNI 5739	-
66	-	SCREW M6X16 UNI 5739	-
67	-	ROSETTA M6 D.18 UNI 6593	-
68	-	SCREW M8X22 UNI 5933	-



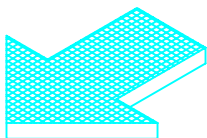
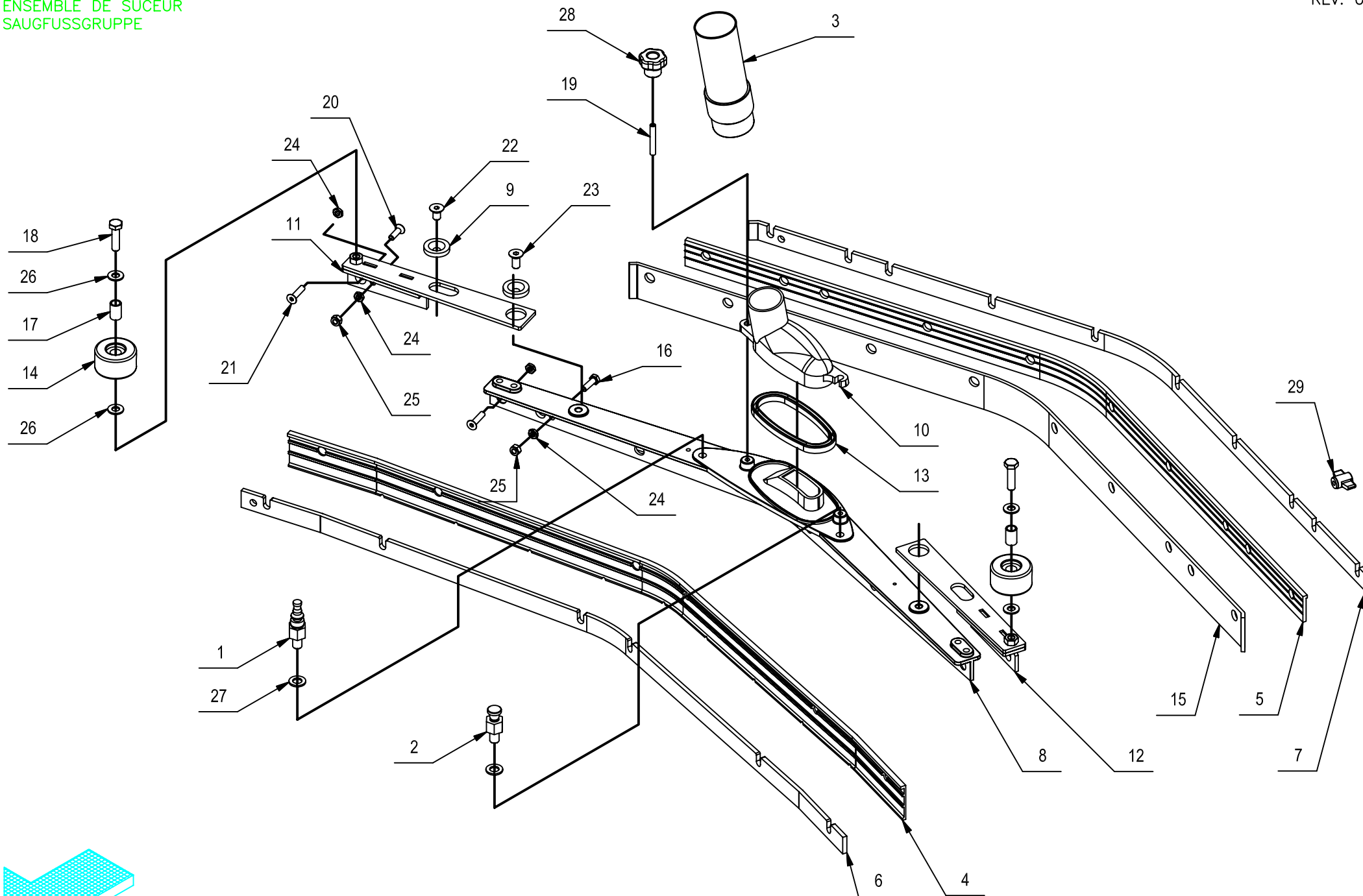

ITEM	SKU	DESCRIPTION	QTY
1	E82275	Pin, Adjustable Mounting M10 Zinc	1
2	E82280	Pin, Fixed Mounting M10 Zinc	1
3	E12666	Squeegee Vacuum Hose	1
4	E81834	Squeegee Blade, Polyurethane	1
5	E81835	Squeegee Blade, Polyurethane	1
6	210048	BLADE	1
7	210049	BLADE	1
8	210349	SQUEEGEE BODY	1
9	210511	WASHER	4
10	E82307	Squeegee Vacuum Adapter	1
11	E20572	Squeegee Shoe Extender	1
12	E20077	Squeegee Shoe Extender	1
13	E83971	Gasket	1
14	E82451	Wheel 45 OD x 25 W	2
15	E81833	Squeegee Blade, Gum Rubber	1

ITEM	SKU	DESCRIPTION	QTY
16	E83914	Hex Bolt M6x20 SS	4
17	E82253	Bushing, Brass	2
18	E83802	Hex Bolt M8x30 Zinc	2
19	E82707	Set Screw Hex Soc Flat End M6x40 SS	2
20	E83831	Flat Hd Soc Machine Screw M6x20 SS	2
21	E81848	Flat Hd Soc Machine Screw M6x25 SS	10
22	408980	SCREW	2
23	408988	SCREW	2
24	409045	NUT	16
25	E83550	NyLoc Hex Nut, M6 Zinc	6
26	E81874	Flat Washer M8x17x1.6 Zinc	4
27	E83948	Lock Washer M10x18x2.2 Zinc	2
28	E81435	Knob, M6 8-Lobe Nylon Female	2
29	E83591	Knob, M6 2-Arm Nylon Female	10



10/2003

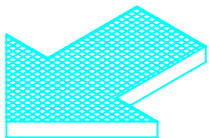
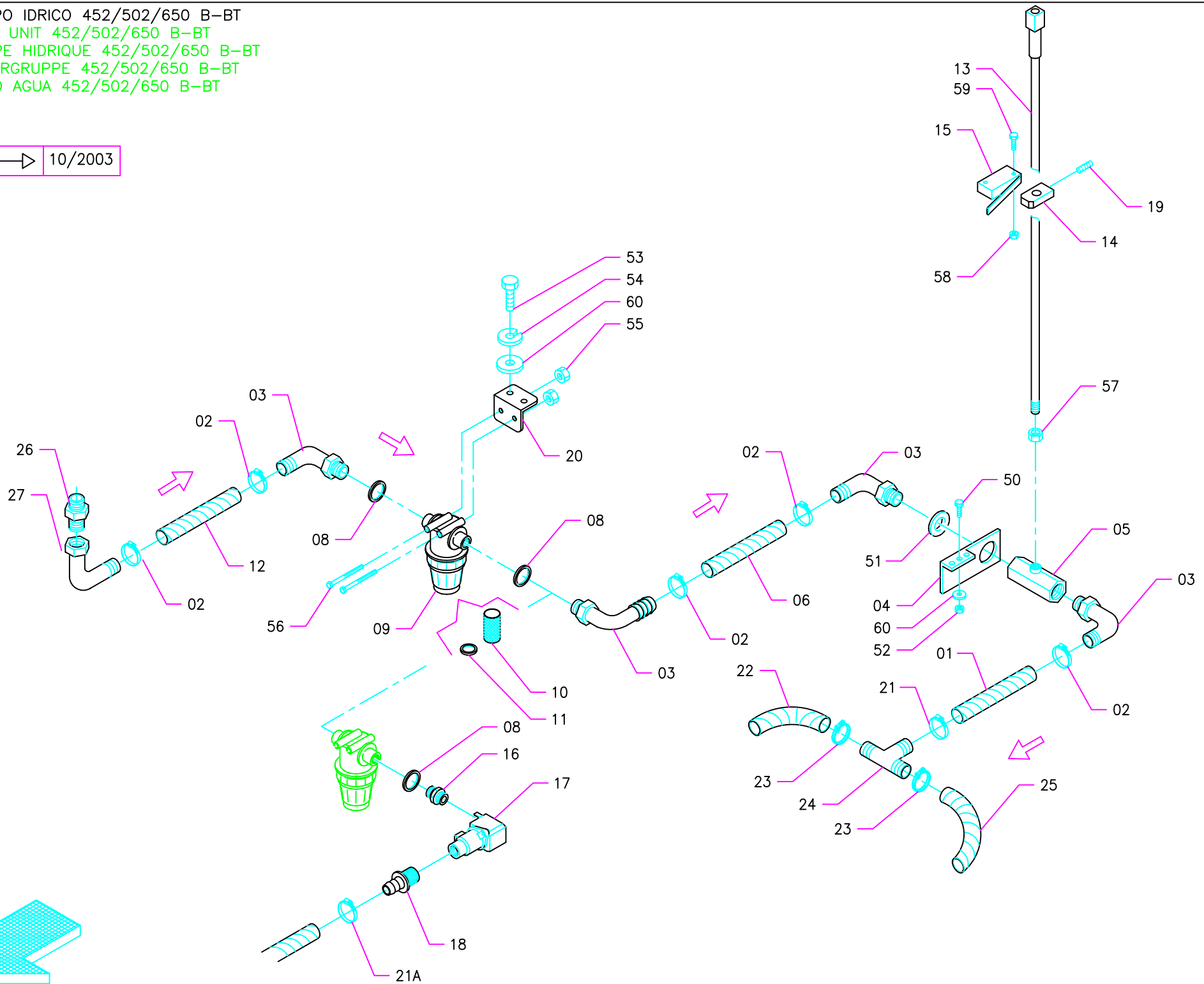

ITEM	SKU	DESCRIPTION	QTY
1	202176	TUBE	1
2	416172	CLAMP	6
3	E81454	Barbed Elbow	3
4	203391	SUPPORT	1
5	E82366	Valve	1
6	202188	TUBE	1
7	E88400	Fitting	1
8	E86178	O-Ring	2
9	E83118	Solution Filter & Housing	1
10	E83119	solution supply filter	1
11	E82341	Gasket	1
12	202172	TUBE	1
13	E87297	Valve Shaft Foreman AS2	1
14	203486	CLAMP	1
15	E83164	Micro Switch	1
16	E88085	Fitting 1/2 x 3/8 Foreman	1
17	E81035	Solenoid Valve	1
18	E82269	Barbed Fitting, 3/8 in.	1
19	415808	DOWEL	1
20	203520	SUPPORT	1

ITEM	SKU	DESCRIPTION	QTY
21	E85762	Hose Clamp	1
21A	E85762	Hose Clamp	1
22	202210	TUBE	1
23	E81565	Clamp, 4.8x200 Black	2
24	E82393	Fitting, Tee	1
25	202209	TUBE	1
26	E86251	Nipple	1
27	E85760	Gromment	1
50	-	SCREW M6X16 UNI 5933	-
51	-	WASHER M20 UNI 6592	-
52	-	NUT M6 UNI 5588	-
53	-	SCREW M6X20 UNI 5739	-
54	-	LOCK WASHER M6	-
55	-	LOCK NUT M8	-
56	-	SCREW M8X70 UNI 5737	-
57	-	NUT M5 UNI 5588	-
58	-	LOCK NUT M3	-
59	-	SCREW M3X20 UNI 5739	-
60	-	WASHER M6 UNI 6592	-



GRUPPO COMANDO SPAZZOLE B-BT / BS-BTS
 BRUSHES CONTROL ASSEMBLY B-BT / BS-BTS
 GROUPE COMMANDE DES BROSSES B-BT / BS-BTS
 GRUPPE BÜRSTENBETAETIGUNG B-BT / BS-BTS
 GRUPO MANDO CEPILLOS B-BT / BS-BTS

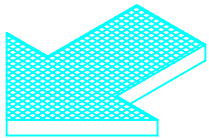
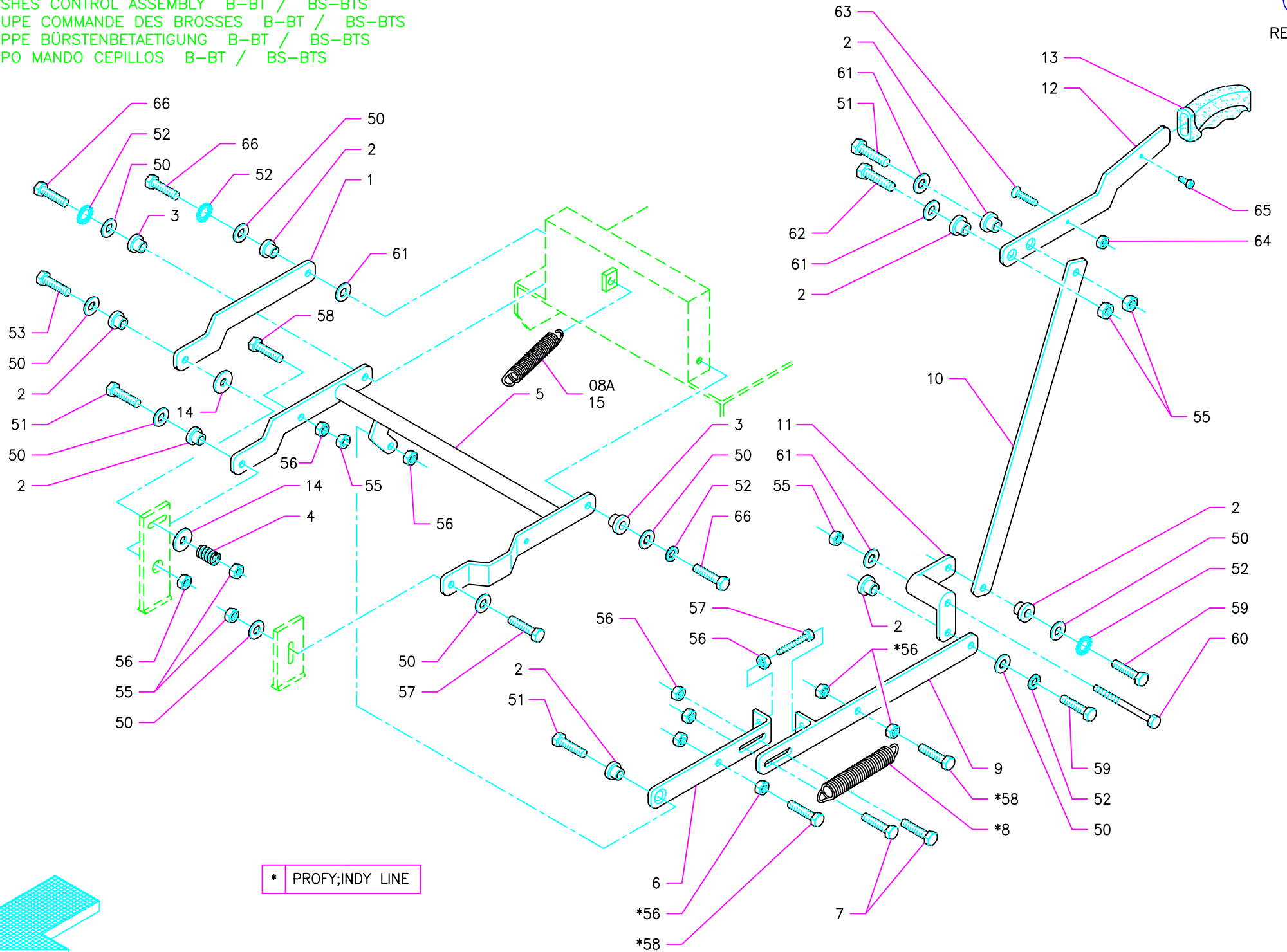

ITEM	SKU	DESCRIPTION	QTY
1	203491	ARM	1
2	E83932	Bushing	9
3	E85767	Bushing	2
4	E82309	Spring, 11.8x1.2x15mm	1
5	412449	ARM	1
6	203496	KNIFE	1
7	203495	STUD BOLT	2
8	E82837	Spring	1
8a	E82837	Spring	1
9	203494	KNIFE	1
10	203493	TIE ROD	1
11	412450	RETURN	1
12	203492	HANDLE	1
13	E81318	Knob	1
14	E83832	Flat Washer M8.5x30x3 Nylon	2
15	E81714	Spring	1
50	-	WASHER M8 D.24 UNI 6593	-
51	-	SCREW M8X25 UNI 5739	-
52	-	WASHER M8 DIN 6798/A	-
53	-	SCREW M8X40 UNI 5739	-
55	--	NUT M8 UNI 7474	-
56	-	NUT M8 UNI 5588	-
57	-	SCREW M8X30 UNI 5739	-
58	-	SCREW M8X45 UNI 5739	-
59	-	SCREW M8X20 UNI 5739	-
60	-	SCREW M8X90 UNI 5737	-
61	-	WASHER M8 UNI 6592	-
62	-	SCREW M8X25 UNI 5933	-
63	-	SCREW M6X20 UNI 5933	-
64	-	NUT M6 UNI 5588	-
65	-	SCREW Ø 4,8X13 UNI 6954	-
66	-	SCREW M8X35 UNI 5739	-



GRUPPO SERBATOI B-BT / BS-BTS
 TANK ASSEMBLY B-BT / BS-BTS
 GROUPE DE RESERVOIRS B-BT / BS-BTS
 TANKGRUPPE B-BT / BS-BTS
 GRUPO TANQUES B-BT / BS-BTS

09
 REV. 03

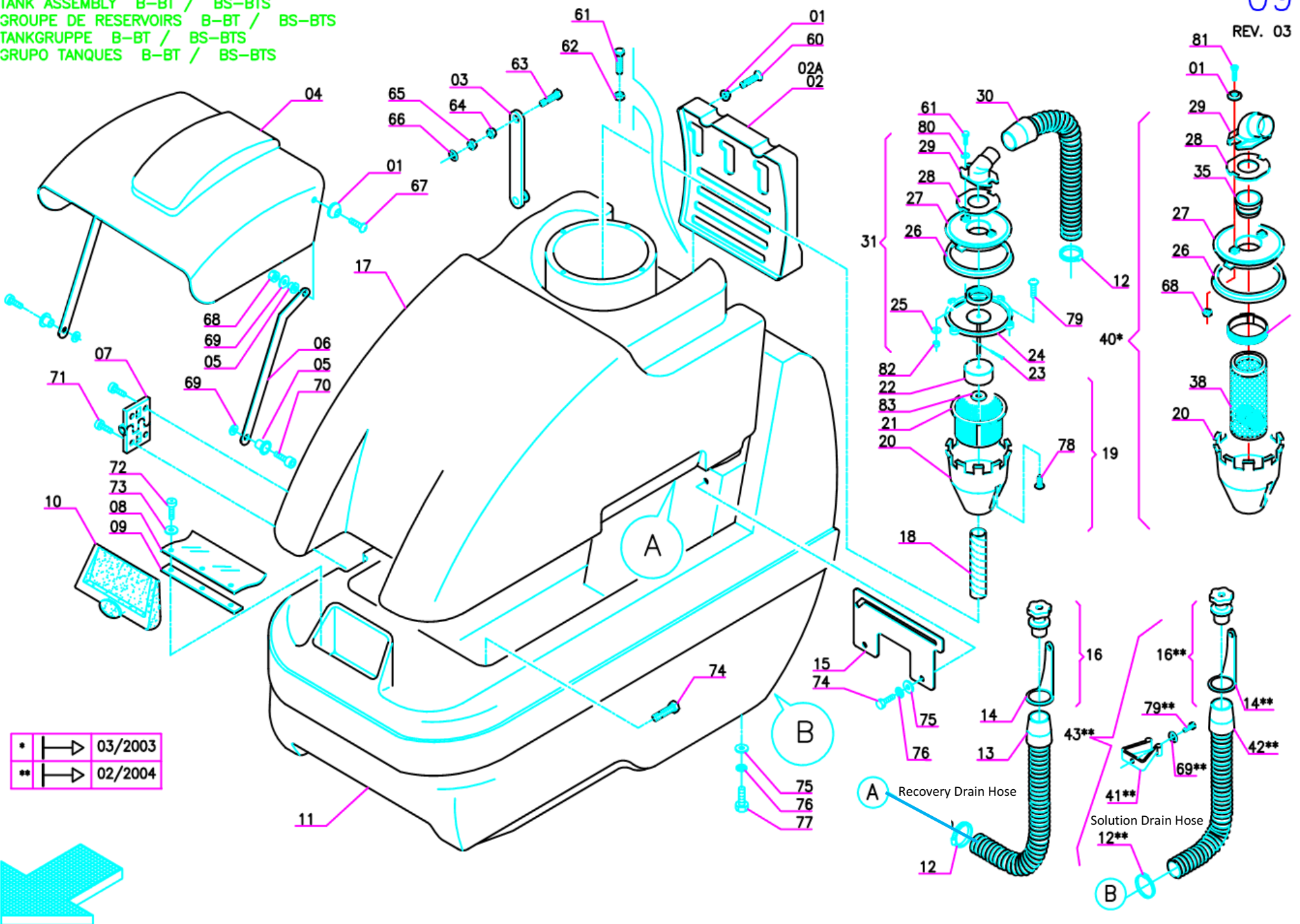

*	→	03/2003
**	→	02/2004



ITEM	SKU	DESCRIPTION	QTY
1	E83850	Flat Washer M5x20 SS	6
2	415147	COVER	1
	415148	COVER	1
3	415144	PANEL	1
4	E86195	Cover, Bonnet Gray	1
5	E88125	Bushing	4
6	E88126	Bracket	2
7	E81029	Hinge	2
8	415095	SPLASH GUARD	1
9	415096	BLADE	1
10	415094	COVER	1
11	414817	TANKS	1
12	420512	CLAMP	2
13	E86108	Drain Hose w/ Cap	1
14	420678	CLAMP	1
15	203517	BRACKET	1
16	E81887	Exhaust Plug	1
17	414818	TANKS	1
18	E87295	Tube	1
19	203163	ASM Protection/Filter	1
20	E81006	Vacuum Splash Guard	1
21	E83696	Filter CRS/DRS	1
22	E83338	Float WS17	1
23	E83605	Split pin	1
24	E83995	Ring	1
25	E88284	Washer 4 x 8 x 3 Nylon	4
26	E82381	Gasket Ring	1
27	E82450	Cover	1
28	E83994	Gasket	1
29	E82267	Coupling	1
30	E20462	Hose, Vacuum	1
31	E85756	Recovery Tank Lid Assembly	1

ITEM	SKU	DESCRIPTION	QTY
32	E81710	Hose Clamp	1
35	E88384	Fitting, Recovery Tank Hose	1
38	E82790	Air Filter/Shutoff	1
40	E88102	Recovery Filter Assembly	1
41	E81786	Hose Clip	1
42	E86290	Drain Hose	1
	202887	EXHAUST PIPE	-
43		ASSEMBLY/WATER LEVEL	
60	-	SCREW M5X16 UNI 7688	-
61	-	SCREW M4X25 UNI 5739 A2	-
62	-	NUT M4 UNI 7474	
63	-	SCREW M8X45 UNI 5739	
64	-	NUT M8 UNI 7474	
65	-	NUT M8 UNI 5588	
66	-	WASHER M8 UNI 6592	
67	-	SCREW M5X20 UNI 7687	
68	-	NUT M5 UNI 7474	
69	-	WASHER M5 D.15 UNI 6593	
70	-	SCREW M5X16 UNI 7380	
71	-	SCREW M6X14 UNI 5931	
72	-	SCREW M5X20 UNI 7687 A2	
73	-	WASHER M5 UNI 6592 A2	
74	-	SCREW M6X16 UNI 5739	
75	-	WASHER M6 D.18 UNI 6593	
76	-	WASHER DIN 6798/A	
77	-	SCREW M6X35 UNI 5933	
78	-	SCREW Ø 3.9X13 UNI 6954	
79	-	SCREW Ø 4.2X16 UNI 6954	
80	-	WASHER M5 D.20 UNI 6593	
81	-	SCREW M5X25 UNI 7688	
82	-	NUT M4 UNI5588	
83	-	WASHER M6 D.24 UNI6593	



ITEM	SKU	DESCRIPTION	QTY
1	203511	COVER	1
2	E82493	Grips, Handle	2
3	415140	PIPE	2
4	E81019	O-Ring	2
5	E82782	Washer	2
6	E85751	Trigger Lever	1
7	E81625	Shank, M5x32	2
8	203279	PIN COUPLER	2
9	415141	SHAFT	1
10	E82284	Lever	1
11	203510	HANDLE BAR BODY	1
12	E81663	Fair Lead	1
13	415142	SUPPORT PLATE	2
14	E88192	Nut	1
15	E81597	Circuit Breaker 10 amp	1
16	E88204	Spring	1
17	E81763	Cam	1
18	415810	TIE ROD	1
19	400648	SUPPORT PLATE	2
20	203508	BRACKET	1
21	E82520	Potentiometer	1
22	E20076	Pinion Gear	1
23	E82794	Microswitch	2
25	203507	BRACKET	1

ITEM	SKU	DESCRIPTION	QTY
26	414545	CABLE	1
27	E83584	Battery jumper cable	1
28	E86208	SB50 Red Electrical Connector	1
29	E86208	SB50 Red Electrical Connector	1
50	-	SCREW Ø 4,8X32 UNI 6954	-
51	-	NUT M5 UNI 5588	-
52	-	SCREW M3X20 UNI 5739 A2	-
53	-	NUT M3 UNI 7474	-
54	-	SCREW 4,8X25 UNI 6954	-
55	-	NUT M6 UNI 7474	-
56	-	SCREW M6X45 UNI 5739	-
57	-	NUT M5 UNI 7474	-
58	-	WASHER M6 D.18 UNI 6593	-
59	-	SCREW M6X20 UNI 5739	-
60	-	WASHER M6 UNI 6592	-
61	-	SCREW M8X20 UNI 5739	-
62	-	WASHER M8 DIN 6798/A	-
63	-	WASHER M8 UNI 6592	-
64	-	NUT M4 UNI 5588	
65	-	VITE M4X16 UNI 5739	
66	-	VITE M3X16 UNI 7687	
67	-	VITE 4,8X13UNI 6954	
68	-	VITE M4X20 UNI 5739	
69	-	NUT M4 UNI 7474	



COMPONENTI ELETTRICI 452-502-650 BT / 45-50 BTS 02
ELECTRIC COMPONENTS 452-502-650 BT / 45-50 BTS
COMPOSANTS ELECTRIQUES 452-502-650 BT / 45-50 BTS
ELEKTROTEILE 452-502-650 BT / 45-50 BTS
COMPONENTES ELECTRICOS 452-502-650 BT / 45-50 BTS

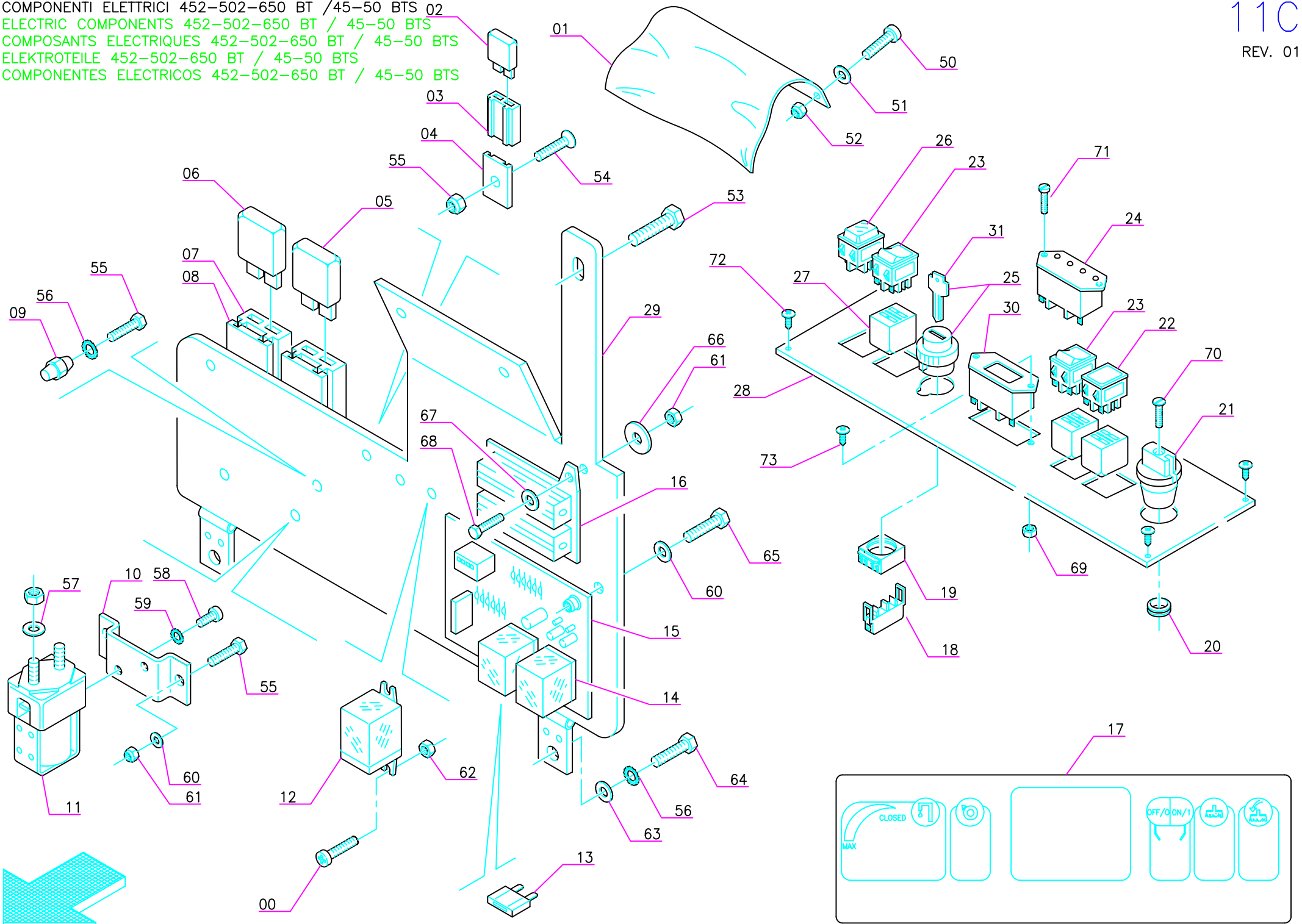

ITEM	SKU	DESCRIPTION	QTY
1	415152	PROTECTION	2
2	E83168	Fuse, 3 amp	1
3	E88244	Fuse Holder	1
4	409869	PLATE	1
5	E86196	Fuse, 60 amp	1
6	E83926	Fuse 30A faston suction motor	1
7	E81642	Fuseholder	2
8	E88497	Fuse Block End Cap	2
9	E83664	Insulator WS17	1
10	E83595	Remote control switch support	1
11	E83628	Contacto 24VDC	1
12	E83160	Relay 24VDC 30A	1
13	E83972	Fuse 30A fasten	1
14	E83159	Relay 24VDC 20A	2
15	E20646	Chopper Card	1
16	416025	RESISTANCE	2
17	413967	LABEL	1
18	E83173	Contact, Key Switch	1
19	E81358	Switch Flange	1
20	E87975	Stud Bolt Tripla	1
21	E86145	Knob	1
22	E81706	Signal Lamp Green	1
23	E83328	Vacuum switch	2
24	E88022	Battery Check Card 24 Volt	1
25	E83316	Key Switch	1
26	E88305	Cover, Black	1
27	409296	BASE	3
28	203524	SHEET	1

ITEM	SKU	DESCRIPTION	QTY
29	203526	PANNEL	1
30	E83495	Hour Meter	1
31	E83315	Switch Key	1
50	-	SCREW M4X10 UNI7687	-
51	-	WASHER M4 D.12 UNI 6593	-
52	-	NUT M4 UNI 7474	-
53	-	SCREW Ø 5,5X10 UNI 6954	-
54	-	SCREW M4X12 UNI 7688	-
55	-	SCREW M5X12 UNI5739	-
56	-	WASHER M5 DIN 6798/A	-
57	-	WASHER M8 UNI 6592	-
58	-	SCREW M4X6 UNI 7687	-
59	-	WASHER M4 DIN 6798/A	-
60	-	WASHER M5 UNI 6592	-
61	-	NUT M5 UNI 7474	-
62	-	NUT M4 UNI 5588	-
63	-	WASHER M5 D.15 UNI 6593	-
64	-	SCREW M5X16 UNI 5739	-
65	-	SCREW M5X12 UNI 5739	-
66	-	WASHER M5 D.20 UNI 6593	-
67	-	WASHER M5 D.15 UNI 6593	-
68	-	SCREW M5X30 UNI 5739	-
69	-	NUT M3 UNI 7474	-
70	-	SCREW M4X8 UNI 7688	-
71	-	SCREW M3X16 UNI 7687 A2	-
72	-	SCREW Ø 4,8X13 UNI 6954	-
73	-	SCREW Ø 4,2X13 UNI 6954	-



ITEM	SKU	DESCRIPTION	QTY
1	E81477	Knob 25X50 M8	2
2	203506	HANDLE	1
3	E82550	Handle - Lever S42	1
4	414726	BUSHING	2
5	203497	LEVER	1
6	E85768	Squeegee Cable	1
7	E81907	Pin	3
8	203505	SHAFT	1
9	202458	SPACER	1
10	415138	CABLE	1
11	E86154	Fork	1
12	415154	CABLE	1
13	E86154	Fork	1
14	203499	BRACKET	1
15	409392	PIN	1
50	-	NUT M6 UNI 7474	-
51	-	SCREW M6X16 UNI 5739	-
52	-	SCREW M6X30 UNI 5739	-
53	-	WASHER M6 DIN 6798/A	-
54	-	SCREW M6X20 UNI 5739	-
55	-	NUT M6 UNI 5588	-
56	-	SCREW M6X20 UNI 5739	-
58	-	WASHER M6 D.18 UNI 6593	-
59	-	NUT M5 UNI 5589	-
60	-	WASHER M5 DIN 6798/A	-
61	-	WASHER M5 D.15 UNI 6593	-



GRUPPO MOTORE ASPIRAZIONE B-BT / BS-BTS
 SUCTION MOTOR ASSEMBLY B-BT / BS-BTS
 GROUPE DE MOTEUR D'ASPIRATION B-BT / BS-BTS
 SAUGMOTORGRUPPE B-BT / BS-BTS
 GRUPE DE MOTOR DE ASPIRACION B-BT / BS-BTS

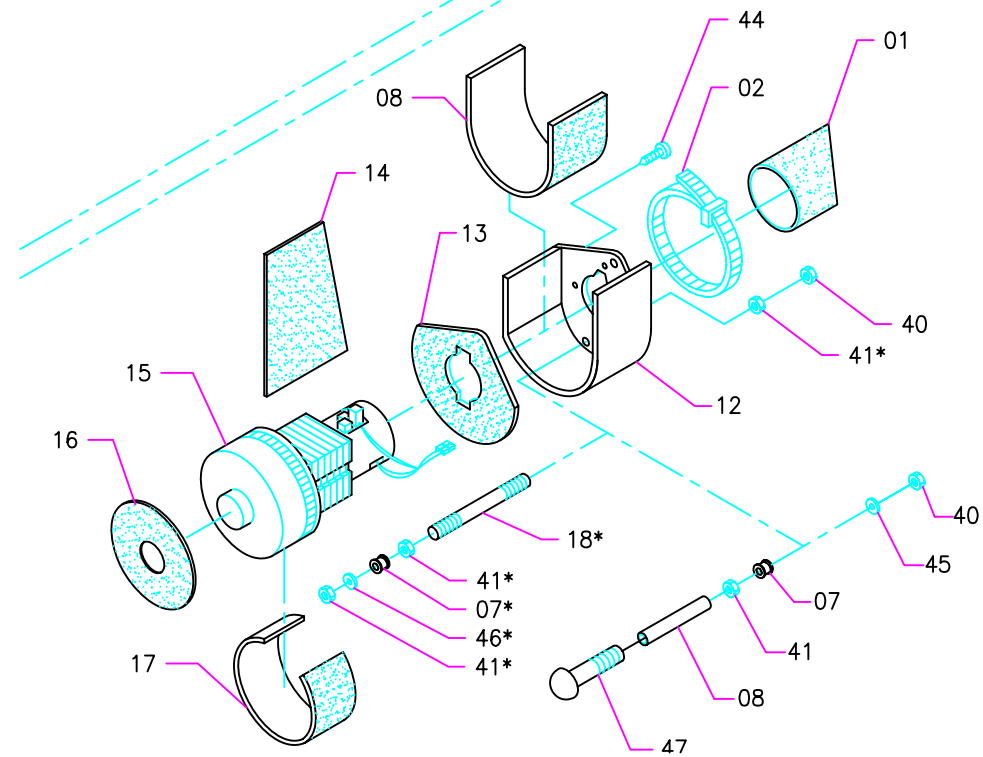
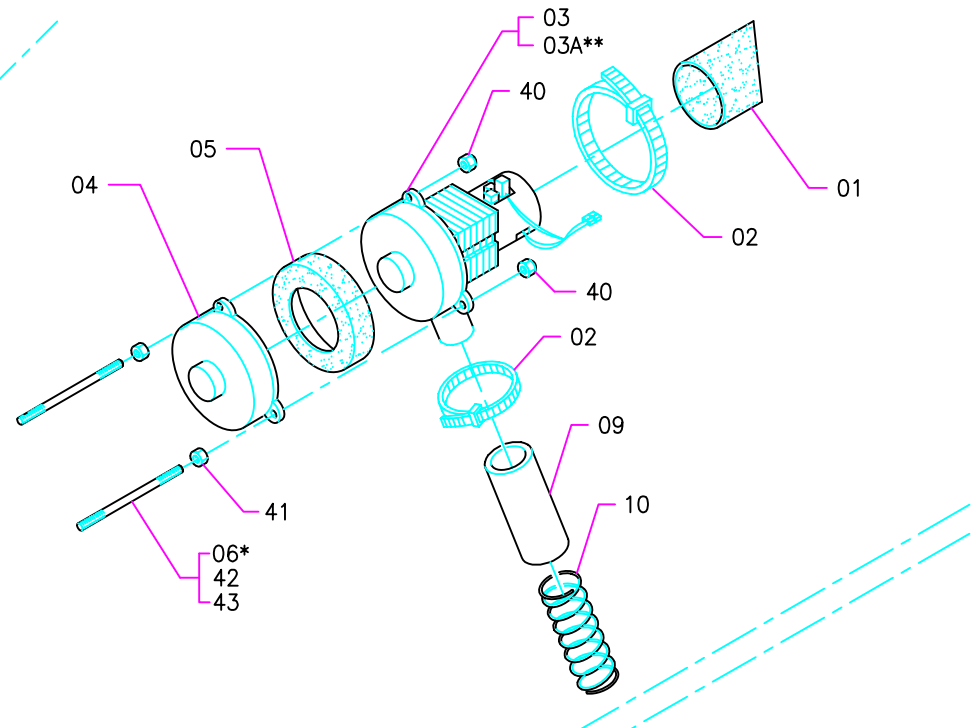
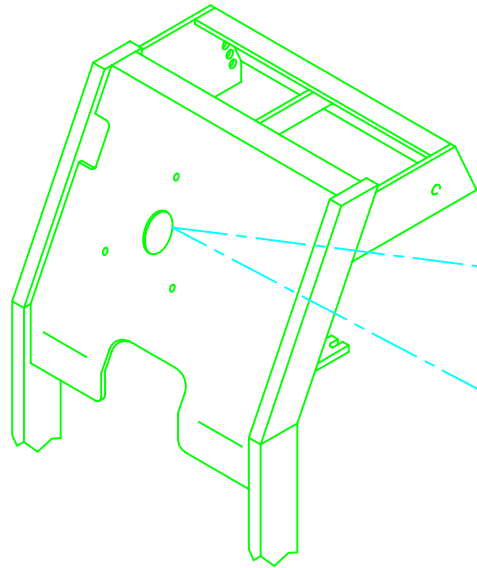

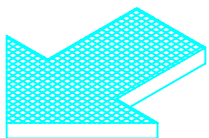

*	→	10/2002
**	→	06/2003



ITEM	SKU	DESCRIPTION	QTY
1	202243	DEADENING HOSE	1
2	E83920	Clamp 9x300 4,8x360 black	1
3	E83949	Motor, Vacuum	1
3A	E82631	Motor, Vacuum 36v 720w 2-Stage	1
4	414960	SUPPORT	1
5	E83944	Sound Deadening Foam	1
6	415134	STUD BOLT	3
7	E87975	Stud Bolt Tripla	3
8	414686	SPACER	3
9	E83244	deadenng hose	1
10	E83871	Compression spring 55x2x200	1
11	414350	DEADENING HOSE	1
12	203523	COVER	1
13	414352	DEADENING HOSE	1
14	414351	DEADENING HOSE	1
15	E88291	Vacuum Motor 36VDC 550W	1
16	E83944	Sound Deadening Foam	1
17	E82282	Sound Deadening Foam	1
18	206225	STUD BOLT	3
40	-	NUT M6	-
41	-	NUT M6	-
42	-	SCREW M6X80	-
43	-	SCREW M6X120	-
44	-	SCREW	-
45	-	WASHER M6 D.18	-
46	-	WASHER M6	-
47	-	SCREW M6x90	-

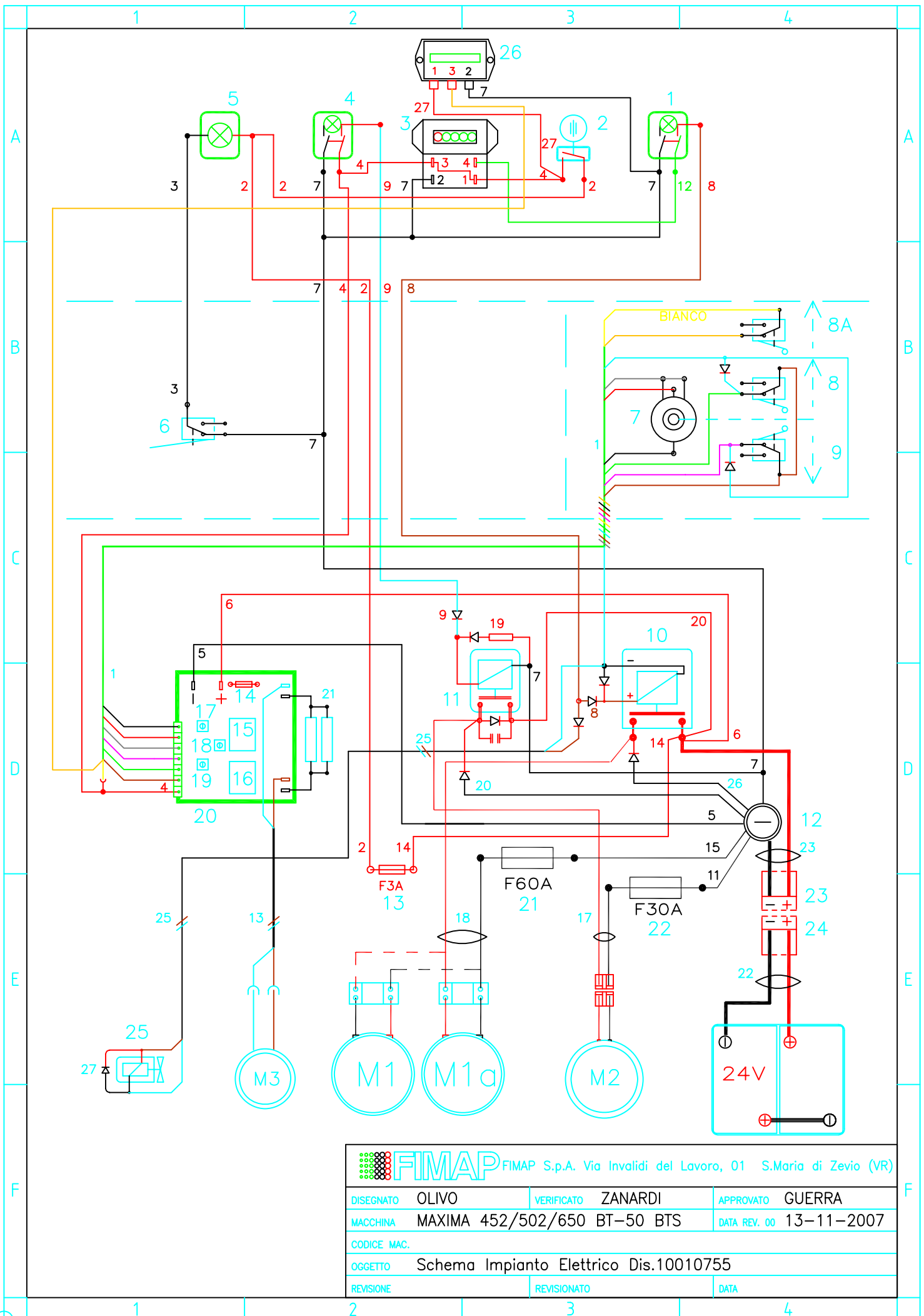



 FIMAP FIMAP S.p.A. Via Invalidi del Lavoro, 01 S.Maria di Zevio (VR)		
DISEGNATO OLIVO	VERIFICATO ZANARDI	APPROVATO GUERRA
MACCHINA MAXIMA 452/502/650 BT-50 BTS		DATA REV. 00 13-11-2007
CODICE MAC.		
OGGETTO Schema Impianto Elettrico Dis.10010755		
REVISIONE	REVISIONATO	DATA

ITEM	SKU	DESCRIPTION
1	E83328	Vacuum switch
2	E83316	Key Switch
3	E88022	Battery Check Card 24 Volt
4	E83328	Vacuum switch
5	E81706	Signal Lamp Green
6	E83164	Micro Switch
7	409448	POTENTIOMETER 2K
8	E82270	Micro Switch
9	E82270	Micro Switch
10	E83628	Contactactor 24VDC
11	E83160	Relay 24VDC 30A
12	E83664	Insulator WS17
13	E83168	Fuse, 3 amp
14	E83972	Fuse 30A faston
15	E83159	Relay 24VDC 20A
16	E83159	Relay 24VDC 20A
17	-	TRIMMER, MIN. SPEED
18	-	TRIMMER, ACCELERATION
19	-	TRIMMER, MAX. SPEED
20	E20646	Chopper Card
21	E86196	Fuse, 60 amp
22	E83926	Fuse 30A faston suction motor
23	E86208	SB50 Red Electrical Connector
24	E86208	SB50 Red Electrical Connector
25	407885	SOLENOID VALVE (OPT.)
26	E83495	Hour Meter
M1	E82810	Motor, Brush 3500 RPM, 24 V, 600 W
M1a	E88444	Brush Motor Drive
M2	E83949	Motor, Vacuum
M2	E82631	Motor, Vacuum 36v 720w 2-Stage
M2	E88291	Vacuum Motor 36VDC 550W
M3	414603	TRACTION MOTOR 24V



BETCO US WARRANTY POLICY

10 year coverage

Subject to the conditions stated below, Betco warrants parts and labor on rotationally molded polyethylene tanks/housings and injection molded vacuum head assemblies to be free from defects in materials and workmanship for a period of ten years to the original purchaser.

3 Year Coverage

Subject to the conditions stated below, Betco warrants parts and labor on all other Betco components to be free from defects in materials and workmanship for a period of three years to the original purchaser.

1 Year Coverage

Subject to the conditions stated below, Betco offers a limited warranty on parts and labor on the following equipment: parts and accessories to be free from defects in materials and workmanship for a period of one year to the original purchaser.

- DM Series Vacuums: #85506-00, #85507-00
- Bac Pac Lite Vacuum: #85903-00
- FiberPRO® Floor Dryer: #85507-00
- WORKMAN™ Series Vacuums: #85024-00, #85025-00, #85026-00, #85027-00
- CV100T Vacuum: #85023-00
- All Tools and Accessories
- All Battery Chargers
- All Batteries are pro-rated for 1 year

Allowable Travel Time Warranty Reimbursement:

Eligible equipment: All battery and propane powered equipment products. Warranty period: 90 days from date of sale to the original purchaser. A maximum 60 mile round trip at 44 cents per mile will be allowed for warranty consideration.

Propane Machine Warranty:

Honda engines are warranted by Honda for a period of 2 years against manufacturer defects. Kawasaki engines are warranted by Kawasaki for a period of 2 years against manufacturer defects. All other components (except wear items)* are warranted by Betco for a period of 3 years.

***Wear Items exempt from Warranty consideration include but may not be limited to: power cords, transport wheels, vacuum bags, belts, squeegee blades, pad drivers, clutch plates, handle grips, filters, screens, throttle cables, brushes and carbon brushes.**

Subject to the conditions and exceptions stated in this warranty, Betco warrants the Betco products to be free from defects in material and workmanship, under normal use and service, for the periods listed under the warranty policy to the original purchaser. At any time during the warranty period, Betco will furnish replacement parts for the Betco parts to the original purchaser. Such parts will be furnished and charged including transportation costs, to the original owner through any Betco authorized Service Distributor. If the original part is returned within the warranty policy period from date of delivery for inspection by Betco and is found to be defective the owner will be credited for the cost of replacement parts plus shipping and handling. Replacement parts that have become defective through wear or abuse are not included in this warranty.

This warranty does not apply to damage or defect caused by accident, misuse, negligence, fire, or to any Betco product which has been serviced or repaired by other than an authorized Betco Service Distributor or Betco factory personnel. This warranty is void if products are used for any purpose other than that which was intended. There are no other warranties expressed or implied. In no event shall Betco be liable for incidental or consequential damages or any damage to person or property. (Please note some states do not allow the exclusion or limitations for incidental and consequential damages)



1001 Brown Avenue • Toledo, Ohio 43607-0127

Customer Service: 888-GO-BETCO • Fax: 800-445-5056 • Technical Service: 877-856-5954 • www.betco.com

E87028-00 June10C