

WS28

ORDER #87301

Betco Watchman™ 28 Automatic Scrubber

FEATURES

- Simple design for easy operation
- Large tank capacity increases productivity
- Easy access parts design
- Heavy duty squeegee assembly
- Built durable for maximum performance
- Self propelled forward and reverse

The Betco Watchman™ series of automatic scrubbers brings a new dimension to cleaning maintenance. A simple design makes the WS28 easy to operate and reduces operator training. The 28" cleaning path along with the 24 gallon solution and recovery tanks increase productivity. A heavy-duty squeegee assembly and adjustable brush pressure provide maximum cleaning performance. Easy access to all areas of the machine reduces service down time. Betco's Watchman™ Automatic Scrubbers are built durable to last and will help make your cleaning maintenance jobs easier!

WARRANTY

Tank: 10 Year

Other components: 3 Year*

*Please refer to Betco Equipment Price/Product Guide for complete equipment warranty information.



SPECIFICATIONS

- Cleaning path: 28"
- Pad Drivers: (2) 14"
- Drive Motor: .3 hp
- Brush motors: (2) .75 hp
- Brush pressure: 0 - 150 adjustable
- Brush speed: 200 rpm
- Solution control: gravity feed - adjustable
- Solution tank: 24 gallon
- Recovery tank: 24 gallon
- Volts: 24 volt system
- Weight: 712 lbs. w/o batteries
1000 lbs. w/batteries
- Tires: (2) 11" pneumatic
- Dimensions: Length 61"
Width 28"
Height 41.5"

APPLICATIONS

- General Cleaning
- Heavy Duty Scrubbing
- Stripping

Authorized Betco Distributor:

Better Resources. Better Results.
BETCO®

1001 Brown Avenue • P.O. Box 3127 • Toledo, Ohio 43607-0127
©All Rights Reserved 10/99 • Reorder #87301 • email@betco.com • www.betco.com

BETCO BETTER SOLUTIONS

OFFERING THE TOTAL SOLUTION.

Betco is now the only manufacturer with a complete line of products for the cleaning professional.



Complete Floor Machine, Vacuum and Scrubber Line.



Complete Carpet Care Program.



Complete Training Programs.



Complete Chemical Programs, Cleaners, Floor Care and specialties.



Complete Hand Cleaner Line.



Nationwide Support.

Let Betco be your single source manufacturer.

Better Solutions Come From...
BETCO®

WATCHMANTM

BETCO.

WALK BEHIND SCRUBBER

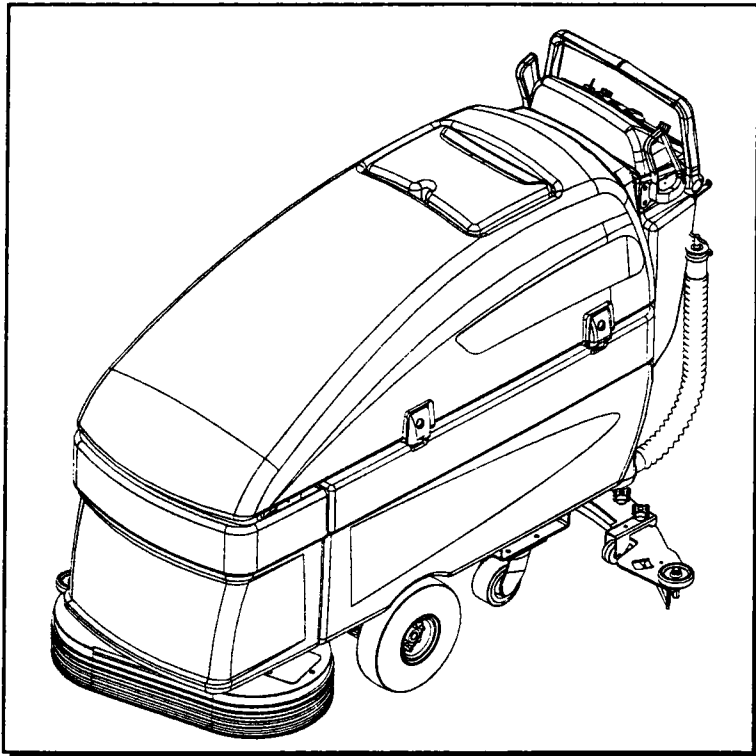

Operating Instructions

MODELS: BSS428
BSS432

Read these instructions before using the machine

A

MACHINE DATA LOG/OVERVIEW

MODEL _____

DATE OF PURCHASE _____

SERIAL NUMBER _____

SALES REPRESENTATIVE # _____

DEALER NAME _____

OPERATIONS GUIDE NUMBER _____

PUBLISHED _____

TABLE OF CONTENTS

<i>Machine Data Log/Overview</i>	2
<i>Table of Contents</i>	3

HOW TO USE THIS MANUAL

<i>How to use this Manual</i>	4
-------------------------------------	---

SAFETY

<i>Important Safety Instructions</i>	5
<i>Hazard Intensity Level</i>	6
<i>Safety Label Location</i>	7

OPERATIONS

<i>Technical Specifications</i>	8
<i>How the Machine Works</i>	10
<i>Controls</i>	11
<i>Machine Operation</i>	14
<i>Pre-Run Machine Inspection</i>	14
<i>Starting Machine</i>	14
<i>Emergency Stop Procedures</i>	14
<i>Filling the Solution Tank</i>	14
<i>Scrubbing</i>	14
<i>Emptying & Cleaning Tanks</i>	15

MAINTENANCE

<i>Batteries</i>	16
<i>Battery Maintenance</i>	16
<i>Checking Battery Specific Gravity</i>	16
<i>Charging the Batteries</i>	17
<i>Changing Batteries</i>	17
<i>Battery Connections</i>	17
<i>Scrub Brushes</i>	18
<i>Types</i>	18
<i>Replacing or Installing Scrub Brushes</i>	18
<i>Squeegee Blades</i>	19
<i>Adjusting Squeegee</i>	19
<i>Replace or Rotate Rear Squeegee Blade</i>	19
<i>Replace or Rotate Front Squeegee Blade</i>	19
<i>Adjusting Squeegee Pitch</i>	20
<i>Adjusting Rear Deflection</i>	20
<i>Scrub Deck Skirt/Squeegee Blades</i>	20
<i>Tires & Wheels</i>	20
<i>Service Schedule</i>	21

GROUP PARTS LIST

<i>Control Handle Group</i>	22
<i>Control Tower Group</i>	24
<i>Decal Group</i>	26
<i>Electrical Panel Group</i>	28
<i>Front Cover Group</i>	30
<i>Recovery Tank Group</i>	32
<i>Scrub Brush/Pad Driver Group – 32in.</i>	34
<i>Scrub Brush/Pad Driver Group – 28in.</i>	36
<i>Scrub Head Group – 28in.</i>	38
<i>Scrub Head Group – 32in.</i>	40
<i>Scrub Head Lift Group</i>	42
<i>Solution Tank Group</i>	44
<i>Squeegee Group – 28in Scrub Head</i>	46
<i>Squeegee Lift Group</i>	48
<i>Vacuum Group</i>	50
<i>Wheels and Frame Group</i>	52
<i>Wiring Group – Battery Cables</i>	54
<i>Wiring Group – Control Panel</i>	56
<i>Wiring Group – Main Harness</i>	58
<i>Wiring Group – Schematic</i>	60
<i>Suggested Spare Parts/Notes</i>	61
<i>Option – Brake</i>	62
<i>Option – Emergency Stop</i>	64
<i>Option – Hour Meter</i>	66
<i>Option – Quick Scrub Head Connect</i>	68
<i>Option – Smart Squeegee 24in & 26in</i>	70
<i>Option – Smart Squeegee 28in</i>	72

HOW TO USE THIS MANUAL

This manual contains the following sections:

- HOW TO USE THIS MANUAL
- SAFETY
- OPERATIONS
- MAINTENANCE
- PARTS LIST

The HOW TO USE THIS MANUAL section will tell you how to find important information for ordering correct repair parts.

When placing an order for parts, the machine model and machine serial number are important. Refer to the MACHINE DATA box which is filled out during the installation of your machine. The MACHINE DATA box is located on the inside of the front cover of this manual.

MODEL _____
DATE OF PURCHASE _____
SERIAL NUMBER _____
SALES REPRESENTATIVE # _____
DEALER NAME _____
OPERATIONS GUIDE NUMBER _____
PUBLISHED _____

The model and serial number of your machine is on the bottom back-end of the machine.

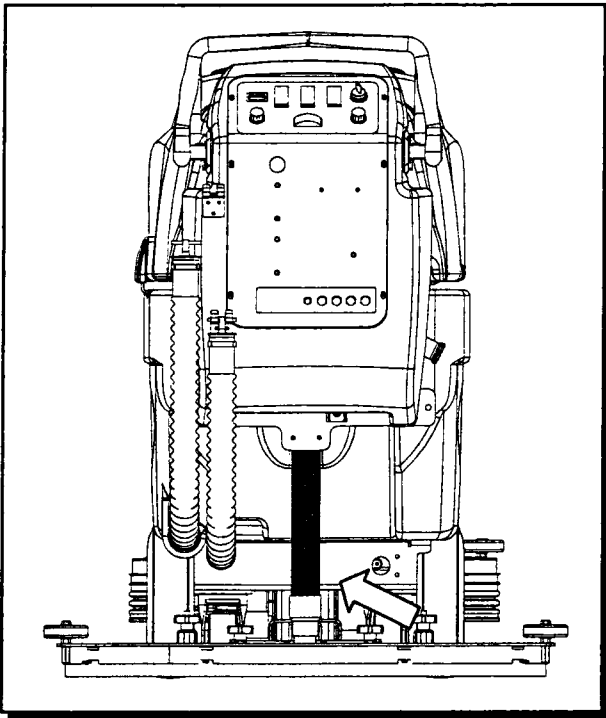

The SAFETY section contains important information regarding hazard or unsafe practices of the machine. Levels of hazards are identified that could result in product or personal injury, or severe injury resulting in death.

The OPERATIONS section is to familiarize the operator with the operation and function of the machine.

The MAINTENANCE section contains preventive maintenance to keep the machine and its components in good working condition. They are listed in this general order:

- Batteries
- Scrub Brushes
- Adjusting Squeegee
- Scrub Deck Skirt
- Squeegee Blade/Brush Head Options
- Service Schedule

The PARTS LIST section contains assembled parts illustrations and corresponding parts list. The parts lists include a number of columns of information:

- **REF** – column refers to the reference number on the parts illustration.
- **PART NO.** – column lists the part number for the part.
- **QTY** – column lists the quantity of the part used in that area of the machine.
- **DESCRIPTION** – column is a brief description of the part.
- **SERIAL NO. FROM** – column indicates the first machine the part number is applicable to. When the machine design has changed, this column will indicate serial number of applicable machine. The main illustration shows the most current design of the machine. The boxed illustrations show older designs.
- **NOTES** – column for information not noted by the other columns.

(NOTE: If a service or option kit is installed on your machine, be sure to keep the KIT INSTRUCTIONS which came with the kit. It contains replacement parts numbers needed for ordering future parts.)

IMPORTANT SAFETY INSTRUCTIONS

When using an battery powered appliance, basic precaution must always be followed, including the following:

READ ALL INSTRUCTIONS BEFORE USING THIS MACHINE.



To reduce the risk of fire, electric shock, or injury:

Use only indoors. Do not use outdoors or expose to rain.

Use only as described in this manual. Use only manufacturer's recommended components and attachments.

If the machine is **not working properly**, has been dropped, damaged, left outdoors, or dropped into water, return it to an authorized service center.

Do not operate the machine with any openings blocked. Keep openings free of debris that may reduce airflow.

This machine is **not** suitable for picking up hazardous dust.

Machine can cause a fire when operating near flammable vapors or materials. Do not operate this machine near flammable fluids, dust or vapors.

This machine is suitable for commercial use, for example in hotels, schools, hospitals, factories, shops and offices for more than normal housekeeping purposes.

Maintenance and repairs **must be done** by qualified personnel.

If foam or liquid comes out of machine, **switch off immediately.**

Disconnect battery before cleaning or servicing.

Before the machine is discarded, the batteries **must be removed** and properly disposed of.

Make sure all warning and caution labels **are legible and properly attached** to the machine.

During operation, attention shall be paid to other persons, especially children.

Before use all covers and doors shall be put in the positions specified in the instructions.

When leaving unattended, secure against unintentional movement.

The machine shall only be operated by instructed and authorized persons.

When leaving unattended, switch off or lock the main power switch to prevent unauthorized use.

Only chemicals recommended by the manufacturer shall be used.

This appliance has been designed for use with the brushes specified by the manufacturer. The fitting of other brushes may affect its safety.

Do not use on surfaces having a gradient exceeding 2% unless the optional parking brake is installed on the machine.

SAVE THESE INSTRUCTIONS

HAZARD INTENSITY LEVEL

The following symbols are used throughout this guide as indicated in their descriptions:

HAZARD INTENSITY LEVEL

There are three levels of hazard intensity identified by signal words -**WARNING** and **CAUTION** and **FOR SAFETY**. The level of hazard intensity is determined by the following definitions:

⚠ WARNING

WARNING - Hazards or unsafe practices which **COULD** result in severe personal injury or death.

⚠ CAUTION

CAUTION - Hazards or unsafe practices which could result in minor personal injury or product or property damage.

FOR SAFETY: To identify actions which must be followed for safe operation of equipment.

Report machine damage or faulty operation immediately. Do not use the machine if it is not in proper operating condition. Following is information that signals some potentially dangerous conditions to the operator or the equipment. Read this information carefully. Know when these conditions can exist. Locate all safety devices on the machine. Please take the necessary steps to train the machine operating personnel.

FOR SAFETY:

DO NOT OPERATE MACHINE:

Unless Trained and Authorized.

Unless Operation Guide is Read and understood.

In Flammable or Explosive areas.

In areas with possible falling objects.

WHEN SERVICING MACHINE:

Avoid moving parts. Do not wear loose clothing; jackets, shirts, or sleeves when working on the machine. Use manufacturer approved replacement parts.

⚠ WARNING

Batteries emit hydrogen gas. Explosion or fire can result. Keep sparks and open flame away. Keep solution tank in raised position when charging. Keep sparks and flames away from the batteries. Do not smoke around batteries.

⚠ WARNING

Disconnect batteries before working on machine. Only qualified personnel should work inside machine. Always wear eye protection and protective clothing when working on or near batteries. Avoid skin contact with the acid contained in the batteries.

⚠ WARNING

Never allow metal to lie across battery tops.

SAFETY LABEL LOCATION

NOTE: These drawings indicate the location of safety labels on the WATCHMAN™. If at any time the labels become illegible, promptly replace them.



SAFETY DECAL 81494

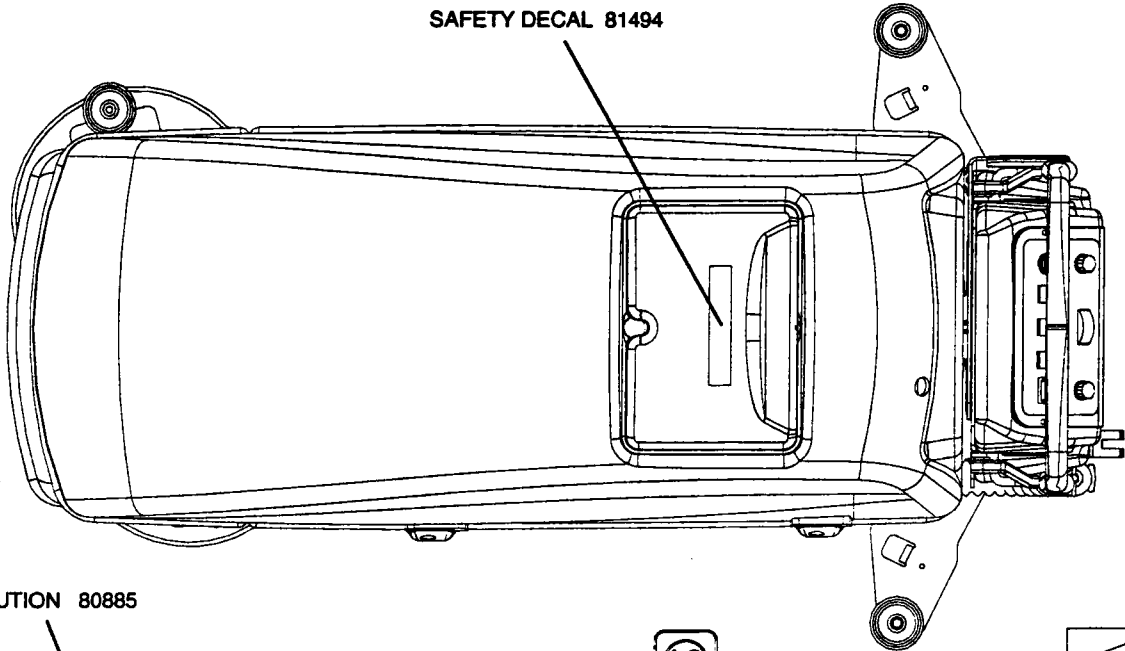

BATTERY CAUTION 80885



MANUAL DECAL 50776

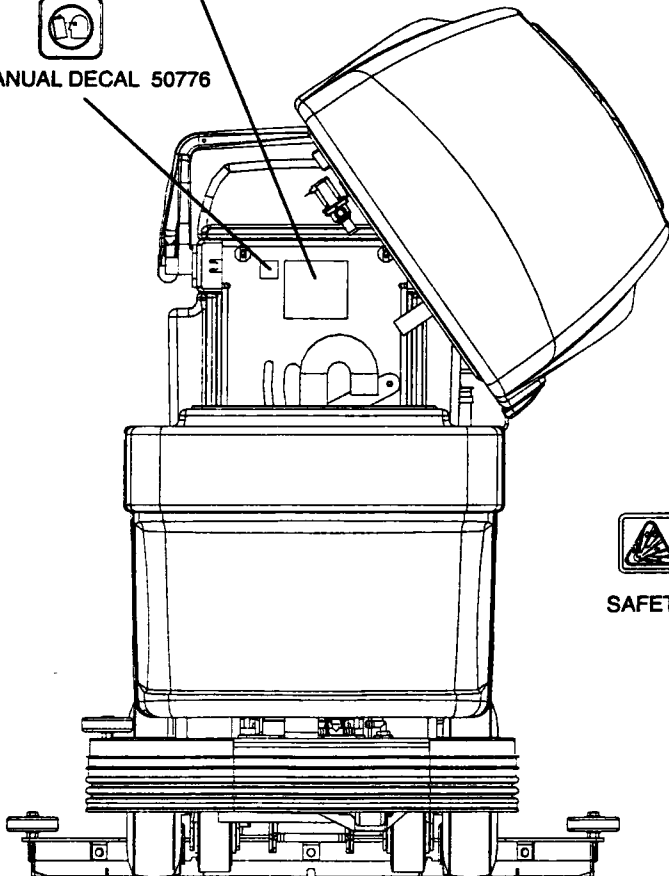

MANUAL DECAL 50776



2% GRADE DECAL 50926

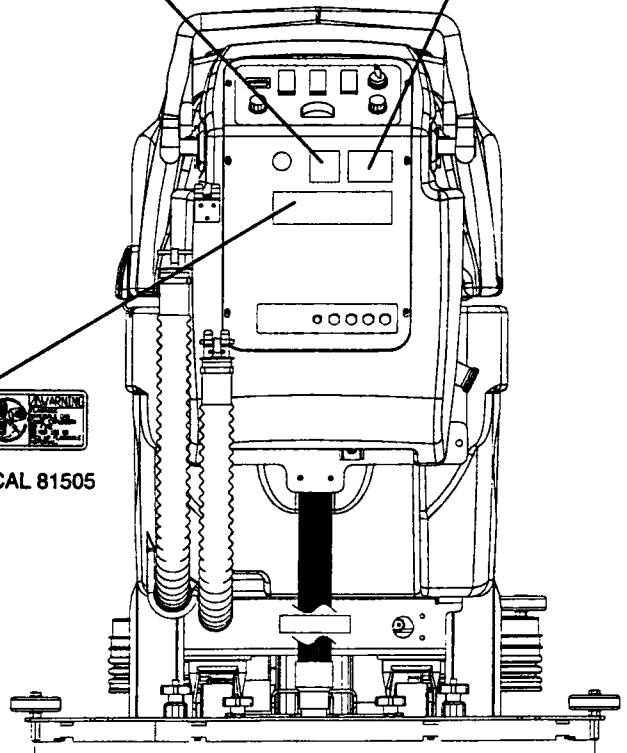

SAFETY DECAL 81505

TECHNICAL SPECIFICATIONS

ITEM	DIMENSION/CAPACITY
Nominal power	1.44 kW
Rated Voltage	24VDC
Rated Amperage	60 Amps
Batteries	4 X 6 Volt 250-305 AH @ 20 hr rate
Scrub Brush Motors	2 X .75 hp (0.56 Kw)
Vacuum Motor	.75 hp (0.56 Kw)
Propelling Motor	.3 hp (0.22 Kw)
Mass (GVW)	1050 lbs. (480 kg)
Weight empty without batteries	425 lbs. (192 kg)
Solution Control	Gravity feed, fully variable with automatic shut-off in neutral
Solution tank capacity	21 gal. (79.5 l)
Recovery tank capacity	21 gal. (79.5 l)
Scrub brush diameter for 24 in. (61cm) scrub head	12 in (30.5 cm)
Scrub brush diameter for 26 in. (66 cm) scrub head	13 in (33.0 cm)
Scrub brush diameter for 28 in. (71 cm) scrub head	14 in (35.5 cm)
Scrub brush pressure	0-150 lbs. (0-68 kg)
Scrub brush speed	200 rpm
Tires	2 x 10 in (25.4 cm) pneumatic non-marking standard
Casters	2 X 4 in (10.2 cm) polyurethane solid non-marking
Foundation Pressure (at recommended tire psi)	32 lbs./in ² (225 kPa)
Maximum Speed	3.2 Miles/hour (5.2 km/hour)
Coverage with 24 in. (61 cm) scrub head	29,040 ft ² /hour at 3.0 mph with 2 in. overlap
Coverage with 26 in. (66 cm) scrub head	31,680 ft ² /hour at 3.0 mph with 2 in. overlap
Coverage with 28 in. (71 cm) scrub head	34,320 ft ² /hour at 3.0 mph with 2 in. overlap
Frame Construction	Welded cold rolled steel and steel plate with epoxy powdercoat finish.
Brakes (optional)	Tire lock parking brake, foot activated
Minimum aisle u-turn width with 24 in. (61 cm) scrub head	65 in. (165 cm)
Minimum aisle u-turn width with 26 in. (66 cm) scrub head	65.5 in. (166 cm)
Minimum aisle u-turn width with 28 in. (71 cm) scrub head	66 in. (168 cm)
Maximum rated climb and descent angle with empty tanks and without optional parking brake	2%
Maximum rated climb and descent angle with full tanks and without optional parking brake	2%

TECHNICAL SPECIFICATIONS

ITEM	MEASURE
Height	43.5 in. (110 cm)
Length with 24 in. (61 cm) scrub head	64 in. (163 cm)
Length with 26 in. (66 cm) scrub head	64.5 in. (164 cm)
Length with 28 in. (71 cm) scrub head	65 in. (165 cm)
Width without squeegee and scrub head	22 in. (56 cm)
Width of squeegee for 24 in. (61 cm) scrub head	36 in. (91 cm)
Width of squeegee for 26 in. (66 cm) scrub head	36 in. (91 cm)
Width of squeegee for 28 in. (71 cm) scrub head	39.5 in. (100 cm)
Width of scrub path for 24 in. (61 cm) scrub head	24 in. (61 cm)
Width of scrub path for 26 in. (66 cm) scrub head	26 in. (66 cm)
Width of scrub path for 28 in. (71 cm) scrub head	28 in. (71 cm)

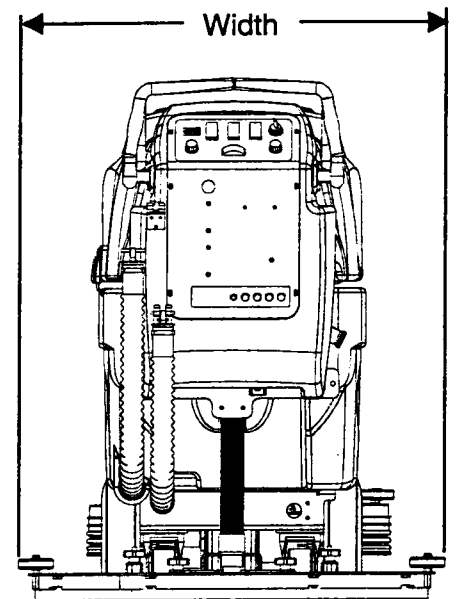
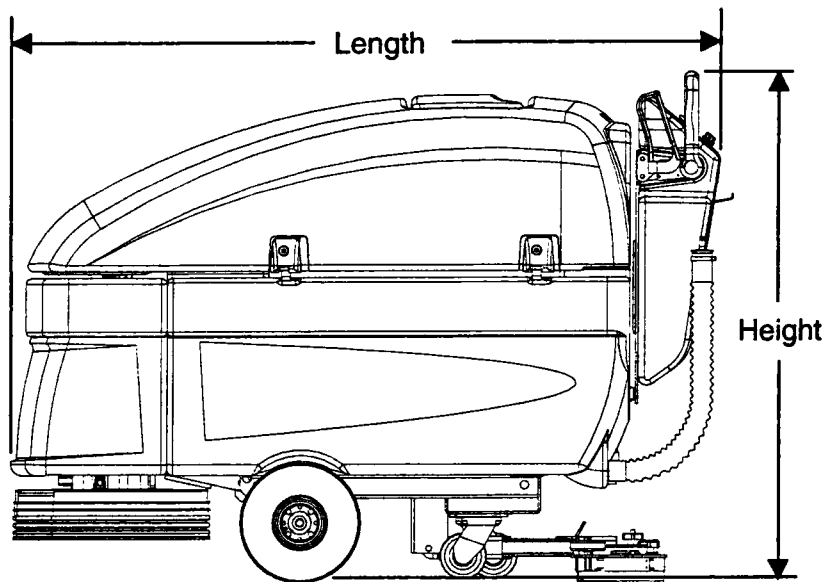

SPECIAL NOTES:

The sound pressure level at the operator's ear was measured to be 68 dBA. This was a nearfield, broad-band measurement taken in a typical industrial environment on a tile floor. This appliance contains no possible source of impact noise. The instantaneous sound pressure level is below 63 Pa.

The weighted root mean square acceleration at the operator's arms was measured to be below 2.5m/s^2 . This was a tri-axial, third-octave-band measurement made during normal operation on a composite tile floor. The measurement and related calculations were made in accordance with ANSI S3.34-1986.

HOW THE MACHINE WORKS

The *WATCHMAN™* is a battery powered, self-propelled, hard floor scrubber intended for commercial use. The appliance applies a cleaning solution onto a hard floor, scrubs the floor with brushes, and then vacuums the soiled water back into the recovery tank.

The machines primary systems are the solution system, scrub system, recovery system, and directional control system.

The function of the solution system is to store cleaning solution and deliver it to the scrub system. The solution system consists of the solution tank, strainer, valve and controls. The solution tank stores cleaning solution (water and detergent) until it is delivered to the scrub system. The strainer protects the valve from debris. The valve is a solenoid type valve, which controls the delivery of cleaning solution to the scrub system. The valve automatically prevents solution flow unless the scrub brushes are turned on and the machine is being propelled. The solution control knob controls the amount of cleaning solution delivered to the scrub system by controlling the amount of time the valve is open.

The function of the scrub system is to scrub the floor. The scrub system consists of two rotary type disk scrub brushes, motors, self-adjusting scrub deck skirt, lift actuator and controls. The brushes scrub the floor and the motors drive the brushes. The brush drive hubs allow the scrub brushes to follow irregularities and changes in the floor without losing contact with floor. The self-adjusting scrub deck skirt controls the cleaning solution on the floor so that the squeegee can pick it up. The brush pressure switch controls an actuator, which raises and lowers the scrub deck. The brush pressure indicator corresponds to the amp draw of the scrub brush motors to tell how hard they are working.

The function of the recovery system is to vacuum the soiled water back into the recovery tank. The recovery system consists of the squeegee, vacuum motor, filter, recovery tank and controls. The squeegee wipes the dirty solution off the floor as the machine moves forward. The vacuum motor provides suction to draw the dirty solution off the floor and into the recovery tank. The filter protects the vacuum fan from debris and foam. The recovery tank stores the dirty solution. The float switch in the tank activates the recovery tank full indicator and shuts off the vacuum motor.

The function of the directional control system is to control the direction and speed of the machine. The directional control system consists of the directional control lever, switches, speed control knob/potentiometer, controller and transaxle. The directional control lever actuates switches, which signal forward or reverse. The speed control knob actuates a potentiometer, which signals speed. The controller interprets the forward/reverse signals from the switches and the speed signal from the potentiometer to command the transaxle to propel the machine in the direction, and at the speed, desired.

CONTROLS

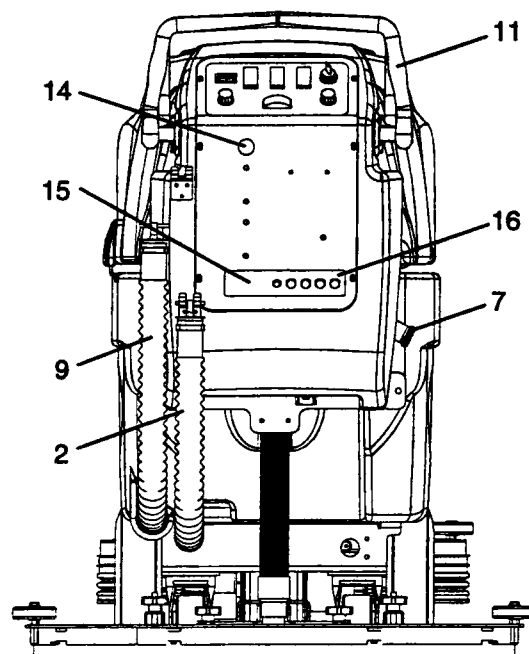
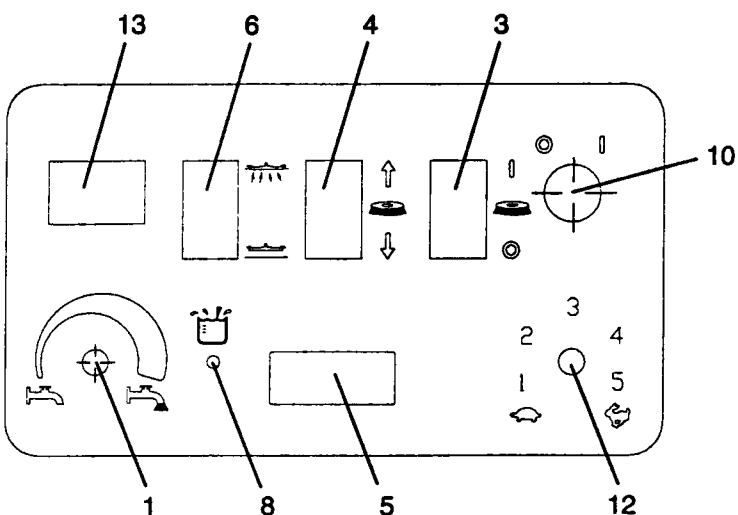

1. **Solution Control Knob**
2. **Solution Tank Drain Hose**
3. **Brush Switch**
4. **Brush Pressure Switch**
5. **Brush Pressure Indicator**
6. **Vacuum Switch**
7. **Squeegee Lift Lever**
8. **Recovery Tank Full Indicator**
9. **Recovery Tank Drain Hose**
10. **Key Switch**
11. **Direction Control Lever**
12. **Speed Control Knob**
13. **Battery Charge Level Indicator**
14. **Emergency Shut Off Switch (Optional)**
15. **Hour Meter (Optional)**
16. **Circuit Breakers**

CONTROLS

1. SOLUTION CONTROL KNOB

Controls solution flow to scrub deck. Rotate the knob clockwise to increase flow. Rotate the knob counterclockwise to decrease flow. If the brush motors are turned off or the direction control lever is in neutral, the flow is automatically interrupted until the motors are turned on again. This feature prevents unintentional draining of the solution tank and allows the operator to adjust the solution flow to the scrub deck without resetting each time the scrubbing operation is interrupted.

2. SOLUTION TANK DRAIN HOSE

Located at left rear of machine. Secured by clip and closed by expanding plug.

3. BRUSH SWITCH

Turns the scrub motors on and off. Press the top of the switch to turn on. Press the bottom of the switch to turn off. The brushes will not rotate with the direction control lever in neutral.

4. BRUSH PRESSURE SWITCH

Adjusts the amount of brush pressure to the floor by raising or lowering the scrub deck. Press the bottom of the switch to increase brush pressure. Press the top of the switch to decrease brush pressure or raise the scrub deck.

5. BRUSH PRESSURE INDICATOR

The brush pressure indicator corresponds to the amp draw of the scrub brush motors to tell how hard the motors are working. The green zone indicates proper operating brush pressure. The red zone indicates excessive brush pressure. Operating in the red zone will cause the brush circuit breakers to trip.

6. VACUUM SWITCH

Turns the vacuum motor on and off. Press the top of the switch to turn on. Press the bottom of the switch to turn off. The vacuum motor will not operate with the recovery tank full indicator light on.

7. SQUEEGEE LIFT LEVER

Raises and lowers the squeegee. Lift the handle from its raised position to lower the squeegee. Lift the handle from its lowered position to raise the squeegee.

8. RECOVERY TANK FULL INDICATOR

Will light when the float switch indicates a full recovery tank. The vacuum motor will not operate with recovery tank full. The recovery tank must be drained and the vacuum switch or key switch turned off before the indicator light will turn off.

9. RECOVERY TANK DRAIN HOSE

Located at left rear of machine. Secured by clip and closed by expanding plug.

10. KEY SWITCH

Controls the power for machine functions. Rotate the key clockwise to turn on the machine. Rotate the key counterclockwise to turn off the machine.

FOR SAFETY: Always remove the key when machine is unattended or during service to prevent unauthorized movement.

11. DIRECTION CONTROL LEVER

Controls the machine direction, and scrub brushes and solution flow. Push the lever forward to propel the machine forward. Pull the lever toward you to propel the machine backward. The scrub brushes will not rotate and the solution will not flow to scrub deck with the direction control lever in neutral.

12. SPEED CONTROL KNOB

Controls the speed of the machine. Rotate the knob clockwise to increase speed. Rotate the knob counterclockwise to decrease speed.

13. BATTERY CONDITION METER

The battery condition meter indicates the charge level of the battery. The meter display is divided into 10 vertical bars. Bars illuminated on the far right indicate full charge. Bars flashing near the left side indicate the batteries should be recharged. Further operation of the machine could damage the machine or the batteries.

When the machine is left overnight with less than a full charge, the display may initially indicate a full charge. It will also indicate a full charge if the batteries are disconnected, then reconnected. After a few minutes of operation the meter will give the correct charge level.

14. EMERGENCY SHUT-OFF SWITCH (OPTIONAL)

Shuts off machine. Push the switch to shut off machine. Rotate the switch clockwise to restart machine.

15. HOUR METER (OPTIONAL)

Records the number of hours the machine has been in operation. This information is useful in determining when to service the machine.

16. CIRCUIT BREAKERS

Circuit breakers interrupt the flow of power in the event of an electrical overload. When a circuit breaker is tripped, reset it by pressing the exposed button. If a circuit breaker continues to trip, the cause of the electrical overload should be found and corrected.



3 Amp. Protects the machine controls and scrub deck lift actuator.



30 Amp. Protects the left scrub brush motor.



30 Amp. Protects the right scrub brush motor.



25 Amp. Protects the vacuum motor.



25 Amp. Protects the propel motor.

MACHINE OPERATION

PRE-RUN MACHINE INSPECTION

Do a pre-run inspection to find possible problems that could cause poor performance or lost time from breakdown. Follow the same procedure each time to avoid missing steps.

NOTE: See maintenance section for pre-run machine inspection checklist items.

STARTING MACHINE

NOTE: Perform pre-run machine check before operating machine.

FOR SAFETY: Before starting machine, make sure that all safety devices are in place and operating properly.

1. Turn the machine power on.
2. Release the parking brake, if your machine is equipped with this option.
3. Move the direction control lever in the desired direction.

EMERGENCY STOP PROCEDURES

1. Release the directional control lever.
2. Turn machine power off with key switch.
3. If an electrical problem is suspected push in emergency stop button, if machine is equipped with this option.
4. Apply brakes, if your machine is equipped with this option.

FILLING SOLUTION TANK

FOR SAFETY: Before leaving or servicing machine; stop on level surface, turn off machine and remove key.

1. Turn the machine power off.
2. Set the parking brake if your machine is equipped with this option.
3. Remove solution tank cover.
4. Fill the solution tank with clean water, leaving enough room for the required amount of cleaning solution. The solution tank capacity filled to 5" (13cm) from bottom of fill inlet is 21 gallons (79.5 liters). The water must not be hotter than 140° F (60°C) to prevent damage to the tank.

5. **Measure** the chemical into the solution tank. Liquid chemicals should be added to the solution tank after filling with water. Dry chemicals should be thoroughly mixed before being added into solution tank. Commercially available, high alkaline floor cleaners, are suitable for use in the solution system.

NOTE: Read the chemical manufacturers recommended proportion instructions.

6. Replace solution tank cover.

WARNING

Flammable materials can cause an explosion or fire. Do not use flammable materials in the tanks.

NORMAL SCRUBBING

Plan the scrubbing pattern in advance. The longest track is around the perimeter of the area to be cleaned. For efficient operation, the runs should be the longest possible without turning, stopping, or raising and lowering scrub deck/squeegee.

NOTE: In order to achieve the best possible results, the area which is to be cleaned should be swept before scrubbing. Large debris, strings & wire must be removed to prevent being caught in brushes or squeegee.

INEFFICIENT SCRUBBING PATH

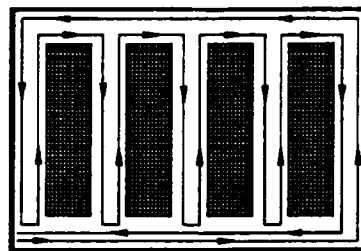

RECOMMENDED SCRUBBING PATH

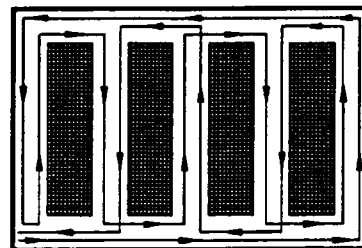

TO BEGIN SCRUBBING

▲ CAUTION

When operating the machine around people, pay close attention for unexpected movement. Use extra caution around children.

▲ WARNING

Flammable liquids and/or reactive metals can cause explosions or fire! Do not pick up.

1. Turn the machine power on.
2. Lower the squeegee.
3. Turn the vacuum on.
4. Lower the scrub brushes to the floor.
5. Turn the scrub brushes on (brushes will start when machine is propelled).
6. Drive machine forward to begin scrubbing.
NOTE: Shut machine off immediately if water or foam is expelled from the machine.
7. Adjust the speed of the machine, solution flow and scrub brush pressure as necessary.
NOTE: Once solution flow rate is set it is not necessary to shut off solution when stopping scrubbing. Solution flow is automatically shut off when brush motors stop. When brush motors are activated, flow automatically resumes.

TO STOP SCRUBBING

1. Release the directional control lever.
2. Turn the scrub brushes off.
3. Raise the scrub brushes.
4. Raise the squeegee.
5. Turn the vacuum off.
6. Turn the machine power off.

DOUBLE SCRUB

Floors which are heavily soiled or have thick accumulations of floor finish may not clean sufficiently with one pass. In these cases it will be necessary to double scrub.

To double scrub, make the first pass over the surface being cleaned with the squeegee up, the solution on, and brushes down. This allows the solution to stay in contact with the soil while loosening the surface accumulation with the brushes. Allow time for the first application to stay in contact with the floor. Length of time between the

first and second pass depends on amount of accumulation and the type of chemical being used. A second scrubbing with the squeegee down and again the solution and brushes on will further loosen soil. The additional application of solution will further assist the difficult cleaning job.

FOR SAFETY: When using machine, go slow on inclines and slippery services.

EMPTYING AND CLEANING TANKS

1. Park the machine next to a floor drain. Drain hose is on left rear corner of the machine.
2. Turn the machine power off and set parking brake, if your machine is equipped with this option.

SOLUTION TANK

1. Unhook the small drain hose from the retainer. Unscrew T-handle on plug enough to loosen plug, then lower hose in direction of the drain. Slowly remove plug from drain hose.
2. Remove the solution tank cover.
3. Flush the solution tank out with clean water and run several gallons of clean water through systems. Do not use water hotter than 140°F (60°C) to clean tank. Damage may occur.
NOTE: Never allow solution to remain in tank. Damage to tank, seals and valves could occur.
4. Replace the drain plug and secure drain hose in bracket.

RECOVERY TANK

1. Unhook the large drain hose from the retainer. Unscrew the T-handle on plug enough to loosen plug, then lower hose in direction of the drain. Do not stand in front of end of hose. Recovered solution will come out with force. Slowly remove plug from drain hose.
2. Raise solution tank to access recovery tank. Make sure the support arm is fully engaged. Flush the recovery tank out with clean water. Do not use water hotter than 140°F (60°C) to clean tank. Damage may occur.
3. Clean off the float switch and check for free movement of float. The float switch is located in the front of the recovery tank.
4. Replace the drain plug and secure drain hose in bracket.
5. If machine is to be stored, leave solution tank in raised position.

MAINTENANCE

BATTERIES

The batteries provide the power to operate the machine. The batteries require regular maintenance to keep them operating at peak efficiency.

The machine batteries will hold their charge for long periods of time, but they can only be charged a certain number of times. To get the greatest life from the batteries, charge them when their charge level reaches 25% of a full charge. Use a hydrometer to check the charge level.

Do not allow the batteries to remain in a discharged condition for any length of time. Never expose a discharged battery to temperatures below freezing. Discharged batteries will freeze causing cracked cases. Do not operate the machine if the batteries are in poor condition or if they have a charge level below 25% (specific gravity below 1.155).

Keep all metallic objects off the top of the batteries, as they may cause a short circuit. Replace worn or damaged cables and terminals.

Check the electrolyte level in each battery cell before and after charging the batteries. Never add acid to the batteries, use distilled water. Do not allow water level to fall below the battery plates. Portions of plates exposed to air will be destroyed. Do not overfill. Keep plugs firmly in place at all times.

▲ CAUTION

When servicing machine, avoid contact with battery acid.

▲ WARNING

Batteries emit hydrogen gas. Explosion or fire can result. Keep sparks and open flame away. Keep covers open when charging.

▲ WARNING

Wear eye protection and protective clothing when working with batteries.

▲ WARNING

Charge batteries in a well ventilated area.

BATTERY MAINTENANCE

1. When cleaning the batteries, use a solution of baking soda and water. Do not allow the cleaning fluid to enter the battery cells, electrolyte will be neutralized.
2. Maintain the proper electrolyte level in each battery cell. If a cell should accidentally overflow, clean immediately.

3. Wipe off the top of the batteries at least once a week.
4. Test battery condition with a hydrometer at least once a week.
5. Ensure that all connections are tight and all corrosion removed.
6. Every 4 to 6 months, remove that batteries from the machine and clean the battery cases and battery compartment.

CHECKING BATTERY SPECIFIC GRAVITY

Use a hydrometer to check the battery specific gravity.

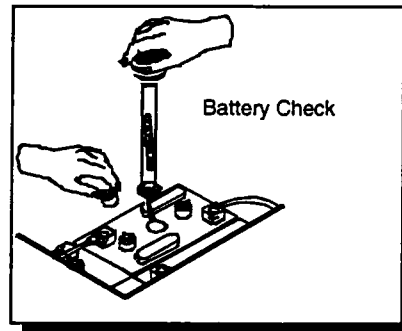

CHECKING GRAVITY

A. Hydrometer

B. Battery

NOTE: Do not take readings immediately after adding distilled water, if the water and acid are not thoroughly mixed, the reading may not be accurate.

Check the hydrometer readings against this chart.

SPECIFIC GRAVITY @ 80° F (27°C)	BATTERY CONDITION
1.265	100% CHARGED
1.225	75% CHARGED
1.190	50% CHARGED
1.155	25% CHARGED
1.120	DISCHARGED

NOTE: If the readings are taken when the battery electrolyte is any temperature other than 80° F (27°C), the reading must be temperature corrected.

To find the corrected specific gravity reading when the temperature of the battery electrolyte is other than 80°F (27°): Add (+) to the specific gravity reading 0.004 (4 points), for each 10°F (6°C) above 80° (27°C).

Subtract (-) from the specific reading 0.004 (4 points), for each 10°F (6°C) below 80°F (27°C).

TO CHARGE THE BATTERIES

⚠ CAUTION

When servicing machine, avoid contact with battery acid.

⚠ WARNING

Batteries emit hydrogen gas. Explosion or fire can result. Keep sparks and open flame away. Keep covers open when charging.

⚠ WARNING

Wear eye protection and protective clothing when working with batteries.

⚠ WARNING

Charge batteries in a well ventilated area. Leave the solution tank open.

Use a 24 volt, 20 amp maximum output, DC charger which will automatically shut off when the batteries are fully charged to charge the four battery pack.

1. Stop the machine in a clean, well ventilated area next to the charger.
2. Turn "OFF" machine.

FOR SAFETY: Before leaving or servicing machine; stop on level surface, turn off machine and remove key.

3. Drain solution tank and raise the solution tank and lock the support arm. Make sure the support arm is fully engaged.

⚠ WARNING

Batteries emit hydrogen gas. Explosion or fire can result. Keep sparks and open flame away. Keep covers open when charging.

4. Check the electrolyte level in each battery cell. Before charging, add just enough distilled water to cover the plates. After charging is complete, add just enough distilled water to bring up the level to the indicator ring. If the water level is too high before charging, normal expansion rate of the electrolyte may cause an overflow. Resulting in a loss of battery acid balance and damage the machine.
5. Replace the battery caps, and leave them in place while charging.
6. Unplug the battery connector from the machine.

FOR SAFETY: When charging, connect the charger to the batteries before connecting the charger to the AC wall outlet. Never connect the charger to the AC wall outlet first. Hazardous sparks may result.

7. Plug the charger connector into the battery connector. Connect the charger AC plug to a wall outlet. The charger gauge should indicate that the batteries are charging.
8. When the batteries are fully charged, disconnect the charger from the AC wall outlet, then disconnect the charger from the batteries.
9. Connect the batteries to the machine connector.
10. Check the electrolyte level. It should be up to the indicator ring. If necessary, add distilled water.
11. Lower the solution tank.

CHANGING BATTERIES

Stop the machine in a clean area next to the charger. Turn off machine.

FOR SAFETY: Before leaving or servicing the machine; stop on level surface, turn off machine and remove key.

1. Raise the solution tank.
2. Engage solution tank support arm.
3. Disconnect battery pack from machine.
4. Use the proper size open end wrench to disconnect main ground wire first and secure cable terminal away from batteries.
5. Disconnect main positive lead and secure cable terminals away from batteries.
6. Loosen both terminals on each jumper cable and remove one at a time.
7. Prepare a suitable site to place the batteries.
8. Attach suitable battery lifting device and lift batteries from the machine.

⚠ WARNING

Batteries are a potential environmental hazard. Consult your battery supplier for safe disposal methods.

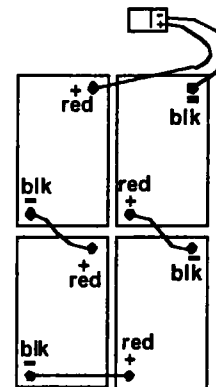

MAINTENANCE

SCRUB BRUSHES

NOTE: All original equipment brushes are equipped with "Perform Alert®". This feature will tell the operator when it is time to replace the scrub brushes. "Perform Alert®" brushes have pre-trimmed bright yellow tufts to indicate the length of a worn out brush. When the tufts in the scrub brush wear to a length equal to the yellow tufts, the scrub brushes should be replaced.

There are five different types of brushes available to cover applications from cleaning heavily soiled floors to polishing. A pad driver is also available to take advantage of the many cleaning pads on the market and further add to the flexibility of the BETCO. Please refer to the following to assist in selecting the proper brush or pad for the work at hand.

UNCOATED FLOORS

Aggressive Grit is a nylon fiber impregnated with silicone carbide grit. It grinds away stain, soil, and removes surface material.

Mild Grit is a less aggressive silicone carbide grit suitable for cleaning medium soil conditions. Advantages are faster ground speed than nylon bristles on light solid applications.

Nylon is a general-purpose scrub brush with stiff bristles. Polypropylene works well for maintaining concrete, wood and tile floors.

FINISHED FLOORS

Nylon Polish is the softest brush. It will gently clean finished tile or terrazzo floors without removing floor finish or floor material. Used for washing highly polished or burnished floors.

Nylon bristles are used in a variety of applications on coated or uncoated surfaces.

White Pads (Polishing) are used for dry polishing to achieve a high-gloss appearance, or surface washing on highly polished or burnished floors.

Red Pads (Buffing) are used for light-duty scrubbing. When used with a mild detergent they will provide surface cleaning without removing the finish.

Blue Pads (Scrubbing) are used for heavy-duty scrubbing and light stripping. The blue pads remove less finish than brown stripping pads, yet will remove black marks, stains and dirt.

Brown Pads (Stripping) are used for easy and complete removal of old floor waxes/finishes. They will quickly remove ground in dirt, black heel marks, and spills. When used with the proper stripper, this pad leaves the floor clean and ready for finishing.

The scrub brushes should be checked before each days work for wire, string, wear and damage. The scrub brushes should be replaced if brush bristles are missing or if yellow Perform Alert © indicates minimum brush length.

REPLACING OR INSTALLING SCRUB BRUSHES

1. With the scrub deck up, turn "OFF" the machine.

FOR SAFETY: Before leaving or servicing the machine; stop on level surface, turn OFF machine and remove key.

2. Locate release lever on top of brush or pad driver. Rotate release lever counter-clockwise and the brush/pad driver will release and drop down.
3. To reinstall, center the brush driver under the brush drive hub. Raise until it contacts brush driver assembly. Turn clockwise until release lever plate locks into position.

NOTE: Check that release plate is completely closed and pad/brush is securely attached. Damage to driver or brush could occur.

4. Repeat the procedure for the opposite side of machine.

SQUEEGEE BLADES

The front squeegee blade allows solution to pass through channels in the blade into the squeegee assembly while maintaining vacuum to provide lift. The front blade has four wear surfaces and can be rotated for extended life. There are three different notch patterns and three different colors of squeegees for varying floor conditions. The red blade has the most notches and is for normal, smooth surfaces. The blue blade has less notches and is for rougher or tiled surfaces. The green blade has no notches and is for rough surfaces such as knobby tile or uneven tile. The linatex blades are used for industrial settings. The front blade should not require regular replacement under normal use.

The rear blade wipes the floor to a near dry condition. It is important the rear blade be in good condition to properly do its job. As with the front blades there are 4 rear blade options; red, blue, green and linatex. Front and rear blades should be color matched. Each squeegee blade assembly has four wear surfaces for extended service.

Check both the front and rear squeegee blades for damage, wear, and adjustment each day in the pre-run check. Change the front blade if it is torn or has an uneven edge. Change the rear blade if it is less than 1/2 the original thickness.

ADJUSTING SQUEEGEE

Adjusting the squeegee is a two-part process. First, the squeegee assembly must have correct pitch in order for the squeegee blade to have the same deflection at each tip as well as the center. The knob on the squeegee linkage controls the pitch adjustment. The second adjustment is the deflection. Knobs on each end of the squeegee control the Standard Squeegee Assembly adjustment. A color-coded slide bar controls the Smart Squeegee Option adjustment according to the type of floor and squeegee blade employed.

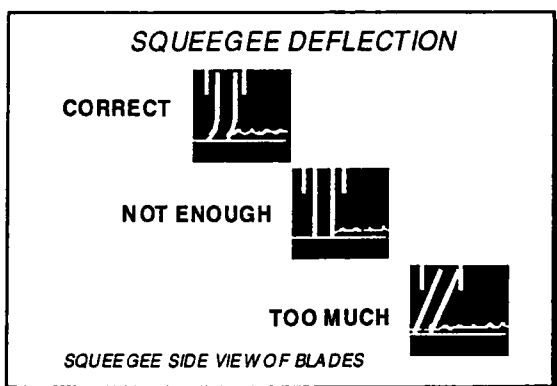

TO REMOVE SQUEEGEE ASSEMBLY

1. With the squeegee in the up position, turn key switch "OFF".
2. Disconnect vacuum hose from squeegee and loosen both knobs.
3. Pull squeegee assembly rearward from the lifting carrier.
4. Inspect or repair as necessary and reinstall.

TO REPLACE OR ROTATE REAR SQUEEGEE BLADES

1. With the squeegee in the up position, turn key switch "OFF".

FOR SAFETY: Before leaving or servicing machine; stop on level surface, turn off machine and remove key.

2. Remove the squeegee assembly from the machine. Unlatch and remove blade retainer strap and remove squeegee blade.
3. Rotate the squeegee to new edge position or replace as required. Each blade has four new edge positions.
4. Install blade on locating pins of squeegee assembly.
5. Install squeegee retainer strap.
6. For Smart Squeegee Option Only: Fasten and lock latch, adjust latch only tight enough to take up slack in retaining strap.

TO REPLACE OR ROTATE FRONT SQUEEGEE BLADE – STANDARD SQUEEGEE ASSEMBLY ONLY

1. With the squeegee in the up position, turn key switch "OFF".
2. Remove the squeegee from the machine. Loosen three thumbscrews and remove the retainer strap and squeegee blade.
3. Rotate the squeegee to new edge position or replace as required. Each blade has four new edge positions. When installing the front blade, tighten the center thumbscrew first. Insure that the retainer strap is pressed against the blade before tightening the outer screws.

MAINTENANCE

TO REPLACE OR ROTATE FRONT SQUEEGEE BLADE – SMART SQUEEGEE OPTION ONLY

1. With the squeegee in the up position, turn key switch "OFF".
2. Remove the squeegee from the machine. Release latch securing retainer strap.
3. Remove front retainer strap.
4. Remove squeegee blade from locating pins on squeegee assembly and rotate to new position or replace as required.
5. Install blade on locating pins of squeegee tool.
6. Replace front retainer strap.
7. Secure strap by locking latch.

TO ADJUST SQUEEGEE PITCH

1. Choose a smooth, level surface. Turn "ON" the key switch. Lower the squeegee and drive forward at least 2 feet (60cm.).
2. With the squeegee down, stop the machine. Do not allow machine to roll back.

FOR SAFETY: Before leaving or servicing the machine; stop on level surface, turn off machine and remove key.

3. Determine the differences, if any, in deflection of the squeegee blade between each end and the middle. Proper adjustment is obtained when deflection is equal all the way across the squeegee blade.
4. To decrease the deflection of the squeegee blade at the ends, loosen plastic knob near the squeegee center. To increase the deflection at the ends of the squeegee assembly, tighten plastic knob.
5. Check the deflection of the squeegee blades again. Repeat steps 1 through 4 until the deflection is equal across the entire rear squeegee blade.

TO ADJUST AMOUNT OF REAR SQUEEGEE DEFLECTION

1. Choose a smooth, level surface. Lower the squeegee and drive forward at least 2 feet.
2. With the squeegee down, stop the machine. Do not allow machine to roll back.

FOR SAFETY: Before leaving or servicing machine; stop on level surface, turn off machine and remove key.

3. Observe the amount of squeegee deflection. It should deflect 3/8 in. (9.5mm) across the entire width of the squeegee.
4. To increase the squeegee deflection, turn the 2 knobs at the squeegee ends CCW. To decrease the deflection, turn the knob CW.

NOTE: The deflection should be consistent along the length of the squeegee. If the deflection varies from end to end the knobs can be adjusted independently to correct the variation.

5. Turn on the key switch. Raise, then lower squeegee assembly. Drive forward at least 2 feet.
6. Repeat steps 2 through 4 until deflection of 3/8 in. (9.5mm) is reached.

SCRUB DECK SKIRT AND SQUEEGEE

The skirts and squeegee should be inspected for wear and damage. The skirt is self-adjusting. Replace skirt when they become cracked, worn, torn or brittle.

TIRES AND WHEELS

Check for low or worn tires. Fill to proper pressure as needed (50psi). Check wheel nuts for tightness, tighten as necessary.

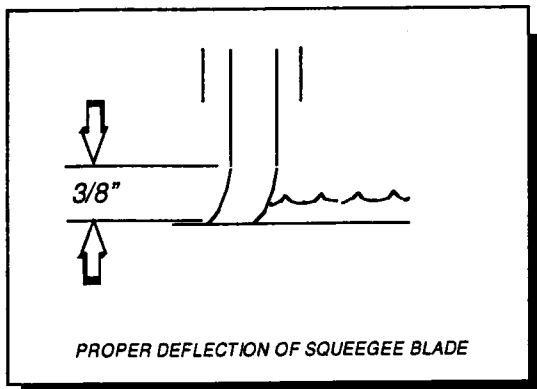

SERVICE SCHEDULE

**Before
starting
the work
period**

**End of
work
period
before
storing**

MAINTENANCE	DAILY	WEEKLY	MONTHLY	ANNUALLY
Check battery acid level	*			
Check vac hose connections	*			
Clean the squeegee blades	*			
Inspect brushes or pads for debris: wire string, wear	*			
Inspect vac fan shut off float screen	*			
Drain & rinse tanks	*			
Raise squeegee assembly	*			
Raise scrub deck assembly	*			
Charge the batteries.	*			
Remove the pad drivers/brushes	*			
Check the brushes/pads for damage and/or wear	*			
Clean squeegee blades.	*			
Clean recovery tank shut off & screen	*			
Check battery cells w/ hydrometer		*		
Check solution strainer		*		
Check pivot points, caster and squeegee for proper lubrication		*		
Inspect tank and hoses		*		
Clean tops of batteries and tray			*	
Check battery cable clamps			*	
Use a vacuum to remove lint from the motor windings			*	
Grease casters			*	
Inspect all motors for carbon motor brush wear				*

CONTROL HANDLE GROUP

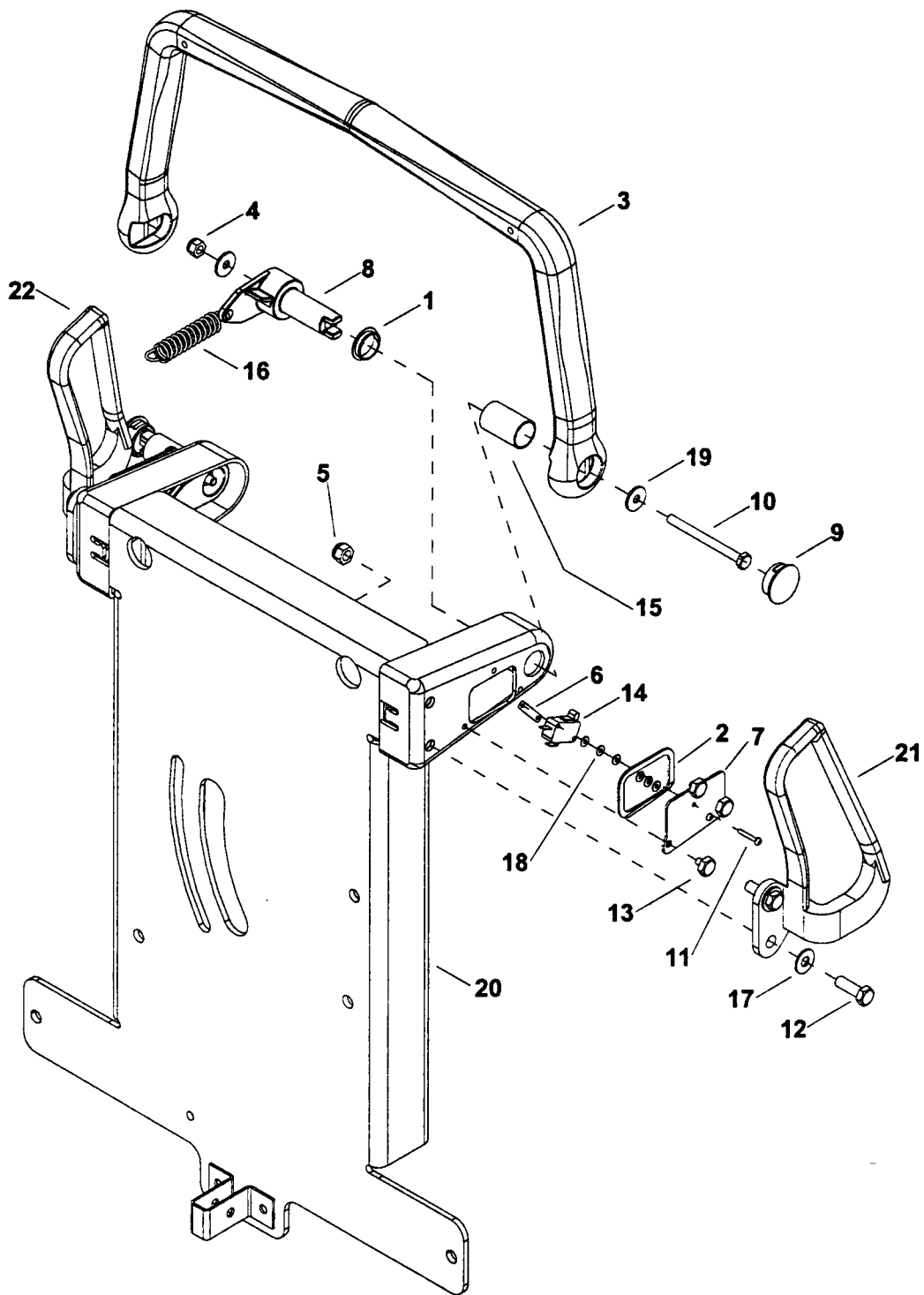

CONTROL HANDLE GROUP

ITEM	SKU	DESCRIPTION	QTY	SERIAL # FROM	NOTES
1	09129	BEARING, 3/4 NYLINER SI	2		
2	35220	GASKET, MICRO SWITCH COVER	2		
3	38275	HANDLE, CONTROL	1		
4	E85358	1/4"- 20 Nyloc Nut	2		
5	E81063	Nut, 5/16" - 18	4		
6	57247	NUT, PLATE SWITCH MOUNTING	2		
7	62726	PLATE, MICROSWITCH MOUNT	2		
8	66293	PIVOT, HANDLE	2		
9	66301	PLUG, 1.00 HOLE	2		
10	70129	SCR, 1/4-20 X 3.00 HHCS	2		
11	70245	SCR, 4-40 X 3/4 PPHMS	4		
12	70302	SCR, 5/16-18 X 1.00 HHCS GR5	4		
13	E87440	screw	6		
14	E87600	Switch, Micro	2		
15	73913	SPACER	2		
16	E87658	Spring	2		
17	E87623	Washer, 5/16" Flat SS	4		
18	87068	WASHER, 1/8 RIVET BACKUP	12		
19	87090	WASHER, 1/4 X 3/4 FLAT	4		
20	89186	WELDMENT, TOWER	1		
21	140247	BAR, GRAB HANDLE LEFT	1		
22	140248	BAR, GRAB HANDLE RIGHT	1		

CONTROL TOWER GROUP

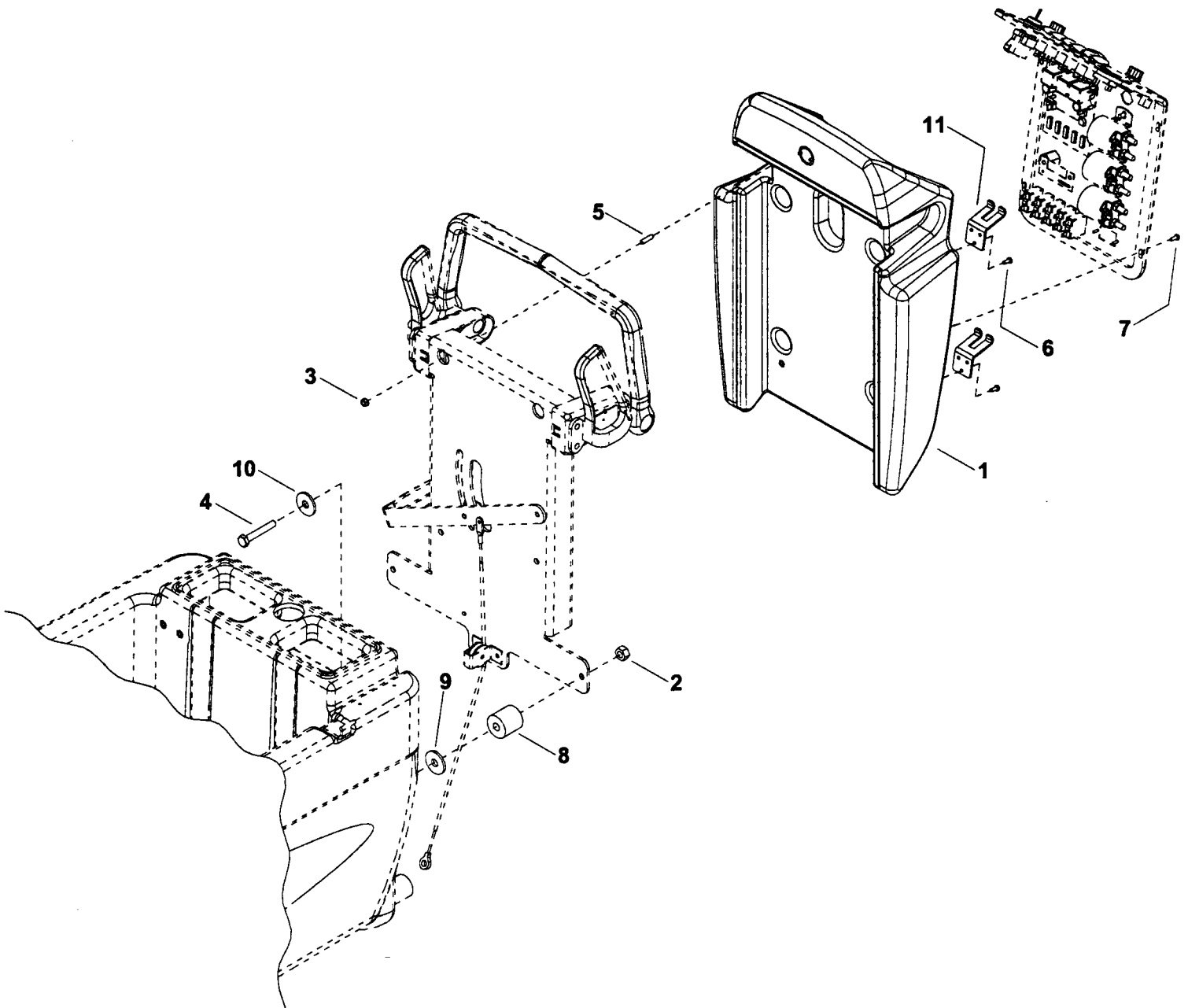

CONTROL TOWER GROUP

ITEM	SKU	DESCRIPTION	QTY	FROM	NOTES:
1	27874	CONSOLE, REAR	1		
2	E87636	NUT, 3/8-16 HEX NYLOCK	4		
3	57189	NUT 1/4-20 FLANGE LOCK	4		
4	E87547	SCR, 3/8-16 X 2 HHCS	4		
5	70393	SET SCR, 1/4-20X 1.25E	4		
6	70403	SCR #10 X 1/2 PHST TYPE B	6		
7	E88410	SCR 10-32 X 1/2 PPHMS BLK	6		
8	E87548	SPACER, 1.13D X.41 ID X.5THK	4		
9	87086	WASHER, M10 X 30 PLTD	2		
10	E87686	WASHER, 3/8 SEALING X 3/4 OD	4		
11	E87563	BRACKET, RECOVERY HOSE	2		

DECAL GROUP

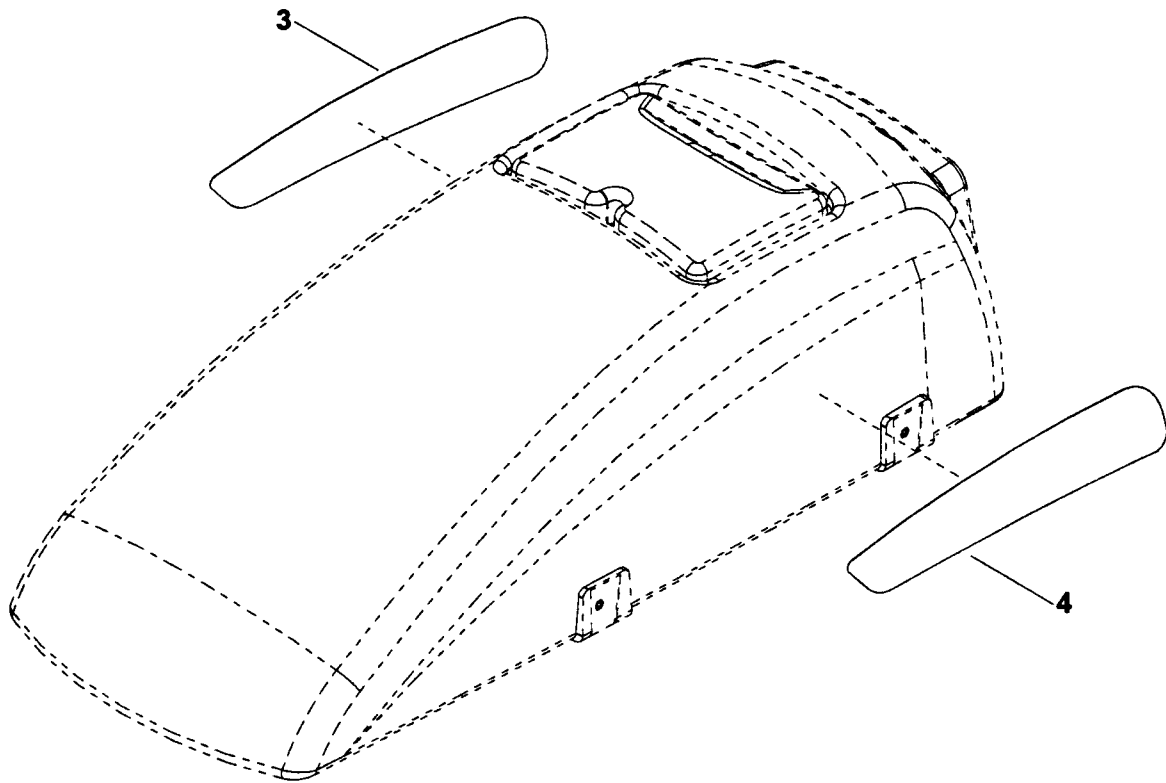
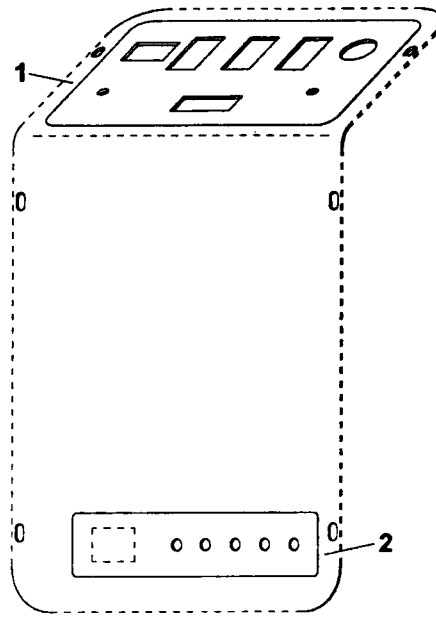

DECAL GROUP

ITEM	SKU	DESCRIPTION	QTY	NOTES:
1	500023	LABEL, SCRUBBER PANEL	1	
2	500024	LABEL CIRCUIT BREAKERS	1	
3	500161	LABEL, BETCO RIGHT	1	
4	500160	LABEL, BETCO LEFT	1	

ELECTRICAL PANEL GROUP

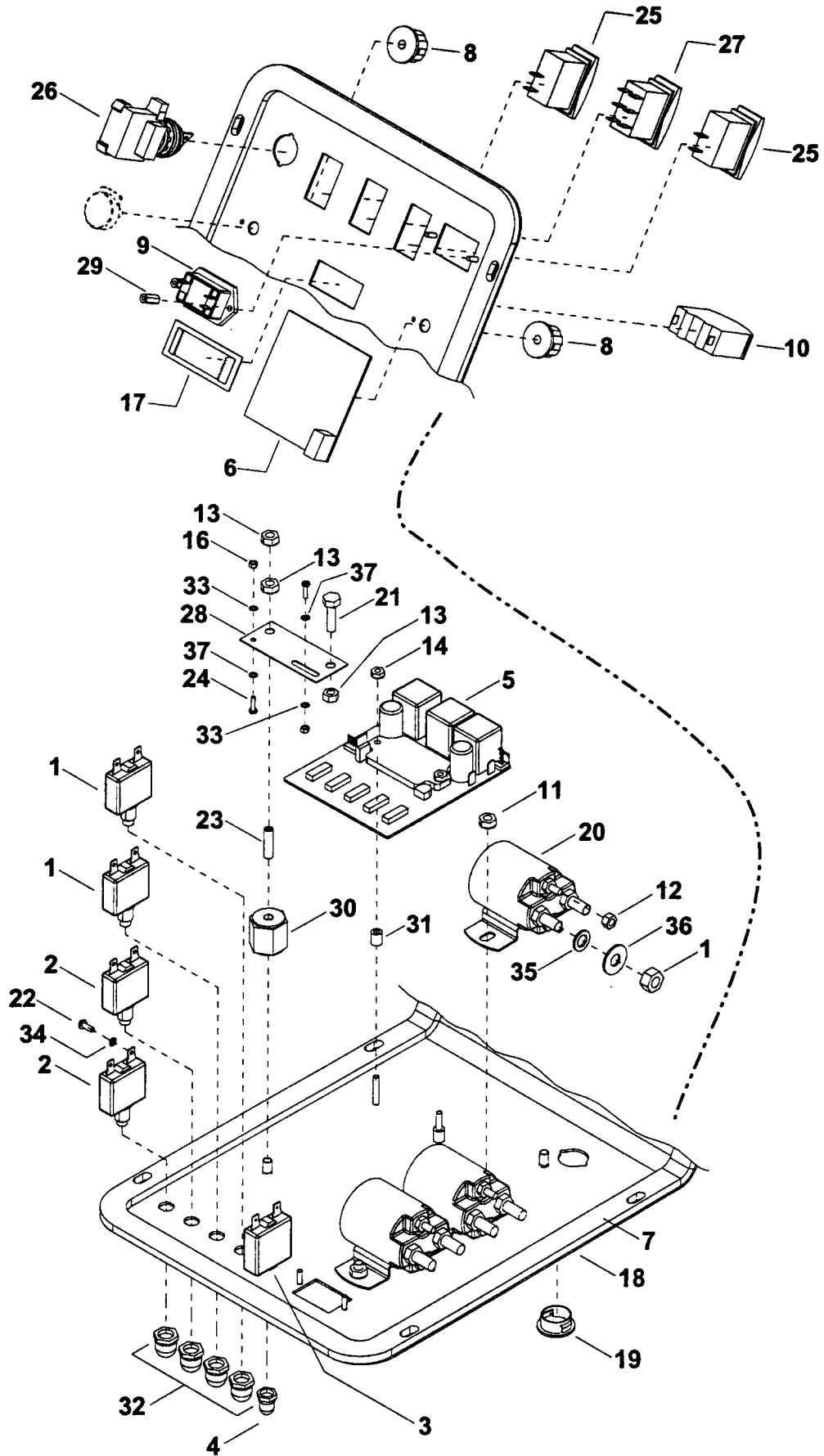

ELECTRICAL PANEL GROUP

ITEM	SKU	DESCRIPTION	QTY	NOTES
1	E87601	Breaker, 30A 250 VAC 50 VDC	2	
2	E87602	Breaker, 25A 250 VAC 50 VDC	2	
3	E87603	Breaker 3A 250 VAC 50 VDC	1	
4	E87505	Boot, 3-8 Circuit Breaker	1	
5	E87604	Controller, 24 VDC Propel Motor	1	
6	E87605	Circuit Board, Solution - Float	1	
7	35210	GASKET, ELECTRIC PANEL	1	
8	E87606	Knob 1.06 OD x .25 ID w/Setscrew	2	
9	E87607	Meter, 24V Battery Charge Level	1	
10	E87753	AMP Meter 0-50	1	
11	E85358	1/4"- 20 Nyloc Nut	4	
12	57104	NUT, 10-32	6	
13	E87221	Hex nut with star washer	3	
14	57106	NUT, 8-32 HEX W/STAR	2	
15	57117	NUT 5/16-24 HEX PLTD	6	
16	57256	NUT, 6-32 HEX BRASS	2	
17	E87472	Meter retaining plate WS28	1	
18	62808	PLATE, ELECTRIC PANEL	1	
19	66321	PLUG, .875 HOLE	1	
20	E87608	Relay, 24 VDC 100 Amp	3	
21	E87246	Screw 1/4-20 x 5/8 HHCS	1	
22	70067	SCR, 6-32 X 3/8 PPHMS SS	8	
23	70393	SET SCR, 1/4-20X 1.25L	1	
24	70615	SCR, 6-32 X 3/8 SRHMS BR	2	
25	E87609	Switch, SPST 2 Position Rocker	2	
26	E87610	Switch, Key 2 Position	1	
27	E87611	Switch DPDT 3-Position Rocker	1	
28	73987	SHUNT, DC AMM. 25 AMP, 50 MV	1	
29	73538	STANDOFF, 5/8 L, 6-32	2	
30	73659	STANDOFF, INS. 1.OL, 1/4-20	1	
31	73734	SPACER,	2	
32	E87458	Boot, seal push-button	4	
33	87026	WASHER, #6 LOCK EXT STAR SS	2	
34	87134	WASHER, #6 SPLIT	8	
35	E87580	flat washer FS28/32	6	
36	87166	WASHER, 5/16 EXT LOCK PLTD	6	
37	87187	WASHER, #6 FLAT BRASS	2	

FRONT COVER GROUP

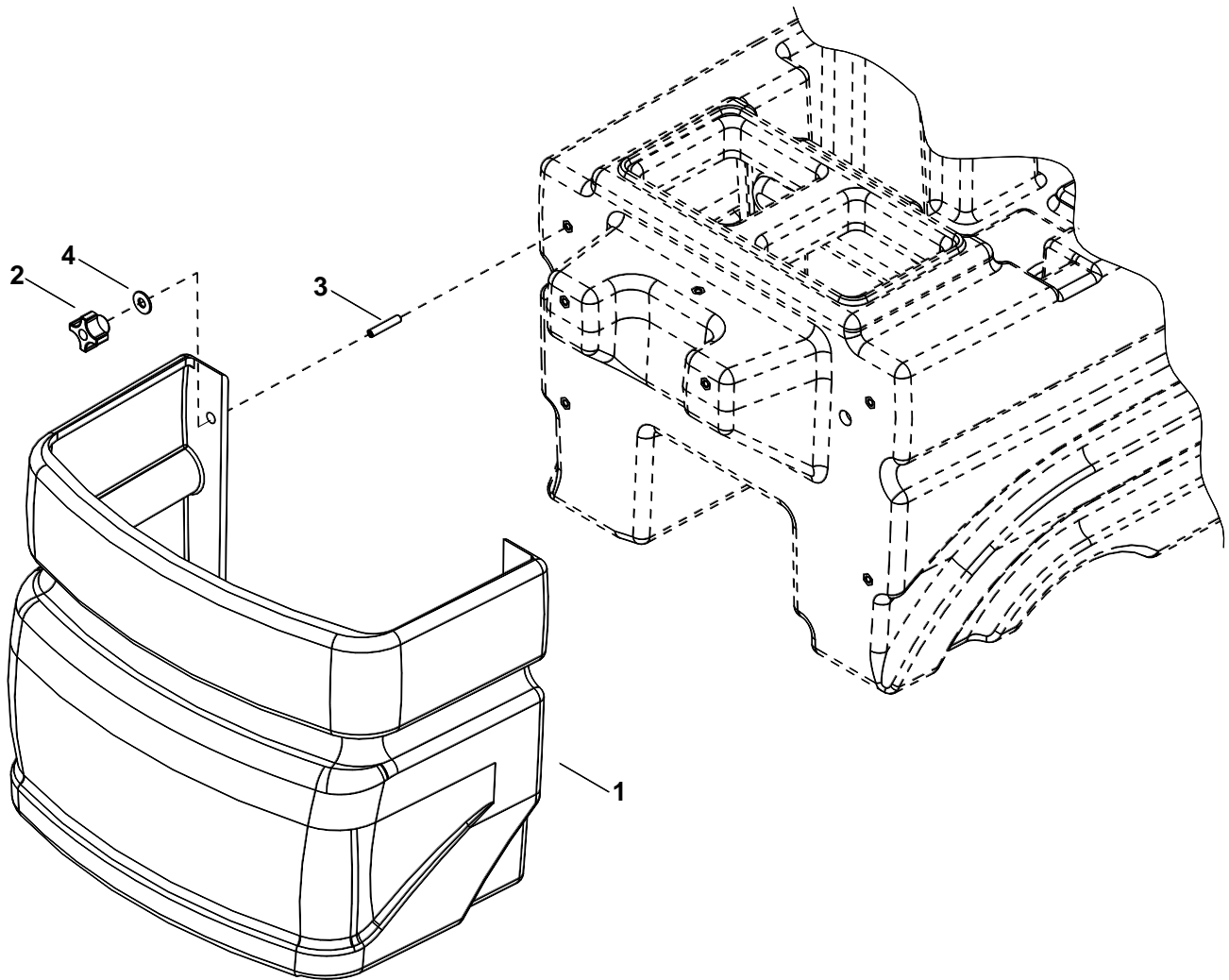

FRONT COVER GROUP

REF	PART NO.	QTY	DESCRIPTION	SERIAL NO. FROM	NOTES:
1	E87557	1	COVER, FRONT DK GRY		
2	E87664	2	KNOB, 5/16-18 4 PRONG		
3	70639	4	SCR, 5/16 X 1.75 SSSCU		
4	E87623	2	WASHER, 5/16 FLAT SS		

RECOVERY TANK GROUP

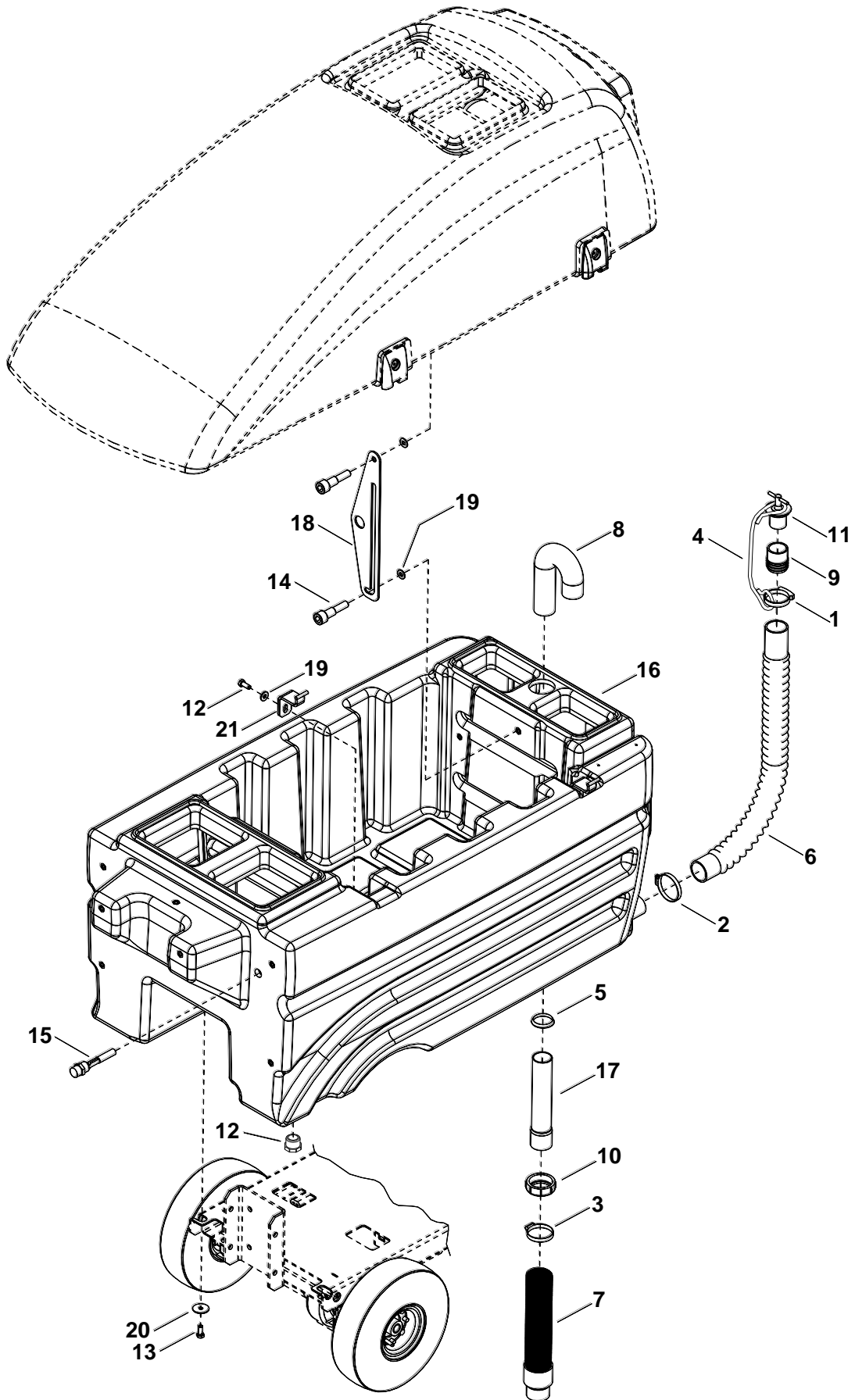

RECOVERY TANK GROUP

REF	PART NO.	QTY	DESCRIPTION	SERIAL NO. FROM	NOTES:
1	E85358	1	CLAMP, 2" NYLON RACHET		
2	E87613	1	CLAMP, 2.5" WORM GEAR		
3	E85458	1	CLAMP, 2.0" WORM GEAR X .312W		
4	E87615	1	CORD, DRAIN PLUG		
5	E87489	1	GASKET, 1 1/2 COMPRESSION		
6	E87616	1	HOSE, 1.5 X 24.0 DRAIN		
7	E87617	1	HOSE ASM, 1.5 X 11 BLK VAC		
8	E87618	1	HOSE, P-TRAP		
9	E87619	1	HOSEBARB, 1.5 DOUBLE MCHD		
10	E87490	1	NUT, 1.5 SLIP JOINT		
11	E87620	1	PLUG, DRAIN HOSE		
12	66240	1	PLUG, 3/4" MPT PVC		
13	E87730	6	SCR, 5/16-18 X 3/4HHCSGR5PLTDL		
14	E87690	2	SHOULDER BOLT, 3/8OD X 3/8L SS		
15	E87621	1	SWITCH ASM, FLOAT		
16	75311	1	TANK, RECOVERY DK GRY		
17	E87498	1	TUBE, 1.50 X 12.0" PVC		
18	82575	1	PLATE, TANK SUPPORT		
19	E87623	4	WASHER, 5/16 FLAT SS		
20	87102	4	WASHER, 5/16 ID X 1-1/4 OD		
21	E87323	2	WLDMNT, HINGE PIN		

SCRUB BRUSH/PAD DRIVER GROUP – 28 IN

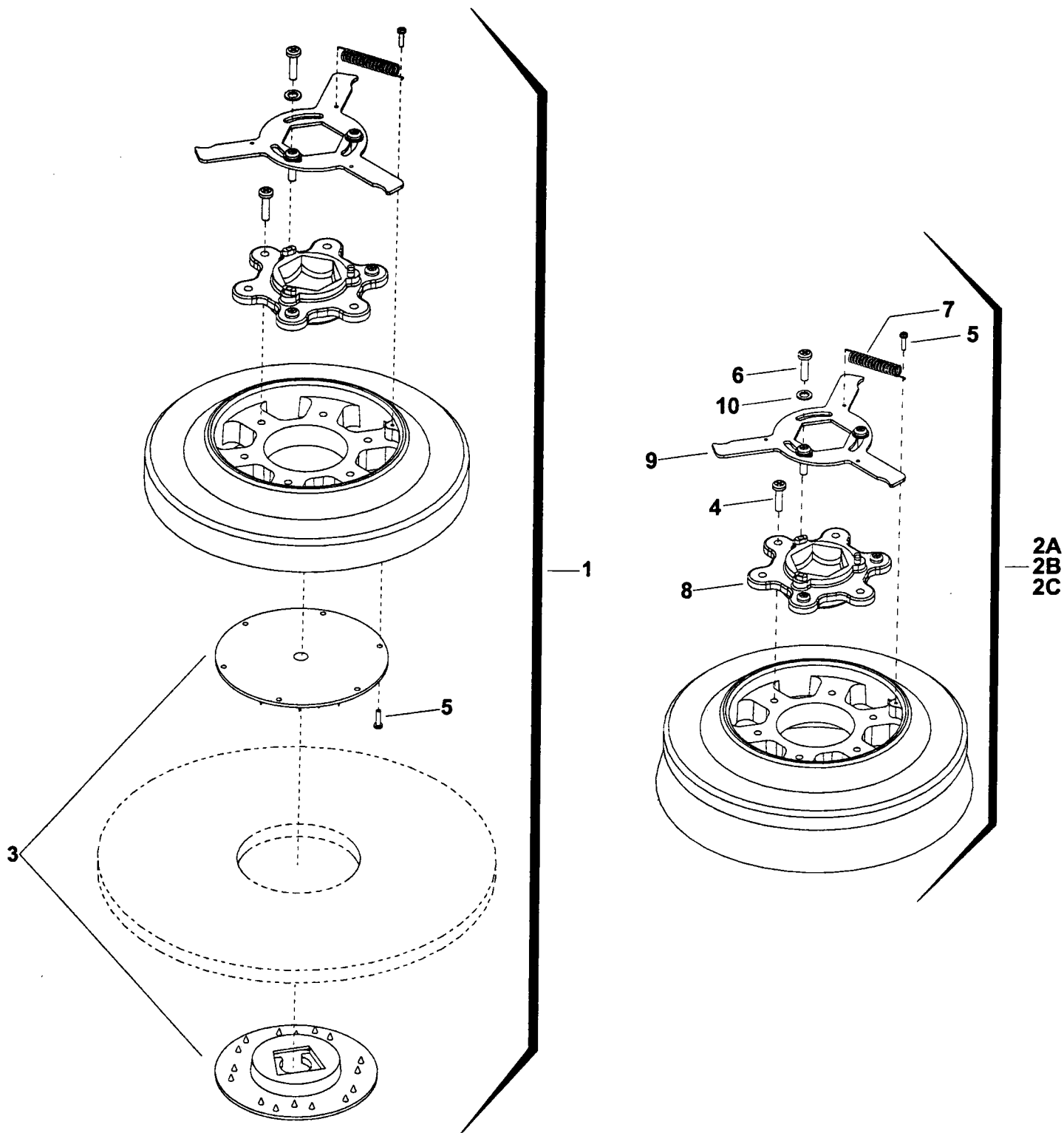

SCRUB BRUSH/PAD DRIVER GROUP – 28 IN

REF	PART NO.	QTY	DESCRIPTION	SERIAL NO. FROM	NOTES:
1	2337	-	PAD DRIVER, 14" HEX		
2A	2344	-	BRUSH, 14" POLYPROPYLENE HEX		
2B	2345	-	BRUSH, 14" NYLON HEX		
2C	2346	-	BRUSH, 14" MILD GRIT HEX		
3	E85090	-	LOCK, PAD CENTER SNAP, TWO STEP		
4	E87558	-	SCR, 1/4-20 X 5/8 PPHTC SS		
5	E87499	-	SCR, #8 X 1/2 PPH T/S SS		
6	E87558	-	SCR, 1/4-20 X 5/8 PPHTC SS		
7	E87313	-	SPRING, EXT .31D X 2.0L X .03W		
8	E87331	-	CLUTCH, HEX DRIVE		
9	81471	-	PLATE, BRUSH RELEASE		
10	E87414	-	WASHER, 1/4 ID X 5/8 OD SS		

SCRUB BRUSH/PAD DRIVER GROUP (STAR DRIVE)-28 IN

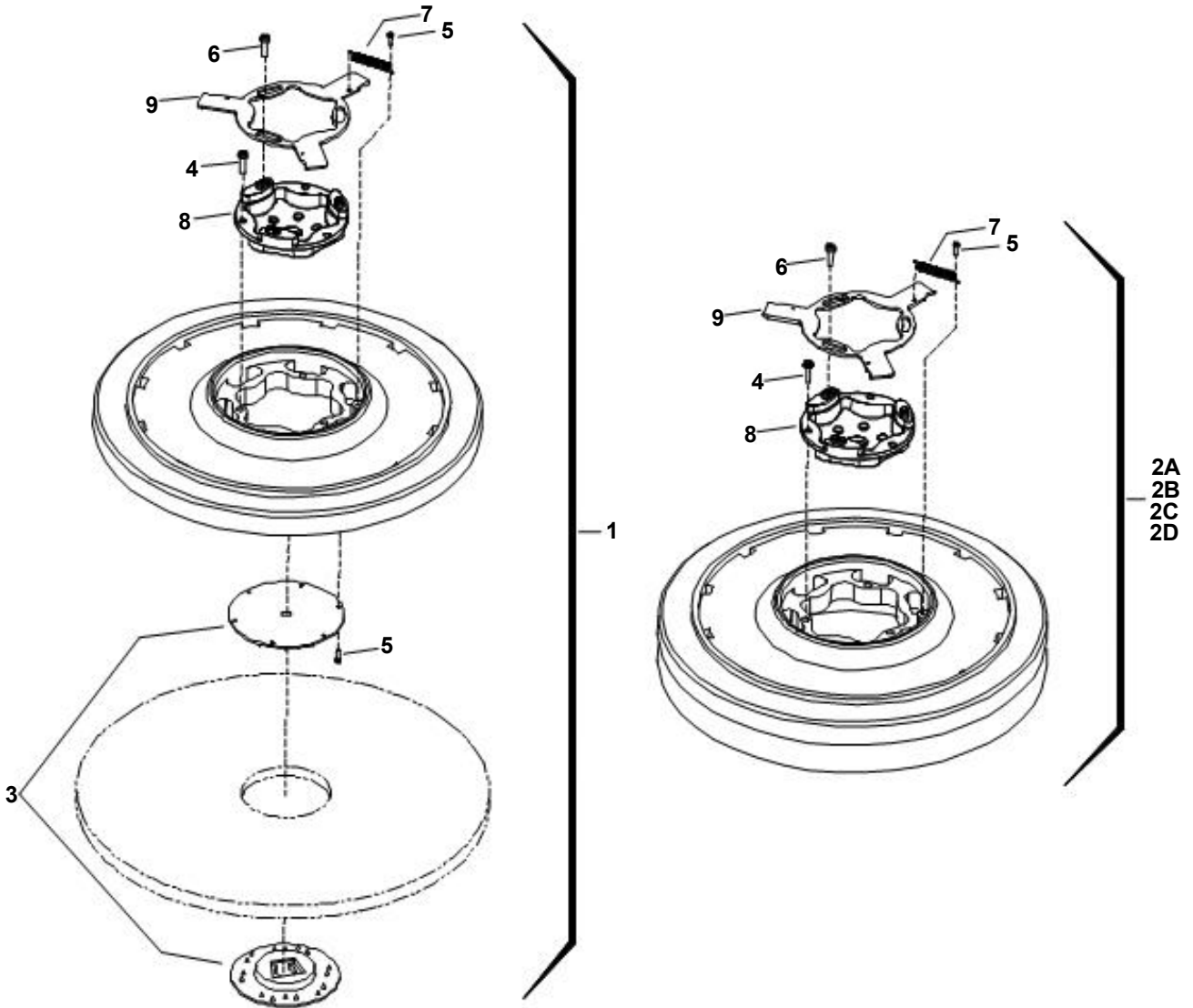

REF	PART NO.	QTY	DESCRIPTION
1	2412	2	PAD DRIVER, 14" SD
2A	2413	2	BRUSH, 14" POLYPROPYLENE SD
2B	2414	2	BRUSH, 14" NYLON SD
2C	2416	2	BRUSH, 14" MILD GRIT SD
2D	2417	2	BRUSH, 14" SUPER AGG SD
3	E85090	1	LOCK, PAD CENTER SNAP, TWO STEP
4	70695	3	SCR, 12-24 X 1.0 PPHMS SS
5	70694	4	SCR, 8-32 X 3/4 PTHMS
6	70696	3	SCR, 10-32 X 3/4 PTHMS
7	E87313	1	SPRING, EXT .31 D X 2.0 L X .03 W SS
8	E87691	1	SOCKET, DRIVE BRUSH
9	E87692	1	PLATE, BRUSH RELEASE

SCRUBHEAD GROUP - 28 IN

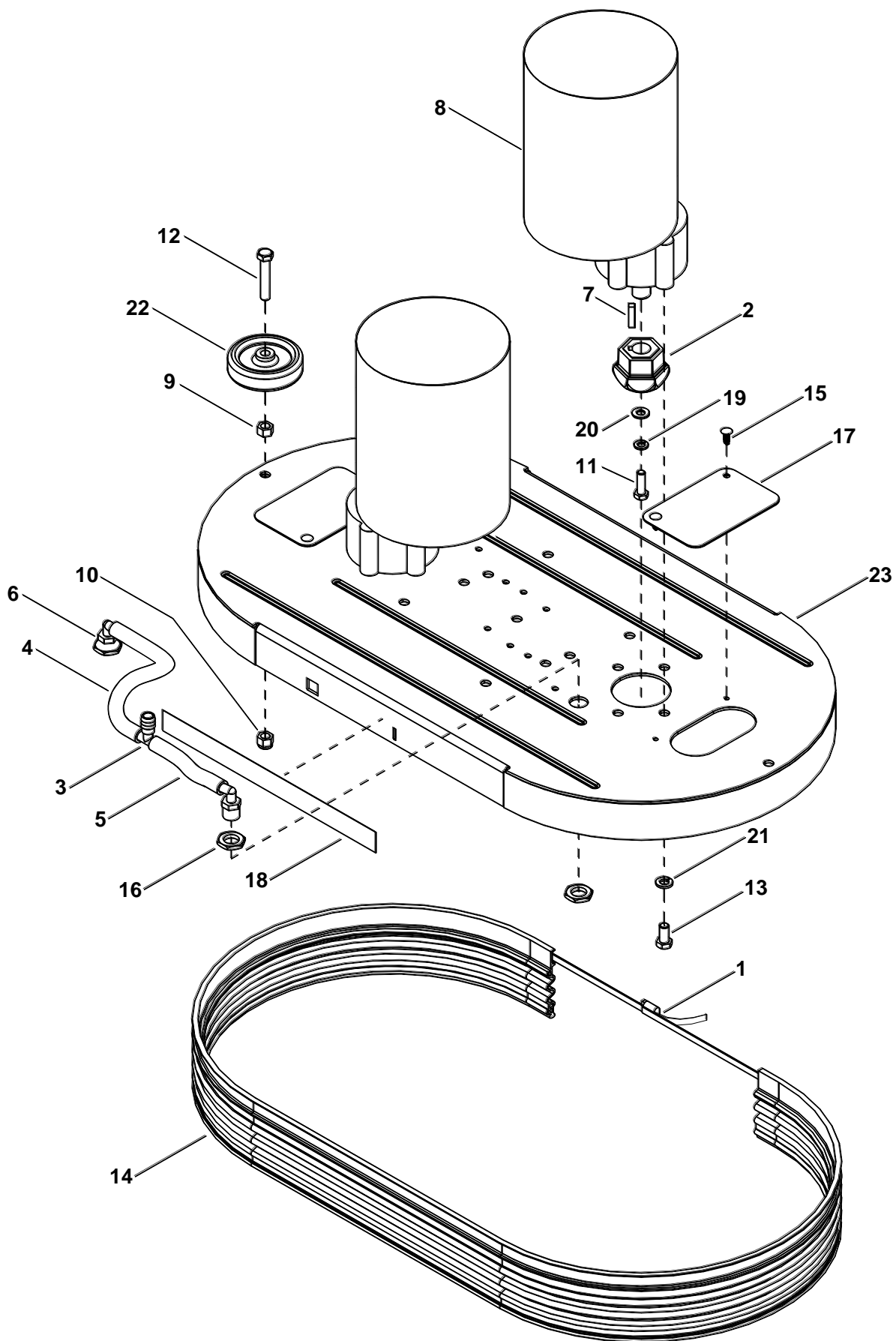

SCRUBHEAD GROUP – 28 IN

REF	PART NO.	QTY	DESCRIPTION	SERIAL NO. FROM	NOTES:
1	E87642	1	CLAMP, WORM GEAR .5WX24 #390		
2	E87659	2	DRIVER, BRUSH		
3	E87556	1	FITTING, 1/2 X 3/8 X 3/8 RED. TEE		
4	39053	1	HOSE, 3/8 NYLOBRAID X 7.0"		
5	E87555	1	HOSE, 3/8 NYLOBRAID X 5-1/2"		
6	E87688	2	HOSEBARB, 3/8 MPT X 3/8 HOSE 90		
7	E87530	2	KEY, 1/4 SQ X 1.00		
8	E87731	2	MOTOR ASM, 24VDC 200 RPM GEAR		
	14695	-	BRUSH SET, BRUSH MOTOR IMPRL		(NOT SHOWN)
	140394	-	BRUSH SET,53185/630/632 ASI		(NOT SHOWN)
9	E87643	1	NUT, 3/8-16 HEX		
10	E87636	1	NUT, 3/8-16 HEX NYLOCK		
11	E87709	2	SCR, 5/16-18 X 1.00 HHCS SS		
12	E87644	1	SCR, 3/8-16 X 2.00 HHCS GR5		
13	E81080	8	SCR, 3/8-16 X 3/4 HHCS GR5		
14	E87320	1	SKIRT, SHROUD 3.25 X 65.0 L		
15	E87698	4	CLIP, TREE .19 HOLE FLAT HEAD		
16	E87746	4	NUT, SEALED BULKHEAD		
17	E87699	2	COVER, BRUSH RELEASE		
18	82923	1	PAD, ANTI SLIP 1.00 X 12.0 L		
19	87083	2	WASHER, 5/16 SPLIT		
20	E87580	2	WASHER, .34 X .69 FLAT		
21	87163	8	WASHER, 3/8 SPLIT		
22	E87652	1	WHEEL, SQUEEGEE		
23	E87256	1	WELDMENT, SCRUB HEAD 28IN		

SCRUBHEAD LIFT GROUP-DISK

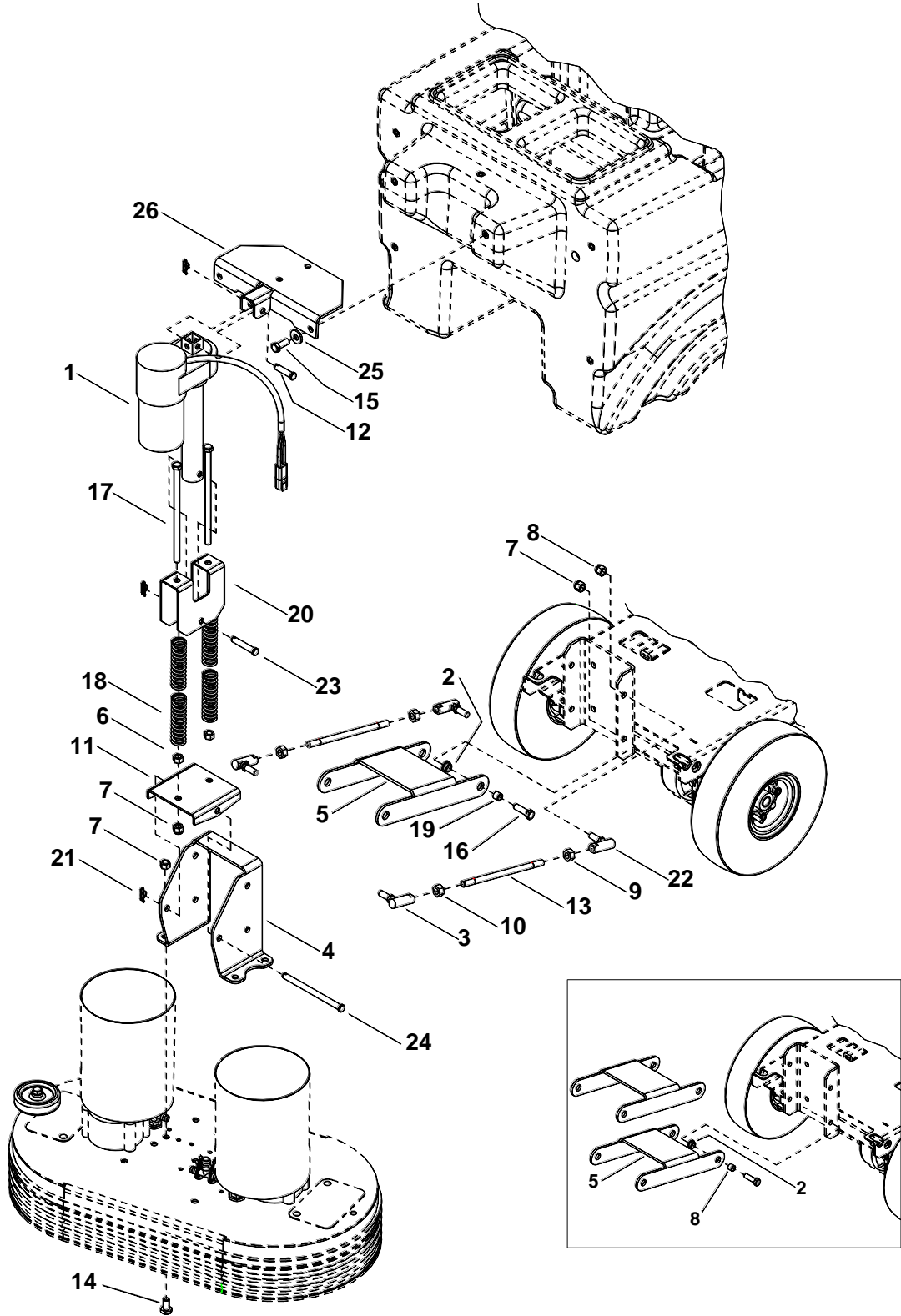

SCRUBHEAD LIFT GROUP-DISK

REF	PART NO.	QTY	DESCRIPTION	SERIAL NO. FROM	NOTES:
1	E87622	1	ACTUATOR, 24 VDC 5.0 STROKE		
2	09130	8	BEARING, 1/2 NYLINER SF		
3	140353	2	BALL JOINT ASSY, 3/8-24 LH	*	
4	140372	1	BRKT, SCRUB HEAD MOUNT		
5	27856	1	LINKAGE, SCRUB DECK	*	WAS QUANTITY 2
6	E87643	2	NUT, 3/8-16 HEX		
7	E87636	10	NUT, 3/8-16 HEX NYLOCK		
8	57216	4	NUT, 3/8-24 HEX NYLOCK	*	
9	57217	2	NUT, 3/8-24 HEX JAM PLTD	*	
10	57263	2	NUT, 3/8-24 UNF LH	*	
11	62676	1	PLATE, SPRING SUPPORT		
12	66232	1	PIN, CLEVIS 3/8 X 1.50		
13	E88021	2	ROD, SCRUB LIFT	*	
14	E87637	4	SCR, 3/8-16 X 1" HHCSGR5PLT DL		
15	E87730	3	SCR, 5/16-18 X 3/4HHCSGR5PLTDL		
16	E87685	8	SCR, 3/8-16 X 1.25 HHCS GR5		
17	70574	2	SCR, 3/8-16 X 7.5 HHCS GR5 PLTD		
18	81311	4	SPRING, COMP. 1.00 X 3.5L X .135W		
19	80102	8	SPACER, .500 OD X .391 ID X .400		
20	80459	1	PLATE, SPRING RETAINER		
21	E87481	3	COTTER, 3/8" RING		
22	80697	2	BALL JOINT ASY, 3/8-24 RH	*	
23	81406	1	PIN, CLEVIS 3/8" X 2"		
24	E87482	1	PIN, CLEVIS 3/8 X 5.25		
25	E87623	3	WASHER, 5/16 FLAT SS		
26	89204	1	WELDMENT, ACTUATOR BRKT		

SOLUTION TANK GROUP

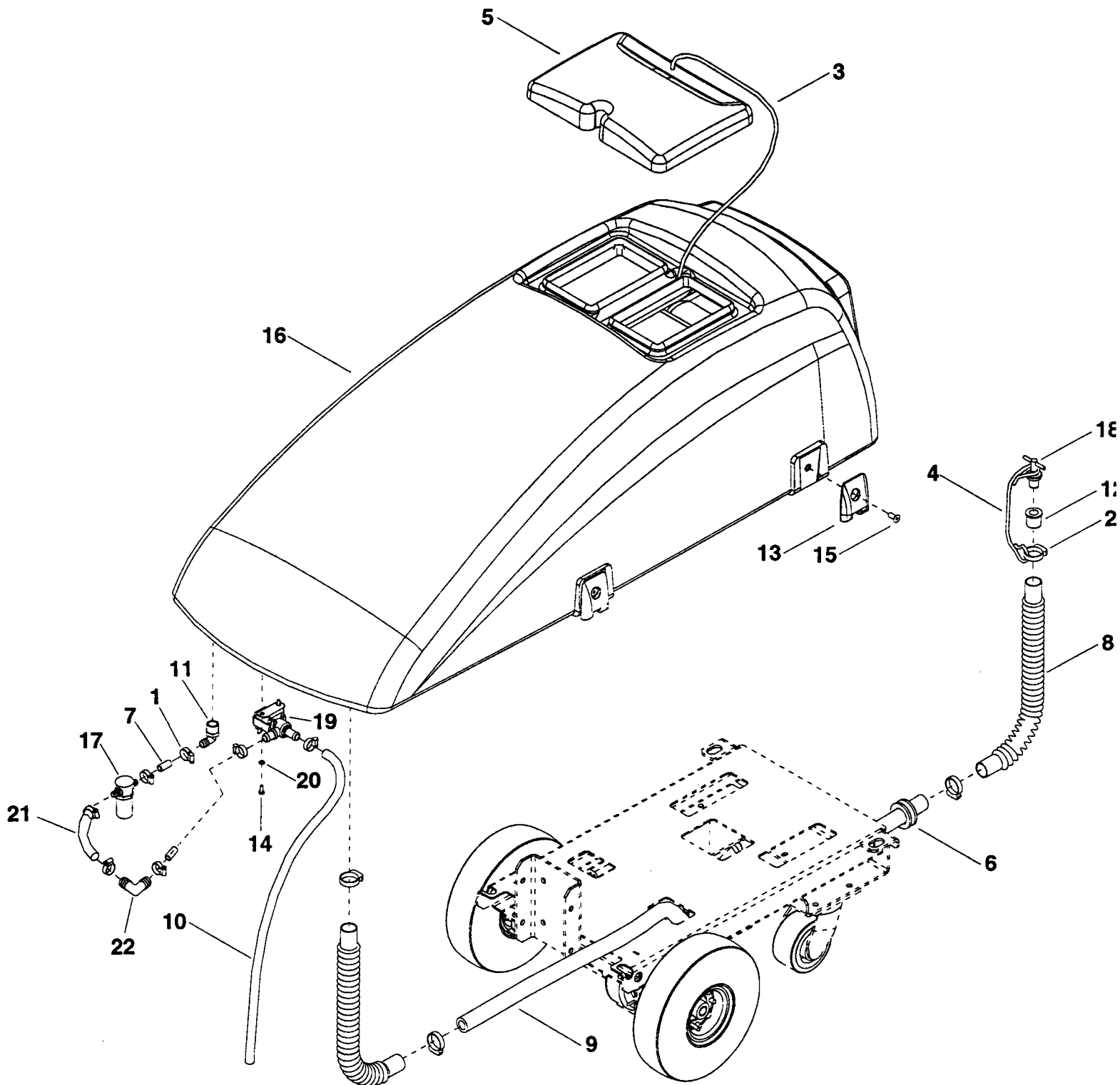

SOLUTION TANK GROUP

REF	PART NO.	QTY	DESCRIPTION
1	20042	6	CLAMP, 3/8 HOSE (D-SLOT)
2	E87743	4	CLAMP, 1.0 NYLON RACHET
3	27425	1	CORD, SOLUTION COVER
4	E87615	1	CORD, DRAIN PLUG
5	E87624	1	COVER, SOLUTION TANK
6	36191	1	GROMMET 1.00 ID 3/16 GRIP
7	39498	2	HOSE, 1/2" NYLOBRAID X 1 1/2"
8	E87625	2	HOSE, 1.0 X 18.0 DRAIN
9	E87626	1	HOSE, 3/4 ID X.12W X 32" CLR
10	E87255	1	HOSE, 1/2 NYLOBRAID X 36"
11	E87497	1	HOSEBARB, 1/2MPT X 1/2 HOSE 90
12	E87627	1	SLEEVE.63 ID X 1.0 OD
13	E87322	2	HINGE, SCRUBBER TANK
14	E87559	2	SCR, 10-32 X 1/2 PPHMS SS
15	E87717	2	SCR, 5/16-18 X 3/4 FHSCS BLKZC
16	E87716	1	TANK, SOLUTION
17	E87628	1	STRAINER, 1/2 HOSE 40 MESH
18	E87629	1	PLUG, 5/8" DRAIN HOSE
19	E87630	1	VALVE, 24VDC SOL.1/2"HOSEBARB
20	87095	2	WASHER, #10 FLAT PLTD
21	39549	1	HOSE, 1/2" WIRE BOUND X 5"
22	40082	1	HOSEBARB, 1/2 X 90D

SQUEEGEE GROUP - 28 IN SCRUBHEAD

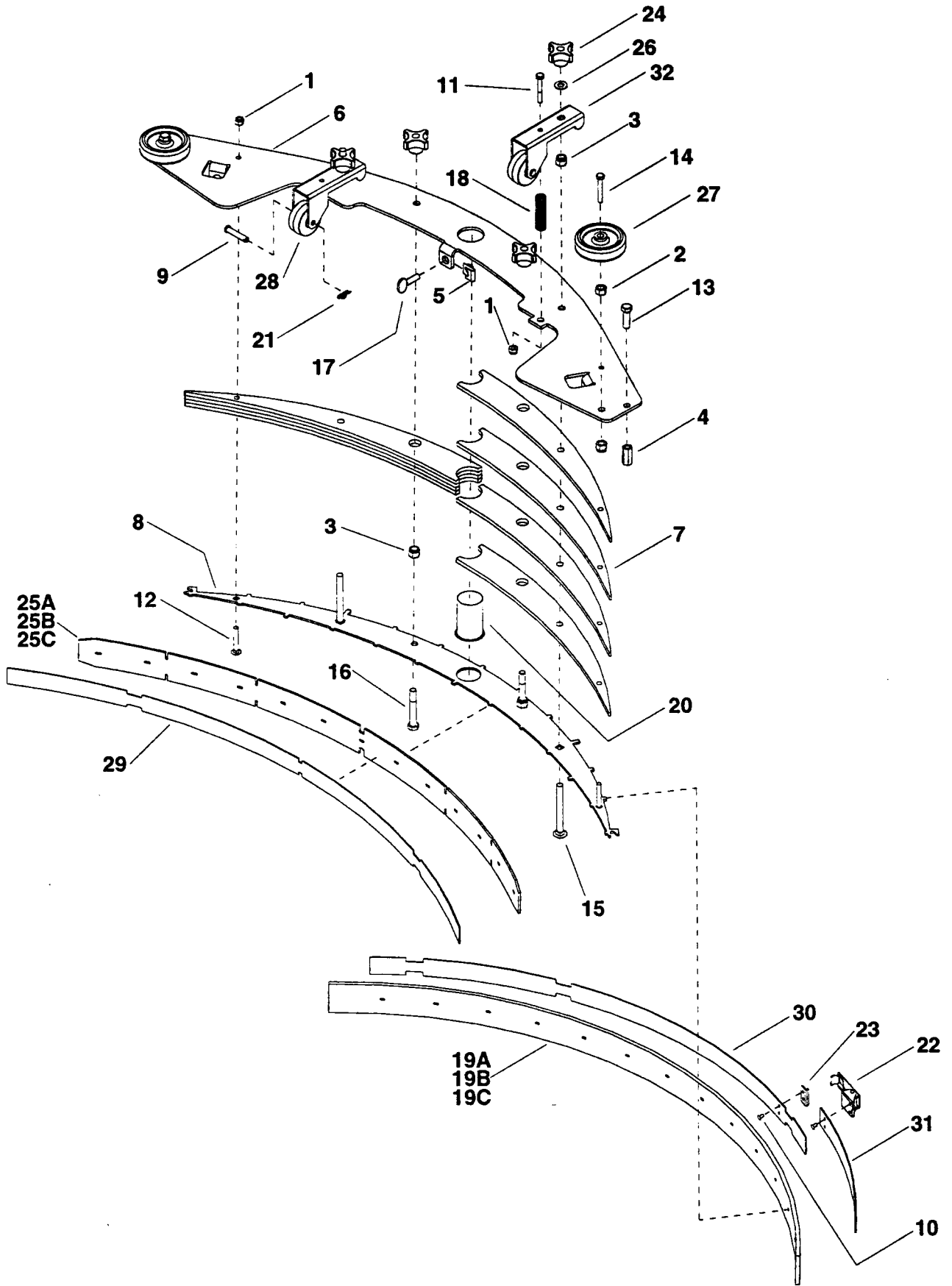

SQUEEGEE GROUP - 28 IN SCRUBHEAD

REF	PART NO	QTY	DESCRIPTION
1	E85358	4	NUT, 1/4-20 HEX NYLOCK
2	E87643	2	NUT, 3/8-16 HEX
3	E87636	6	NUT, 3/8-16 HEX NYLOCK
4	57269	2	NUT, 3/8-16 HEX COUPLING SS
5	E87234	3	NUT, 5/16-18 CAPTIVE "J" PLTD
6	E87525	1	PLATE, SQG RETAINER TOP
7	62812	8	PLATE, SQUEEGEE FILLER
8	E87524	7	PLATE, SQG BLADE RETAINER
9	E87531	2	PIN, CLEVIS 5/16 X 1.625 LG
10	E87675	4	RIVET, 5/32 OF X 1/8 GRIP
11	E87233	2	SCR, 1/4-20 X 1.75 HHCS PLTD
12	E87463	2	SCR, 1/4-20 X 1.5 ELEVATOR
13	E87685	2	SCR, 3/8-16 X 1.25 HHCS GR5PLT
14	E87644	2	SCR, 3/8-16 X 2.0 HHCS GR5 PLT
15	E87462	2	SCR, 3/8-16X3.5 CARRIAGE PLTD
16	E87390	2	SCR, 3/8-16 X 2.5 TAP
17	E87465	3	SCR, 5/16-18X1 THUMB SS TYPE P
18	E87646	2	SPRING, COMP.60D X2.0L X.045W
19A	E87647	1	SAGE BLADE, REAR LINATEX 44"
19B	E87713	-	SAGE BLADE, REAR (TILE) 44"
19C	73901	-	SAGE BLADE, REAR (BUTTONS) 44"
20	E87450	1	TUBE, 1.5 OD X 2.5 VAC INTAKE
21	E87598	2	COTTER, 5/16" RING
22	E87648	1	LATCH, SQUEEGEE STRAP
23	E87649	1	STRIKER, SQUEEGEE STRAP REAR
24	E87650	4	KNOB, 3/8-16 4 PRONG
25A	E87651	1	SQUEEGEE, FRONT BLADE LINATEX
25B	E87676	-	SQUEEGEE, FRONT BLADE (TILE)
25C	82640	-	SQUEEGEE, FRONT BLADE (BUTTON)
26	E87445	2	WASHER, 3/8 ID X 3/4 OD NYLON
27	E87652	2	WHEEL, BUMPER
28	E87653	2	WHEEL, 2 OD X.31IDX.875W, GRY
29	E87654	1	BAND, SQUEEGEE FRONT
30	E87655	1	BAND, SQUEEGEE REAR
31	E87656	1	BAND, SQUEEGEE REAR (S)
32	E87660	2	BRKT, WHEEL MOUNT

SQUEEGEE LIFT GROUP

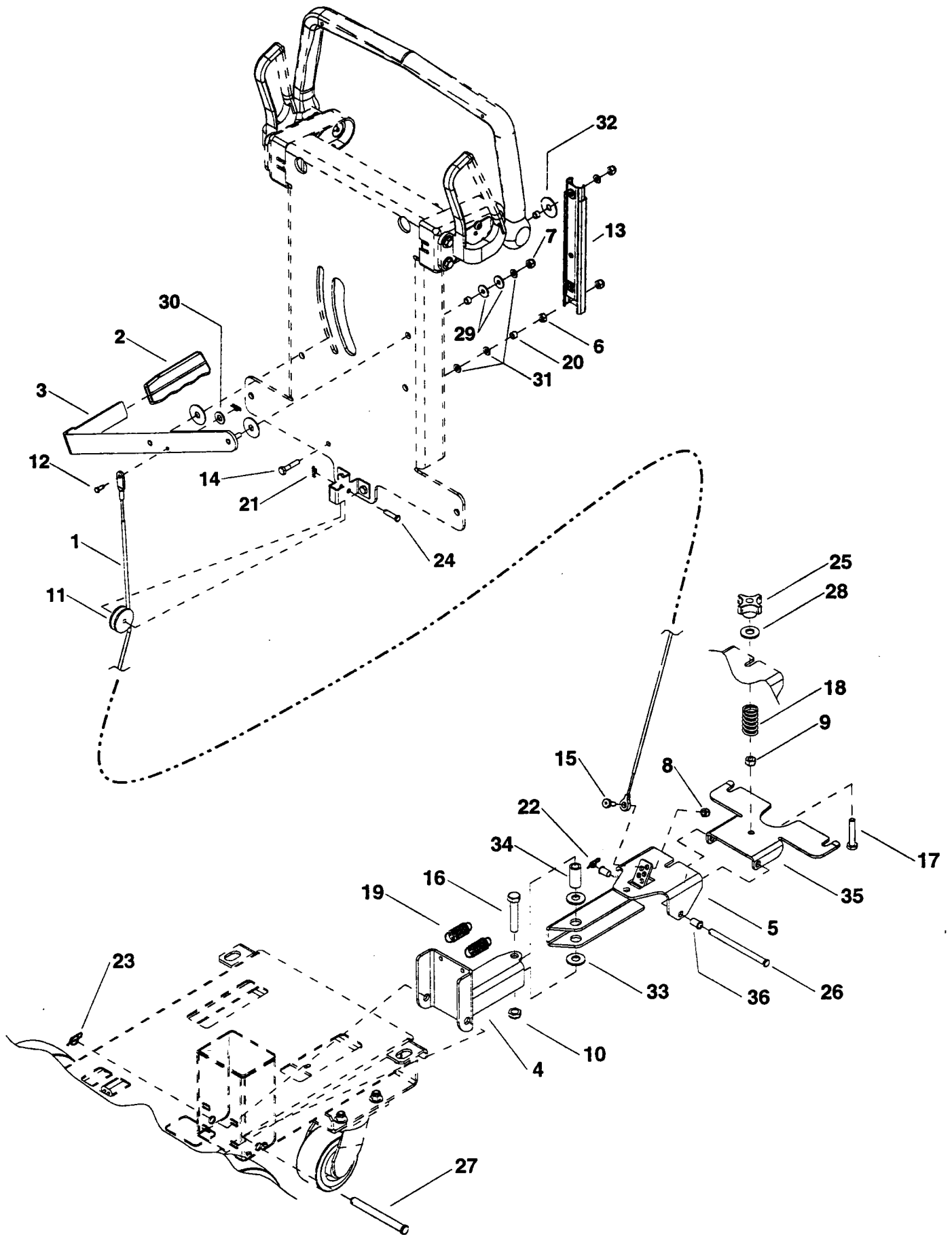

SQUEEGEE LIFT GROUP

REF	PART #	QTY	DESCRIPTION
1	E87631	1	CABLE, 23.70 X 1/8
2	E87162	1	GRIP, 3/16 X 1.0 FLAT BAR
3	E87376	1	LEVER, SQUEEGEE LIFT
4	51322	1	LINKAGE, SQUEEGEE LIFT
5	51323	1	LINKAGE, SQUEEGEE PIVOT
6	E87441	1	NUT, 1/4-20 HEX
7	E85358	3	NUT, 1/4-20 HEX NYLOCK
8	E81063	1	NUT, 5/16-18 HEX NYLOCK
9	E87636	1	NUT, 3/8-16 HEX NYLOCK
10	57153	1	NUT, 1/2-13 X HEX NYLOCK THIN
11	E87263	1	PULLEY, 1.5 ODX.5WX.25B
12	E87425	1	PIN, CLEVIS 3/16" X 1/2" PLTD
13	E87729	1	RAIL RACHET
14	70297	1	SCR, 1/4-20 X 1.5 HHMS
15	E87690	1	SHOULDER BOLT, 3/8OD X 3/8L SS
16	70341	1	SCR, 1/2-13 X 2.5 HHCS GR5PLT
17	E87242	1	SCR, 3/8-16 X2.75 HHTB GR5 PLTD
18	E87466	1	SPRING, COMP 1.100DX2.OLX.148W
19	E87241	2	SPRING, EXT. 1.00 OD X 4.0 L
20	E87446	3	TUBE, .38 OD X.26 ID X.38 LG
21	E87436	2	COTTER, 1/4 RING
22	E87481	1	COTTER, 3/8 RING
23	80607	1	COTTER, 1/2 RING
24	80612	1	PIN, CLEVIS 1/4 X 1.0
25	E87588	1	KNOB, 3.50 ODX3/8-16 THRU HOLE
26	E87482	1	PIN, CLEVIS 3/8 X 5.25
27	82322	1	PIN, CLEVIS 1/2 X 4.80
28	87086	1	WASHER, M10 X 30 PLTD
29	E87445	2	WASHER, 3/8 ID X 3/4 OD NYLON
30	E87444	1	WASHER, M6 FLAT
31	E87447	4	WASHER, .26 ID X.50 OD
32	E87448	3	WASHER, .4 ID X 1.3 OD NYLON
33	87201	2	WASHER, 0.781 ID FIBERGLIDE
34	140293	1	SPACER, .75 OD X.50 ID X 1.50 L
35	E87334	1	BRACKET, SQUEEGEE MOUNT
36	E87480	2	BEARING, FLANGED PLASTIC

VACUUM GROUP

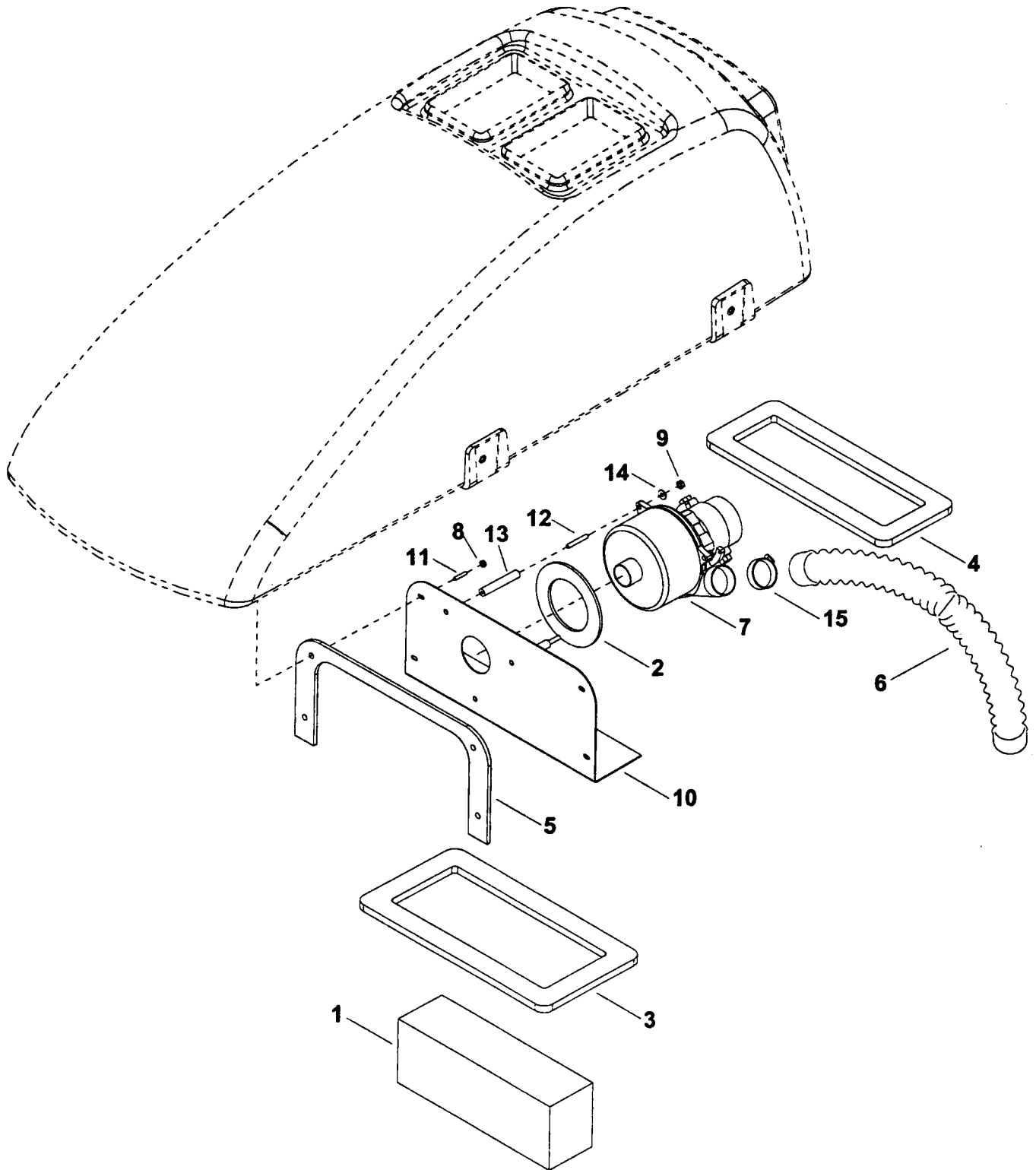

VACUUM GROUP

REF	PART	QTY	DESCRIPTION
1	E87632	1	Filter, Vacuum
2	E87467	1	Vac motor gasket WS28/32
3	E87672	1	WS28/32 recovery tank gasket
4	E87673	1	WS28/32 recovery tank gasket
5	E87749	1	Vac Mount Plate Gasket
6	39547	1	HOSE ASM, 1.5 BLK VAC X 21
7	E87634	1	Vac Motor ASM 24 VCD 3 Stage
-	E87236	-	Motor brush set
8	57104	4	NUT, 10-32 W/STAR WASHER PLTD
9	E85358	3	Nut
10	E87485	1	Vac mount plate WS28/32
11	70607	4	SET SCR, #10-32 X 1.00 SS
12	70638	3	SCR, 1/4-20 X 1.75 SSSCU
13	73566	3	SPACER, 1/2 OD X 3.0 W/1/4-20 AL
14	E87414	3	Washer

WHEELS AND FRAME GROUP

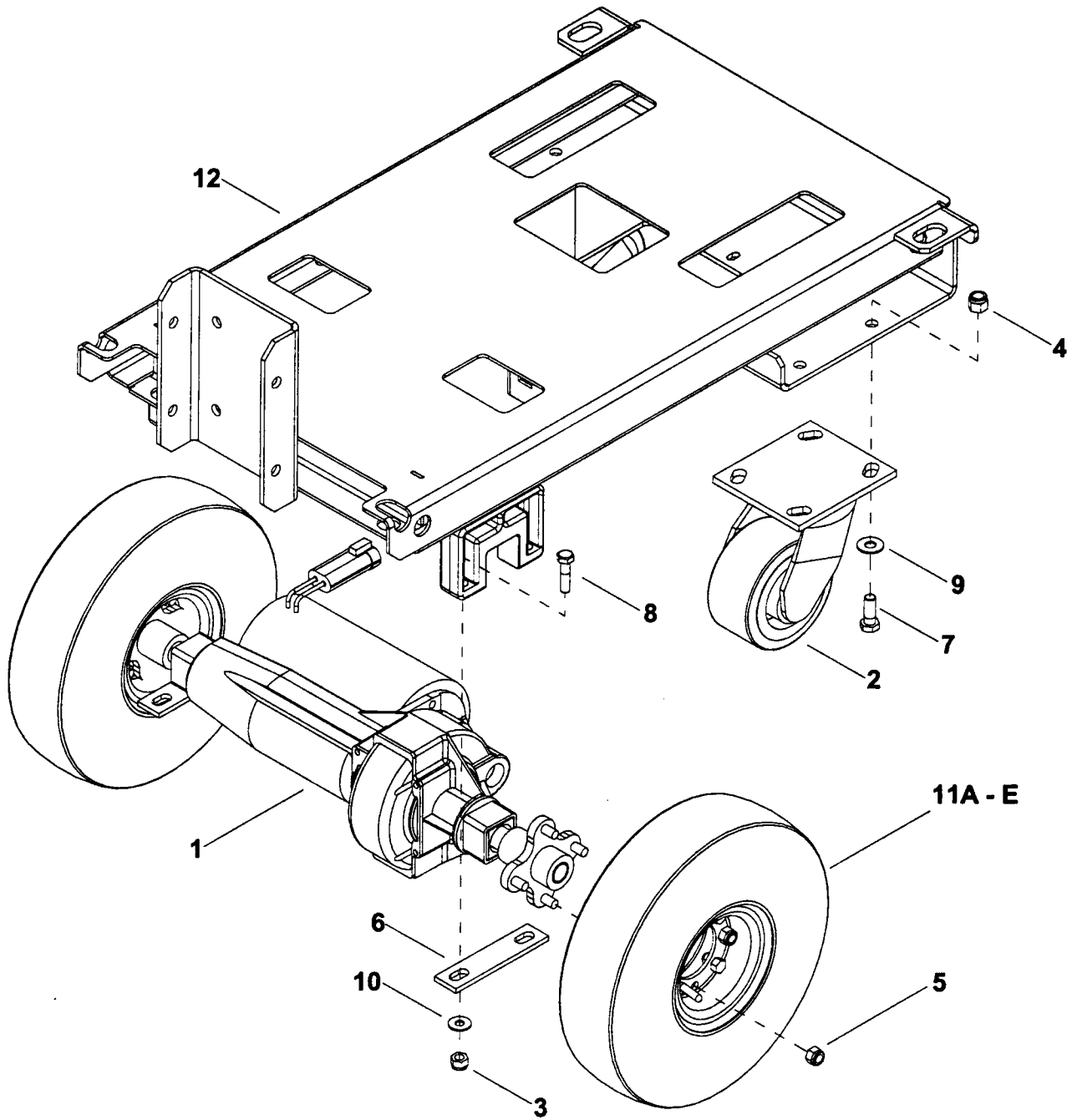

WHEELS AND FRAME GROUP

REF	PART#	QTY	DESCRIPTION
1	E87360	1	AXLE, MOTOR DRIVE 24 VDC
2	E87635	2	CASTER 4" DIA. X 2 X 3.56 R
3	E81063	4	NUT, 5/16-18 HEX NYLCK
4	E87636	8	NUT, 3/8-16 HEX NYLOCK
5	57128	8	NUT, 5/16-24 HEX NYLOCK
6	62714	2	PLATE, DRIVE AXLE
7	E87637	8	SCR, 3/8-16 X 1.00 HHCS GR5
8	E87239	4	SCR, 5/16-18 X 1.25 HHCS GR5
9	E87638	8	WASHER, 3/8 X 7/8 FLAT SS
10	87090	4	WASHER, 1/4 ID X 3/4 OD PLTD
11A	E87333	2	WHEEL, 10" PNEU. NON-MARKING
	78414	-	TUBE, 10" TIRE
11B	89175	-	WHEEL ASY, 10IN PNEU, BLACK
	78414	-	TUBE 10" TIRE
11C	E87474	-	WHEEL ASM, 10" SOLID SPCL SCBR
11D	E87735	-	WHEEL ASM, 10" FMFL N-MARKING
11E	89212	-	WHEEL ASM, 10" FMFL BLK KNOBBY
12	89190	1	WELDMENT, FRAME

WIRING GROUP – BATTERY CABLES

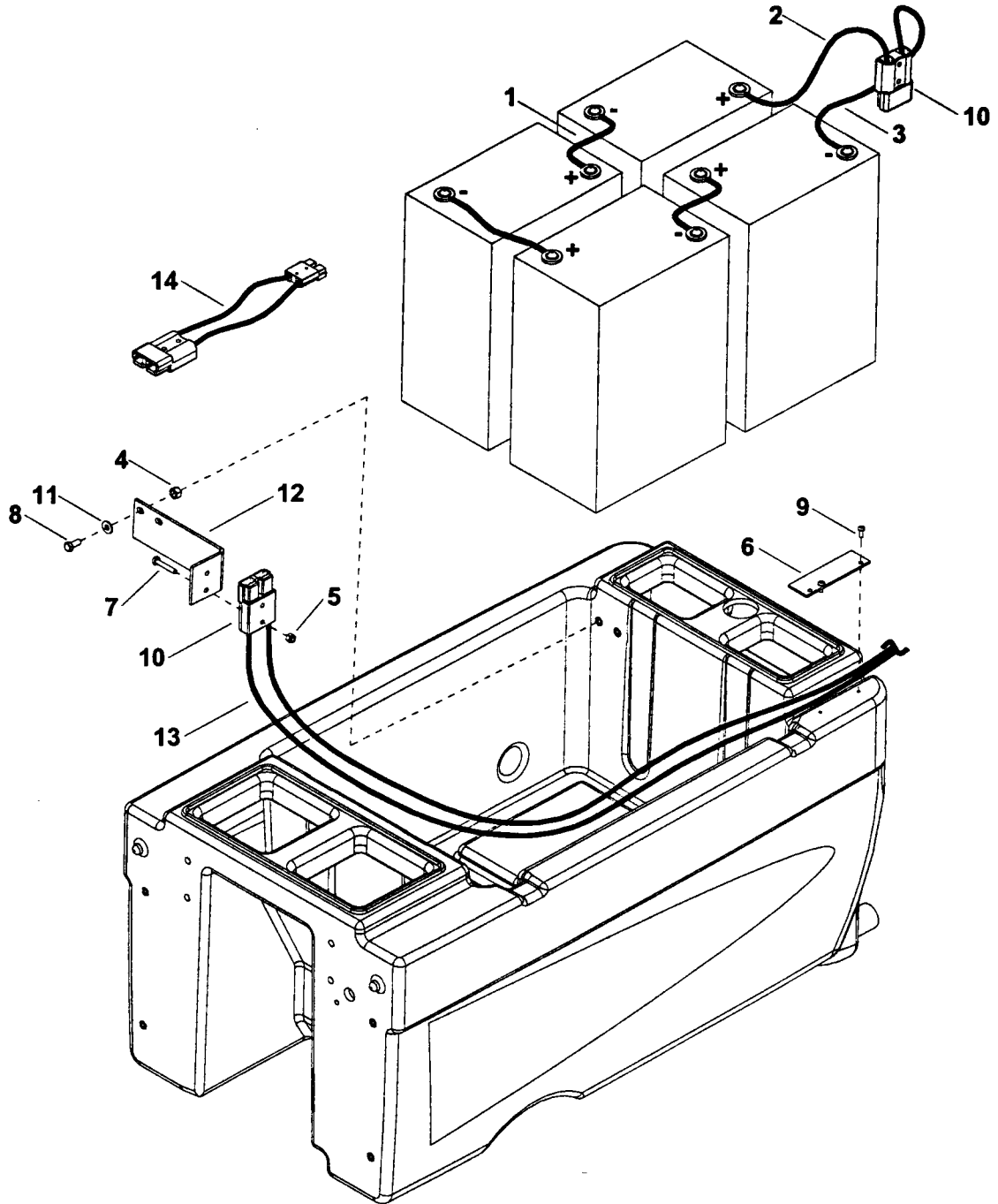

WIRING GROUP - BATTERY CABLES

REF	PART#	QTY	DESCRIPTION
1	E87639	3	WIRE, 4 X 158 CLAMP
2	E87640	1	CABLE, 4 X 27 RED
3	E87641	1	CABLE, 4 X 27 BLK
4	E87643	2	NUT 3/8-16 HEX
5	E87575	2	NUT, 1/4-20 HEX NYLOCK SS
6	62728	1	PLATE, CABLE MOUNT
7	70010	2	SCR, 1/4-20 X 1.5 HHCS SS
8	70302	2	SCR 5/16-18 X 1 "HHCSGR5PLT DL
9	70403	2	SCR, #10X1/2 PPHST TYPE B
10	E11410	2	CONNECTOR, RED 24V
11	E87623	2	WASHER, 5/16 FLAT SS
12	140322	1	BRKT, BATT CONNECTOR MOUNTING
13	880208	2	CABLE, ELECTRICAL 4GA X 80.0
14	E87734	1	WIRE ASM, CHARGER ADAPTER 24V

WIRING GROUP - CONTROL PANEL

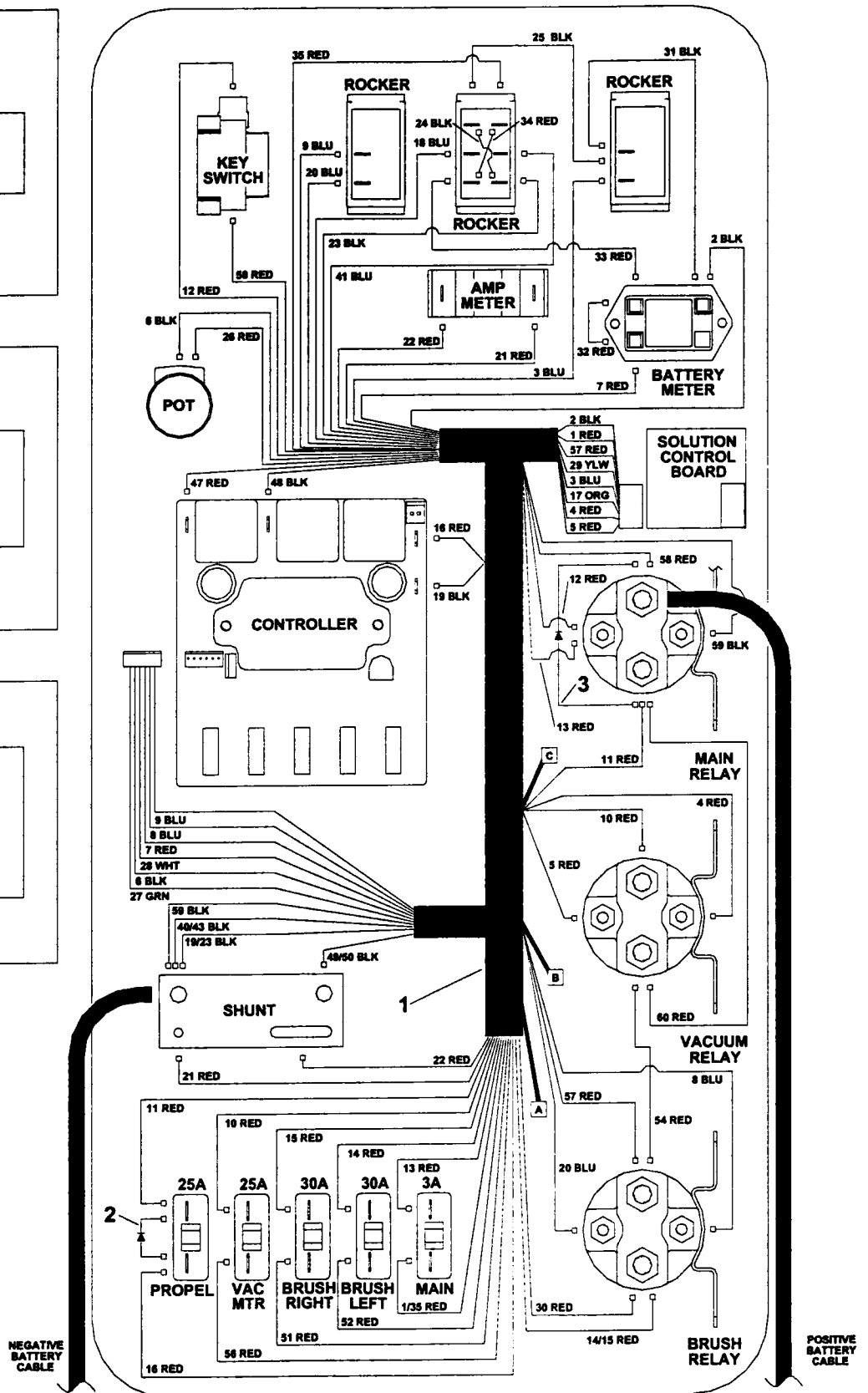
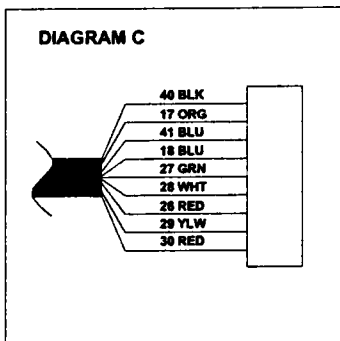
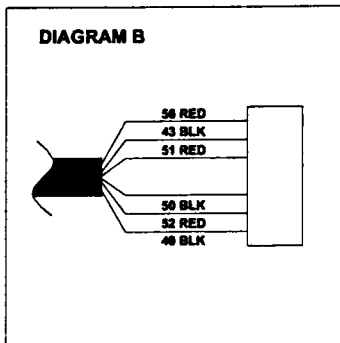
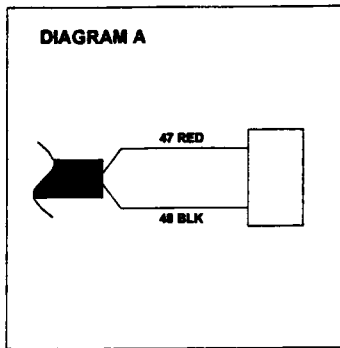

WIRING GROUP - CONTROL PANEL

REF	PART#	QTY	DESCRIPTION
1	E87495	1	HARNESS PANEL
2	29204	1	DIODE ASM, 76008 X 76008
3	E86717	1	DIODE ASM, 76075 X 76075

WIRING GROUP – MAIN HARNESS

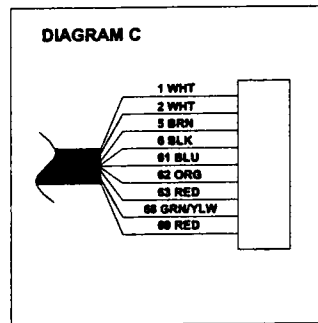
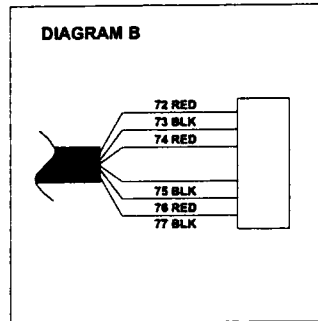
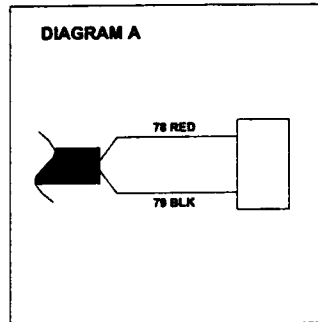
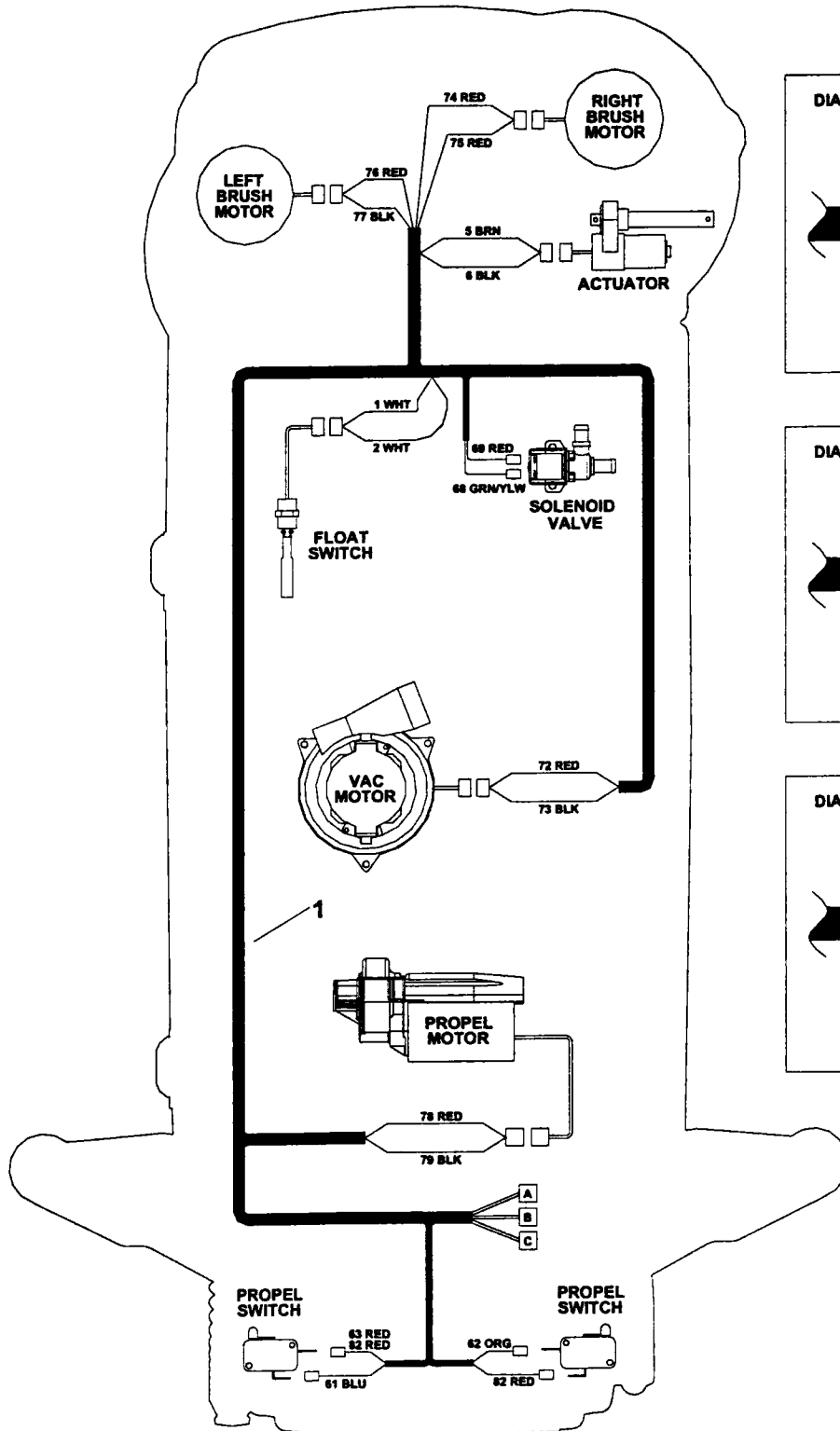

WIRING GROUP - MAIN HARNESS

REF	PART#	QTY	DESCRIPTION
1	E87494	1	HARNESS, MAIN

WIRING GROUP - SCHEMATIC

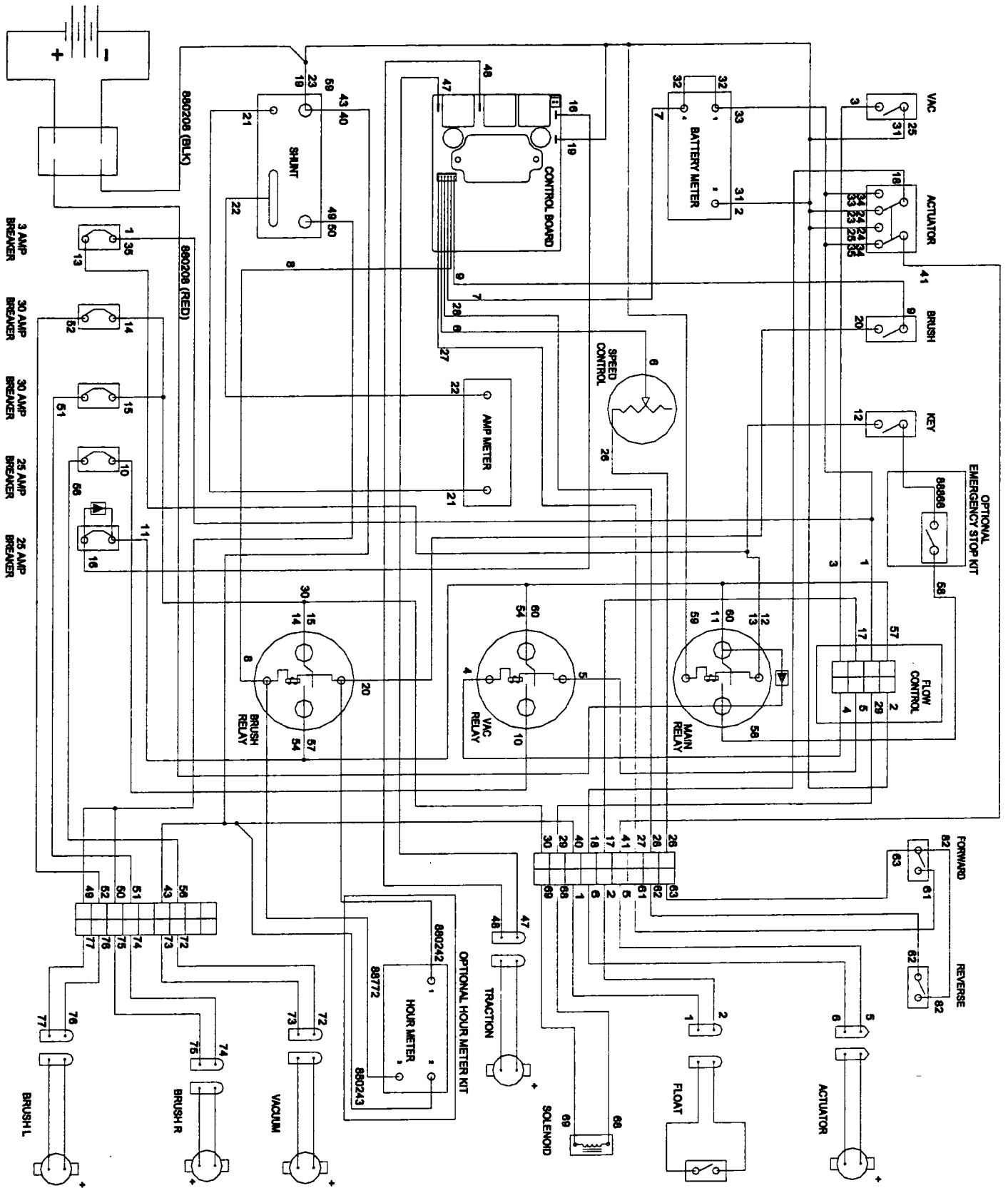

BETCO US WARRANTY POLICY

10 year coverage

Subject to the conditions stated below, Betco warrants parts and labor on rotationally molded polyethylene tanks/housings and injection molded vacuum head assemblies to be free from defects in materials and workmanship for a period of ten years to the original purchaser.

3 Year Coverage

Subject to the conditions stated below, Betco warrants parts and labor on all other Betco components to be free from defects in materials and workmanship for a period of three years to the original purchaser.

1 Year Coverage

Subject to the conditions stated below, Betco offers a limited warranty on parts and labor on the following equipment: parts and accessories to be free from defects in materials and workmanship for a period of one year to the original purchaser.

- DM Series Vacuums: #85506-00, #85507-00
- Bac Pac Lite Vacuum: #85903-00
- FiberPRO® Floor Dryer: #85507-00
- WORKMAN™ Series Vacuums: #85024-00, #85025-00, #85026-00, #85027-00
- CV100T Vacuum: #85023-00
- All Tools and Accessories
- All Battery Chargers
- All Batteries are pro-rated for 1 year

Allowable Travel Time Warranty Reimbursement:

Eligible equipment: All battery and propane powered equipment products. Warranty period: 90 days from date of sale to the original purchaser. A maximum 60 mile round trip at 44 cents per mile will be allowed for warranty consideration.

Propane Machine Warranty:

Honda engines are warranted by Honda for a period of 2 years against manufacturer defects. Kawasaki engines are warranted by Kawasaki for a period of 2 years against manufacturer defects. All other components (except wear items)* are warranted by Betco for a period of 3 years.

***Wear Items exempt from Warranty consideration include but may not be limited to: power cords, transport wheels, vacuum bags, belts, squeegee blades, pad drivers, clutch plates, handle grips, filters, screens, throttle cables, brushes and carbon brushes.**

Subject to the conditions and exceptions stated in this warranty, Betco warrants the Betco products to be free from defects in material and workmanship, under normal use and service, for the periods listed under the warranty policy to the original purchaser. At any time during the warranty period, Betco will furnish replacement parts for the Betco parts to the original purchaser. Such parts will be furnished and charged including transportation costs, to the original owner through any Betco authorized Service Distributor. If the original part is returned within the warranty policy period from date of delivery for inspection by Betco and is found to be defective the owner will be credited for the cost of replacement parts plus shipping and handling. Replacement parts that have become defective through wear or abuse are not included in this warranty.

This warranty does not apply to damage or defect caused by accident, misuse, negligence, fire, or to any Betco product which has been serviced or repaired by other than an authorized Betco Service Distributor or Betco factory personnel. This warranty is void if products are used for any purpose other than that which was intended. There are no other warranties expressed or implied. In no event shall Betco be liable for incidental or consequential damages or any damage to person or property. (Please note some states do not allow the exclusion or limitations for incidental and consequential damages)

