



E12603-00



XT3 27 27" Battery Burnisher









Operator's Manual Parts Schematic

Table of Contents

Page	Description
2	Table of Contents
3,4	Safety Instructions - Very Important - Must Read
5	Product Specifications
6	Procedures for Loading, Transporting, and Unloading Machine
7	Operating Instructions
8	Battery Charging
9	Battery Maintenance
10	Battery Charger Operation
11	Battery Charger Settings
12	Battery Discharge Indicator (BDI) & Hour Meter
13	Pad Changing Instructions
14	Machine Balancing Set Up
15	Belt Tensioning
16,17	Battery Water Filling
18,19	Covers & Handle Parts
20,21	Frame & Deck Parts
22,23	Belt Drive Parts
24,25	Pad Driver Parts
26,27	Battery & Electrical Parts
28	Battery Connections
29	Water Fill System
30	Electrical Layout
31	Wiring Ladder Diagram
32	Troubleshooting Guide
33	
34	Warranty

SAFETY INSTRUCTIONS

<u>Hazard Level</u>	<u>Explanation or Description of Hazard Level</u>
	Failure to follow safety instructions labeled  could result in severe injury or death to the machine operator or others.
	 could result in injury to the machine operator or others. Also, machine or property damage could occur.
	Failure to follow safety instructions labeled  could result in damage to the machine or other property.



This manual contains important information about your machine. Read and understand all instructions before operating the machine. Failure to read and follow the instructions could result in injury to the person operating the machine or injury to others. Damage to the machine or other property could occur if instructions are not followed.



Do not operate this machine around any solvents, thinners, or other flammable liquids or materials. Electrical sparks can cause a fire or even an explosion.



Do not smoke around the machine. Also, keep all sparks and flames away from the batteries. The batteries generate gases that can cause an explosion.



Special care needs to be used when working on or near the batteries. Wear eye protection. Do not lay tools on batteries, as they may short out battery terminals. Do not wear metal jewelry, as it may short out battery terminals.



Charging batteries can be dangerous. Be aware that the battery charger may have a relatively low voltage output, but the current output is very high and therefore dangerous. Do not operate the charger if any parts of the charger or charger cords are damaged. Do not stand on a wet floor when connecting or disconnecting charger to the power outlet or to the machine.

Safety Instructions are continued on the next page 

SAFETY INSTRUCTIONS



Battery acid is dangerous. Wear eye and face protection, hand protection, and body protection when working on and around batteries. If you get acid on your skin, wash off immediately. If you get acid on your clothing, remove clothing and wash any skin that was in contact with the clothing. Baking soda mixed with water will help to neutralize the acid on your skin.



The machine is very heavy, so be very careful when loading, transporting, and unloading the machine.



Keep all body parts, clothing, and objects away from moving parts.

Operate machine from the rear, not from the side.



Disconnect a wire to the batteries before working on the machine.



Do not operate machine with charger plugged in.



Do not operate machine with any parts damaged or missing.



Do not operate close to stairs, loading docks, or other drop-offs. Do not park machine in such a manner that it could roll, forward or backward, off a drop-off.



Authorized personnel must perform maintenance and repairs. Do not alter or modify the machine, unless authorized by the manufacturer.



Do not expose the electrical components to water or excessive moisture.



Always put caution signs around the areas that are being cleaned.



Do not use machine as a "ladder". Do not use machine as a "forklift" to push stuff around. Do not ride or let anyone ride on the machine.



Your machine warranty may be voided if parts other than PowerBuff parts are used.

XT3 - 27 Product Specifications

Burnish path:	27"
Pad size:	27"
Motor:	Maintenance Free, brushless, rated at 5 hp.
Motor controller:	Monitors and maintains consistent pad speed and torque
Motor speed:	2000 rpm
Pad pressure:	Approx. 30 lbs.
Pad driver:	Flexible, Flex Lock III
Center lock:	Threaded, for easy installation
Noise level:	70 dB (at operator)
Voltage:	36 volt system
Batteries:	(6) Lead Acid, 6 volt, 226 Amp Hour, Wet Cell
Run time:	Up to 2.5 hours
Charger:	Onboard, high frequency computer controlled
Battery/hour meter gauge:	Yes, BDI (battery discharge indicator) computer controlled
Key switch:	Yes.
Main power light:	Yes, bright red
Safety switch:	Yes, spring loaded handle assembly
Length:	68"
Width:	30"
Height:	40.5"
Weight:	616 lbs.
Tank Construction:	Polyethylene
Deck Construction:	Cast Aluminum
Wheels:	(2) 6" heavy duty, non-marking, sealed bearings
Casters:	(2) 3" heavy duty, non-marking
Productivity:	Up to 36,000 sq.ft/hr.

Procedures for Loading, Transporting, and Unloading Battery Burnisher

DANGER: The machine is very heavy, so be very careful when loading, transporting, and unloading the machine. Use at least two people to load or unload the machine.

- Loading Procedure Using a Ramp

- a) It is not recommended that the battery burnisher be loaded using a ramp with an incline of more than 7 degrees. The machine is not self-propelled and therefore it is not able to assist itself up a ramp. It is too heavy to manually push up a steep incline.
- b) If you must load with a ramp, the incline must be no more than 7 degrees. (This would permit a height of no more than one foot for an 8-foot ramp).
- c) Ramp must be secured to vehicle, and be clean and dry.
- d) Machine must be pushed or pulled straight up the ramp and never at an angle.

- Loading Procedure Using a Lift Gate

- a) Lift gate must have ample capacity to lift the burnisher.
- b) Wheels must be firmly chocked to prevent burnisher from rolling off the lift gate.

- Securing Battery Burnisher

- a) Burnisher must be secured, so that it will not roll or turn over. Use chocks and tie downs to secure.
- b) Please be aware that the battery burnisher is very heavy, and that a metal bulkhead in a van may not contain equipment in the event of an accident. The equipment in a van can be more dangerous than the accident itself.

- Unloading Procedure Using a Ramp

- a) Ramp must be long enough so that removal can be controlled. Use same ramp incline restrictions as used for loading burnisher.
- b) Ramp must be secured to vehicle, and be clean and dry.
- c) Machine must be taken straight down the ramp and never at an angle.
- d) Do not let machine run over you or anyone else as it comes off ramp.

OPERATING INSTRUCTIONS

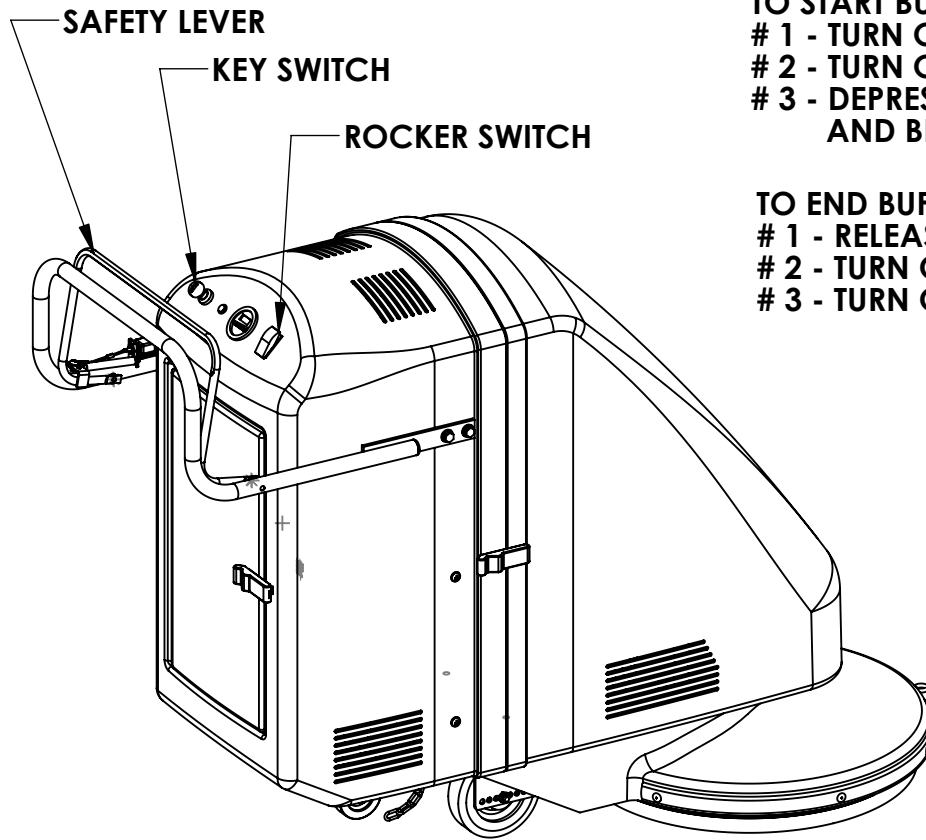

TO START BUFFING:
1 - TURN ON KEY SWITCH
2 - TURN ON ROCKER SWITCH
3 - DEPRESS SAFETY HANDLE
AND BEGIN BUFFING

TO END BUFFING:
1 - RELEASE SAFETY HANDLE
2 - TURN OFF ROCKER SWITCH
3 - TURN OFF KEY SWITCH

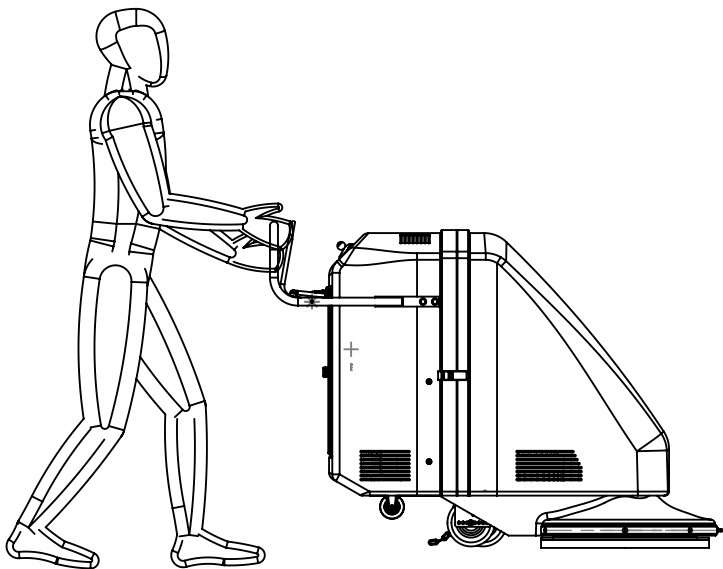

AFTER EACH USE:
PLUG CHARGER CORD
INTO 110 VOLT WALL OUTLET

BATTERY CHARGING

REFER TO NEXT THREE PAGES FOR BATTERY CHARGER OPERATION AND BATTERY MAINTENANCE

- Become familiar with and follow the instructions issued by the charger manufacturer.
- Batteries should be charged after each period of use. Lead acid batteries do not develop a memory and need not be fully discharged before recharging.
- The charger is factory set to properly charge the size and type batteries that were supplied with your machine.
- Charge only in well-ventilated area. Keep sparks or flames away from a charging battery.
- Do not get the charger wet.
- Do not remove battery caps, the caps are vented. Caps on standard wet cell batteries. No caps on AGM batteries.
- Do not charge machine in a wet area.
- Do not stand in a wet area when plugging in charger to the 110 volt receptacle.
- Plug in the charger to a properly grounded 110 volt receptacle.
- Lights will indicate the charging status.
- Charger will shut off automatically when batteries are fully charged.

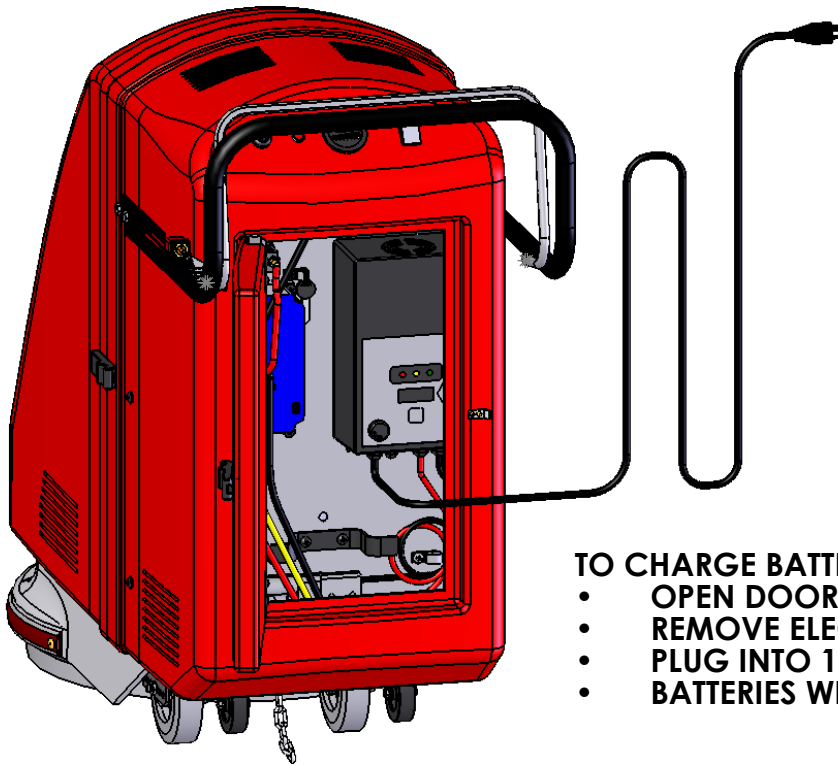

TO CHARGE BATTERIES:

- OPEN DOOR
- REMOVE ELECTRICAL CORD
- PLUG INTO 110 VOLT OUTLET
- BATTERIES WILL BEGIN CHARGING

BATTERY MAINTENANCE

IMPORTANT!!! READ ALL SAFETY INSTRUCTIONS ON PAGES 4 AND 5

FOR ALL BATTERIES - STANDARD WET CELL AND AGM (ABSORBED GLASS MAT)

- Batteries should be charged as soon as possible after each period of use. The batteries in this machine do not develop a memory and do not need to be fully discharged before recharging. Do not allow batteries to remain in a discharged state.
- Be aware that a discharged battery will freeze easily.
- Make sure battery connections are tight and free from corrosion. A baking soda and water solution and a wire brush are helpful when cleaning battery connections. Keep caps on when cleaning batteries, so that electrolyte is not contaminated.

FOR WET CELL BATTERIES

- Check the electrolyte level weekly. Top off with distilled water as shown in figure 2. Do not overfill. Make sure that all plugs are tight.
- Water should always be added after fully charging the battery, although prior to charging, there should be enough water to cover the plates. This also applies if the batteries have a watering system.

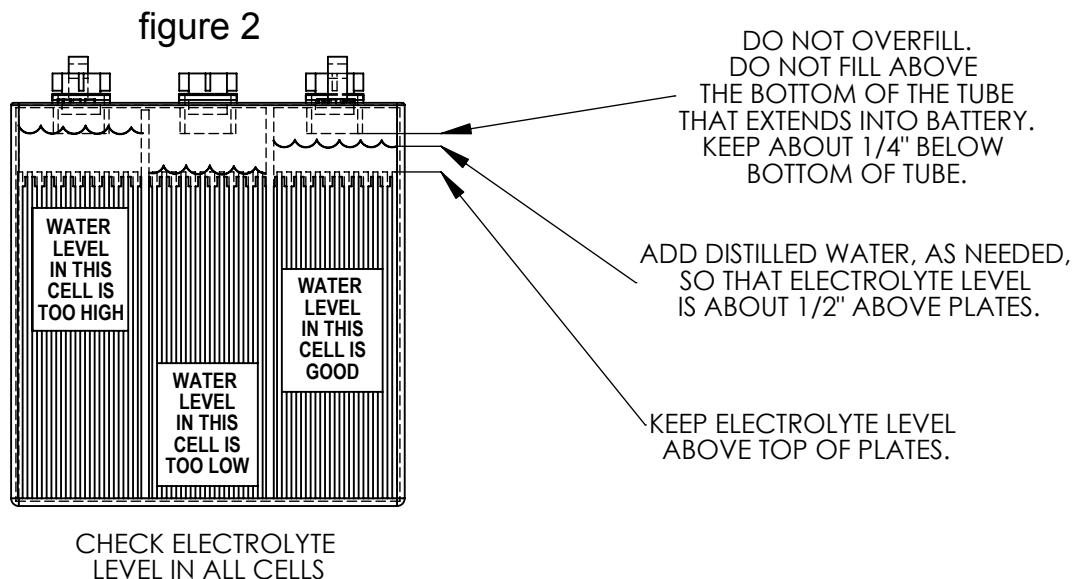

!!! BATTERIES ARE DANGEROUS !!!
READ THE SAFETY INSTRUCTIONS
IN THE FRONT OF THIS MANUAL
FOR SPECIFIC WARNINGS

IF YOU WOULD LIKE TO LEARN MORE ABOUT BATTERIES

THERE IS A VERY INFORMATIVE PUBLICATION AVAILABLE. IT COVERS SUBJECTS SUCH AS BATTERY TERMS AND HOW A BATTERY WORKS TO SPECIFIC GRAVITY TESTING WITH A HYDROMETER AND DIAGNOSIS OF BATTERY PROBLEMS.

YOU CAN OBTAIN A COPY OF THE "**BATTERY SERVICE MANUAL**" FROM

BATTERY COUNCIL INTERNATIONAL
401 N. MICHIGAN AVENUE
CHICAGO, IL 60611
PHONE 312-644-6610

BATTERY CHARGER OPERATION

OPERATION

- **PLUG THE CORD FROM THE CHARGER INTO A 110 VOLT OUTLET**
 - Batteries should now start charging.
- A test is run on the battery voltage to decide if the charging process should be started or not. If the battery is not connected to the battery charger, the display will show the word "bat". The word will stay on, even if the test is failed (for instance, reversed polarities or incorrect battery connection). If the test is passed, the display will show the battery voltage for approximately 5 seconds and the battery will begin to be charged. The charging cycle progress will be shown by red, yellow, and green LED indicators. At the end of the charge, when the green indicator is on, unplug the cord from the socket and operate the machine.
- **NOTE: THE MACHINE WILL NOT POWER ON IF THE CHARGER IS STILL PLUGGED IN TO THE 110 VOLT OUTLET.**

INDICATOR LIGHTS

- Red indicator shows that the charging cycle has started.
- Yellow indicator shows that the final phase of the charging cycle has started.
- Green indicator shows that the charging cycle has finished.

DISPLAY

Press button "S" (for Selection) to display:

- A = the charging current,
- U = the battery voltage,
- h = the charging time,
- C = the charging ampere-hours [Ah],
- E = the energy used [KWh].

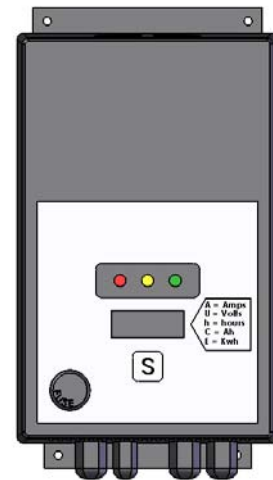

CAUTION - CHARGER SETTINGS MUST BE CHANGED IF BATTERY TYPE IS CHANGED (SEE NEXT PAGE FOR SETTINGS)

THIS BATTERY CHARGER IS FACTORY SET FOR THE TYPE OF BATTERIES THAT CAME WITH YOUR MACHINE. IF YOU SWITCH BATTERY TYPES (FOR EXAMPLE GO FROM AGM TYPE BATTERIES TO STANDARD WET CELL BATTERIES), THEN THE BATTERY CHARGER MUST BE REPROGRAMMED. SEE NEXT PAGE "HOW TO SET THE CHARGER FOR DIFFERENT SIZES AND TYPES OF BATTERIES" FOR INSTRUCTION.

GENERAL INFORMATION AND WARNINGS

- **READ SAFETY INSTRUCTIONS ON PAGES 4 AND 5**
- This is a state-of-the-art electronic high frequency automatic battery charger with microprocessor.
- It is suitable for any battery type, if the charger has the proper settings. (Call manufacturer of machine on how to set the charger for different batteries than were supplied with your machine)..
- Never disconnect the battery while charging, since this could cause sparks.
- Never use the equipment in the rain, in areas used for washing, or in wet or damp areas.
- Use battery chargers only in well ventilated areas.

FOR LEAD ACID BATTERIES:

- Control the water level after each charging process. (See "Battery Maintenance" page).
- Refill with distilled water only.
- Caution! The gases generated during charging are explosive. Do not smoke in the vicinity of the batteries. When working with cables and electrical equipment, avoid open flames and sparks.
- Attention: Use protective glasses and gloves during battery maintenance. Battery acid causes injuries. In case of contact with battery acid, wash the affected parts with a lot of fresh water and consult a doctor if necessary.

HOW TO SET THE CHARGER FOR DIFFERENT SIZES AND TYPES OF BATTERIES



THE INFORMATION THAT FOLLOWS IS PROVIDED SHOULD YOU EVER CHANGE THE TYPE OR SIZE OF BATTERIES IN YOUR MACHINE. CONSULT WITH THE EQUIPMENT MANUFACTURER BEFORE YOU MAKE ANY CHANGES TO THE CHARGER SETTINGS. DAMAGE COULD OCCUR TO THE BATTERIES AND MORE SERIOUS, IF THE BATTERIES ARE CHARGED TO THE INCORRECT AMPERAGE OR VOLTAGE, THE BATTERIES COULD EXPLODE.

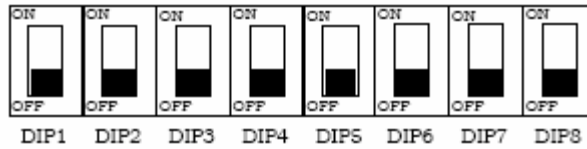

UP IS ON

DOWN IS OFF

DIP SWITCHES ARE LOCATED UNDER LABEL

DIP 1, DIP 2, DIP 3, AND DIP 4 ARE FOR SELECTING THE CHARGING CURVE

DIP 1	DIP 2	DIP 3	DIP 4	CHARGING CURVE
OFF	ON	ON	ON	WET BATTERIES
OFF	ON	OFF	ON	AGM BATTERIES
PLEASE CONSULT EQUIPMENT MANUFACTURER BEFORE CHANGING				

DIP 5 AND DIP 6 ARE CONTROL THE CHARGING CURRENT

DIP 5	DIP 6	AMPERAGE
ON	ON	15 A
OFF	ON	20 A
ON	OFF	25 A
OFF	OFF	30 A

DIP 7 AND DIP 8 CONTROL THE BATTERY CHARGING VOLTAGE

DIP 7	DIP 8	VOLTAGE
ON	ON	12 V
OFF	ON	24 V
ON	OFF	36 V
OFF	OFF	48 V

BATTERY DISCHARGE INDICATOR (BDI) AND HOUR METER

Connector pin configuration (B)

- 1: hour meter input -
- 2: key +
- 3: relay +
- 4: relay -
- 5: battery -
- 6: not used
- 7: not used
- 8: battery +

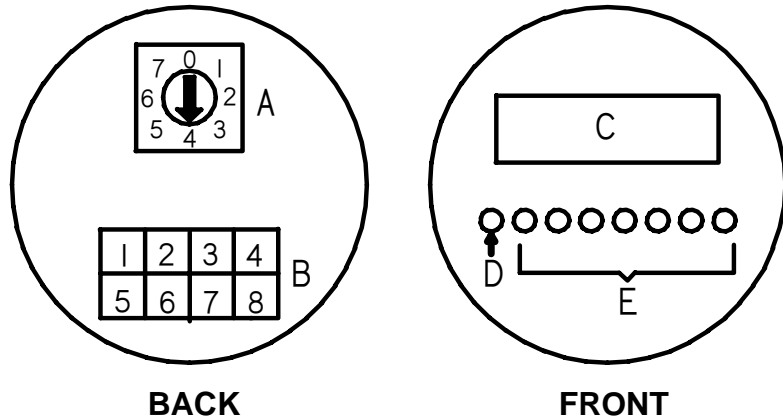

- A. Shutoff voltage rotary dipswitch. Factory set to 4 (32.76 volts). This is the voltage at which the batteries are 80% discharged. Do not set below this voltage or battery life will be shortened.
- B. Connections to meter (molex connector)
- C. Hour meter (display is always on, but only counts time when negative voltage is applied to pin 1)
- D. Low voltage shutoff LED
- E. Battery condition LED's. (1 through 7 with 7 being fully charged batteries)

POSITION	0	1	2	3	4	5	6	7
VOLTS PER CELL	1.63	1.68	1.73	1.76	1.82	1.84	1.86	1.89
TOTAL VOLTS	29.34	30.24	31.14	31.68	32.76	33.12	33.48	34.02

BDI DISPLAY

When the machine is turned on, the battery level indicator is switched on and the LED (D or E) corresponding to the position currently held by the rotary dipswitch will turn on. Position 0 (zero) corresponds to the red LED (D), position 1 corresponds to the first yellow LED (row of 7 LED's (D), and so on. After that, all the LED's turn on for a few seconds (lamp test) and then ordinary operation is started. The battery level indicator features two voltage thresholds: the stopping threshold and the resetting threshold. The stopping threshold corresponds to the value of the voltage at the end of discharge and depends on the position of the rotary dipswitch (A) located at the back side of the indicator. The resetting threshold corresponds to the reset-point threshold of the device (this value varies along with the discharging current selected by the dipswitch (A) and is close to the battery nominal value). When the voltage value corresponding to the stopping threshold is reached, the last yellow LED will flash for 15 seconds, then the red LED will turn on, and the blocking relay will open. To reset, switch off the battery level indicator, charge the batteries, and then switch on the machine.

BDI OPERATION

When the battery level indicator is switched on, the battery voltage is measured, and:

- If the voltage is below the stopping voltage, the machine will not run.
- If the voltage is higher than the resetting threshold, all the LED's will turn on again and the battery level indicator will reset and the machine will run.
- If the voltage ranges between the stopping voltage and the resetting voltage, the LED's will turn on rapidly according to the condition prior to the switching off. If the previous condition was a stop, the last yellow LED will flash.

PAD CHANGING INSTRUCTIONS

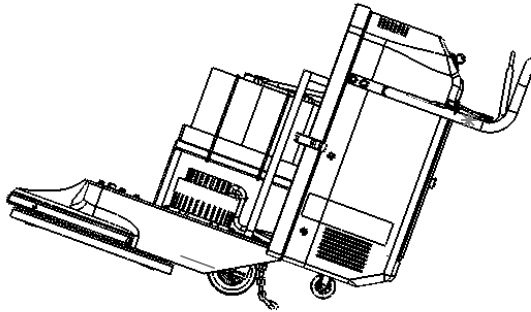

TILT MACHINE BACK AND REMOVE FRONT COVER

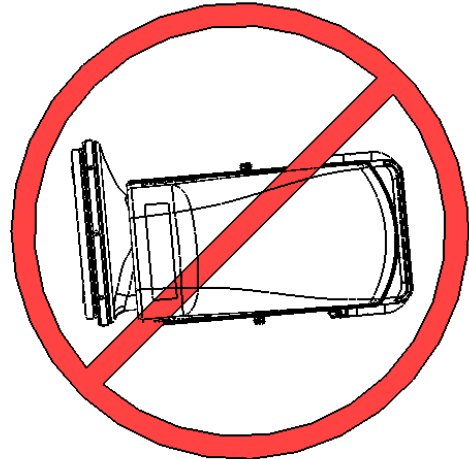

DO NOT TILT MACHINE ON ITS SIDE

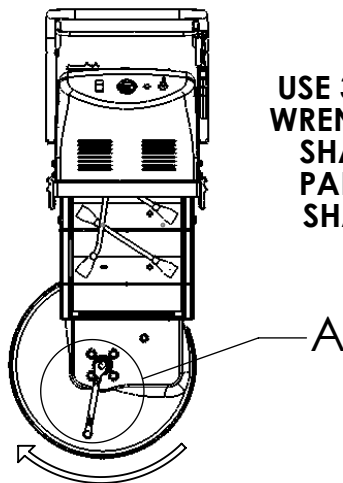

USE 3/4" OPEN END WRENCH TO SECURE SHAFT AND SPIN PAD DRIVER OFF SHAFT BY HAND

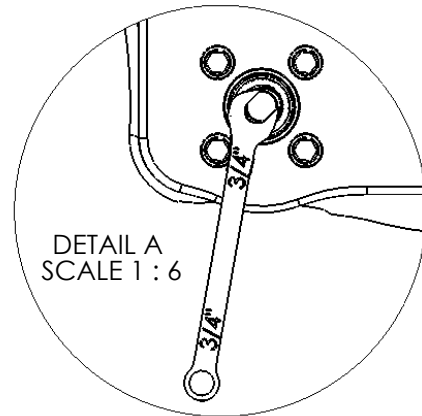

DETAIL A
SCALE 1 : 6

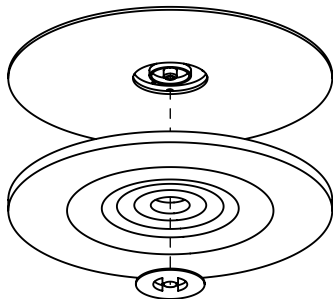

CENTER THE PAD ON PAD HOLDER AND TIGHTEN CENTER LOCK

USE THE HI-SHINE LIGHT BURNISH PAD
21" IS PART NUMBER F084621 (5 PER CASE)
27" IS PART NUMBER F084627 (5 PER CASE)

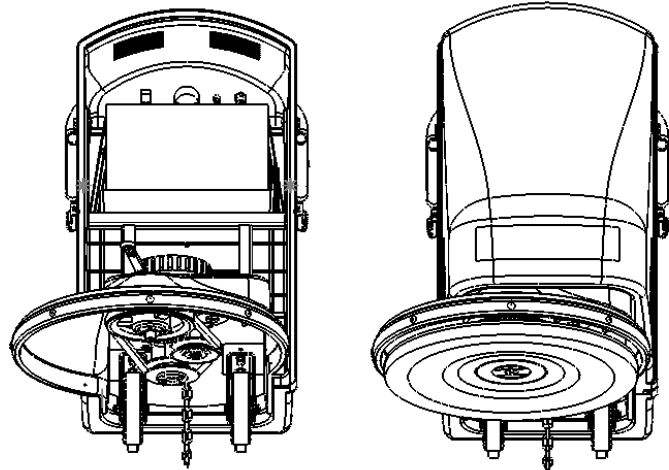

SPIN PAD DRIVER BACK ONTO SHAFT AND REPLACE COVER

NOTE: PAD CAN BE CHANGED ON THE MACHINE WITHOUT REMOVING PAD DRIVER, BUT YOU MUST GET ON THE FLOOR AND BE SURE THAT PAD IS CENTERED ON PAD DRIVER.

BALANCING INSTRUCTIONS

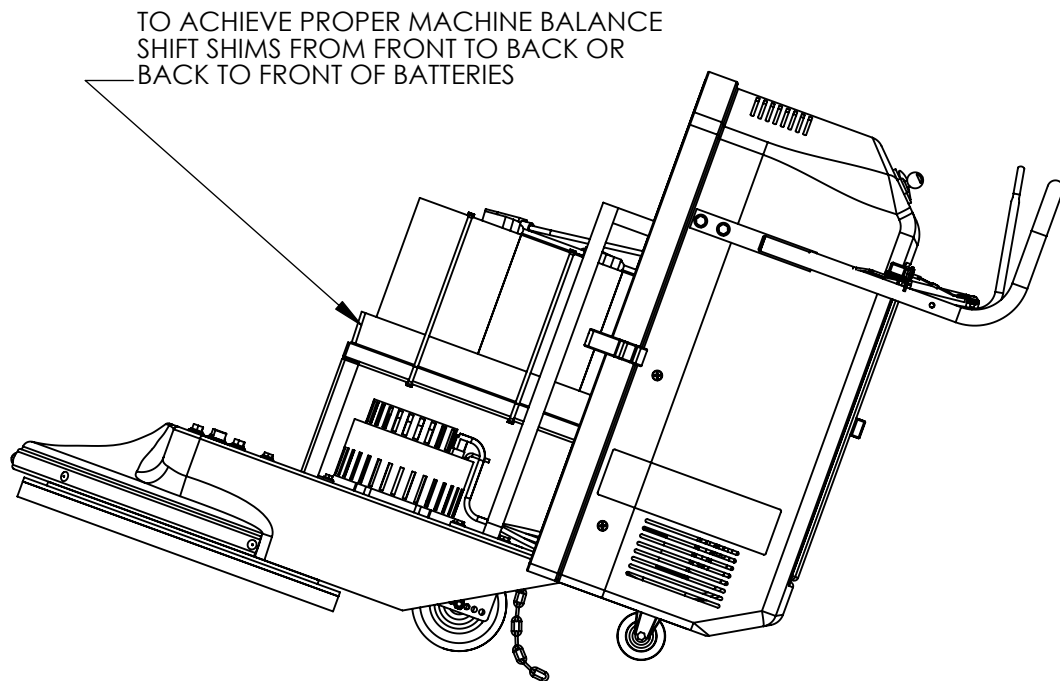

For best operation and maximum battery life, the XTG3 battery burnisher must have the correct pad pressure. The burnisher should require only minor adjustments to the balance. Only the battery shims should be adjusted. The wheel axel positions are factory set and are in the proper locations in the wheel brackets.

Tilt the burnisher back. Remove front cover.
Tilt burnisher to upright position.

With a new pad, the burnisher should hesitate and then barely fall back.
With a worn pad, the burnisher should barely sit upright.

If burnisher falls back easily, then the batteries need to be moved forward.

- Remove several battery spacers from front of batteries
- Slide batteries forward
- Add spacer(s) to rear of batteries
- Slide batteries tight against rear spacers (can be done by tilting machine back quickly)
- Replace remaining spacers in front of batteries (batteries should now be "locked" into position)

If burnisher sits upright easily, then the batteries need to be moved back.

- Remove some battery spacer(s) from rear of batteries
- Slide batteries back
- Replace remaining spacers in front of batteries (batteries should now be "locked" into position)

If batteries are moved as far as possible and proper balance cannot be achieved, then one of the wheels may be moved to achieve balance. The burnisher is factory balanced, so this is usually not necessary unless different batteries are installed by the customer. Most of the time, only one wheel needs to be moved. Any stagger of the wheels should have the left wheel in front (to the front of the machine) of the right wheel.

XT3-27 BELT TENSIONING INSTRUCTIONS

figure 2
DETAIL VIEW OF BELT AND TENSIONER

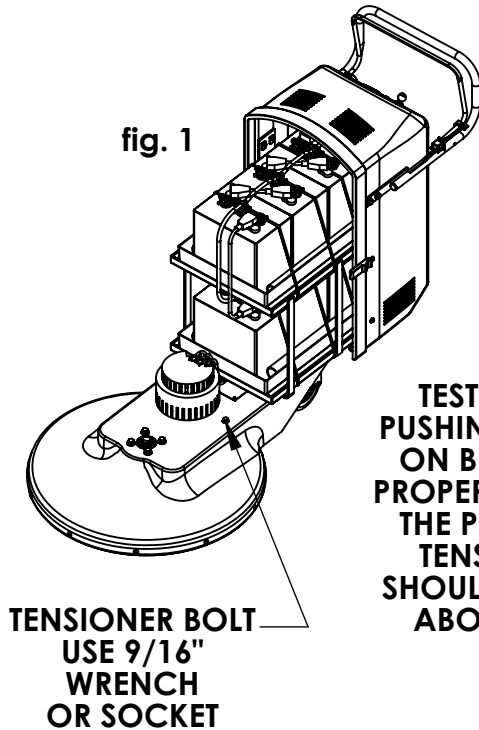

TEST TENSION BY
PUSHING OR PULLING
ON BELT. WITH BELT
PROPERLY TENSIONED,
THE PULLEY ON THE
TENSIONER ARM
SHOULD MOVE ONLY
ABOUT AN INCH.

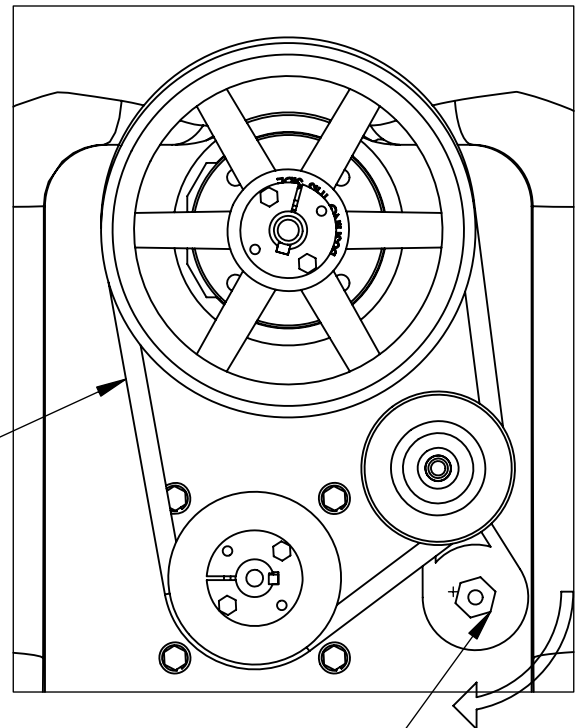

USE 15/16 SOCKET WITH EXTENSION
TO TIGHTEN TENSIONER IN DIRECTION
SHOWN TO PUSH INSIDE OF BELT OUT

TO TIGHTEN THE BELT TENSIONER

(Tensioner may have slipped, or belt may have stretched)

1. Tilt machine back and remove front cover
2. Using a 3/4" open end wrench, secure the top of the shaft and remove pad driver assembly. (see "Pad Changing Instructions" page)
3. On the top of the deck, use a 9/16" wrench or socket to loosen tensioner bolt. Leave a little snug to help hold tensioner in place after adjustment. (location shown in fig. 1)
4. Using a 15/16" socket with an extension, fully tighten tensioner from the underside of deck, and back off 10 to 15 degrees. This will be about 2 inches at the end of the socket handle. (Note: This is about one mark on the tensioner. There are five marks on the side of the tensioner, which are difficult to see with the tensioner in place. Each mark is equal to about 15 degrees. This leaves the tensioner at about 60 degrees of tightness.)(see figure 2)
5. While holding position tensioner in this proper location, fully tighten the tensioner bolt from the top. **TIGHTEN SECURELY!**
6. Make sure tensioner did not slip by pushing or pulling on side of belt away from tensioner. Belt should be tight and move the tensioner arm 10 to 15 degrees (about 1 ").

WATERING SYSTEM INSTRUCTIONS

FOR 6 VOLT WET CELL BATTERIES

PLEASE REFER TO SEPARATE

“PRO-FILL ON-BOARD WATERING SYSTEM”

MANUAL FOR DETAILED INFORMATION

BATTERY FILL INSTRUCTIONS

- Connect the hose to a dedicated hose bibb.
- After installing, purge the air out of the hose. Purging is necessary after the Millennium SPW™ system is installed and each time that the system is disconnected and reconnected to the hose bibb. See included Purge Procedure instructions.

PURGING IS REQUIRED BEFORE FIRST USE, OR IF HOSE ASSEMBLY HAS BEEN REINSTALLED SINCE LAST USE
(See next page and separate manual)

- **REFILL BATTERIES AFTER THEY HAVE BEEN CHARGED.** One watering per week is usually enough. Firmly mate the quick coupler. When the connection is made the red balls in the Flow Indicator will start rotating indicating water is flowing into the battery cells.
- After the Flow Indicator balls stop rotating, immediately disconnect by
- pushing the CPC button in and pulling the male Quick Coupler out.
- Put the dust cover back on the battery's male Quick Coupler.
- Store hose out of traffic area when not in use.

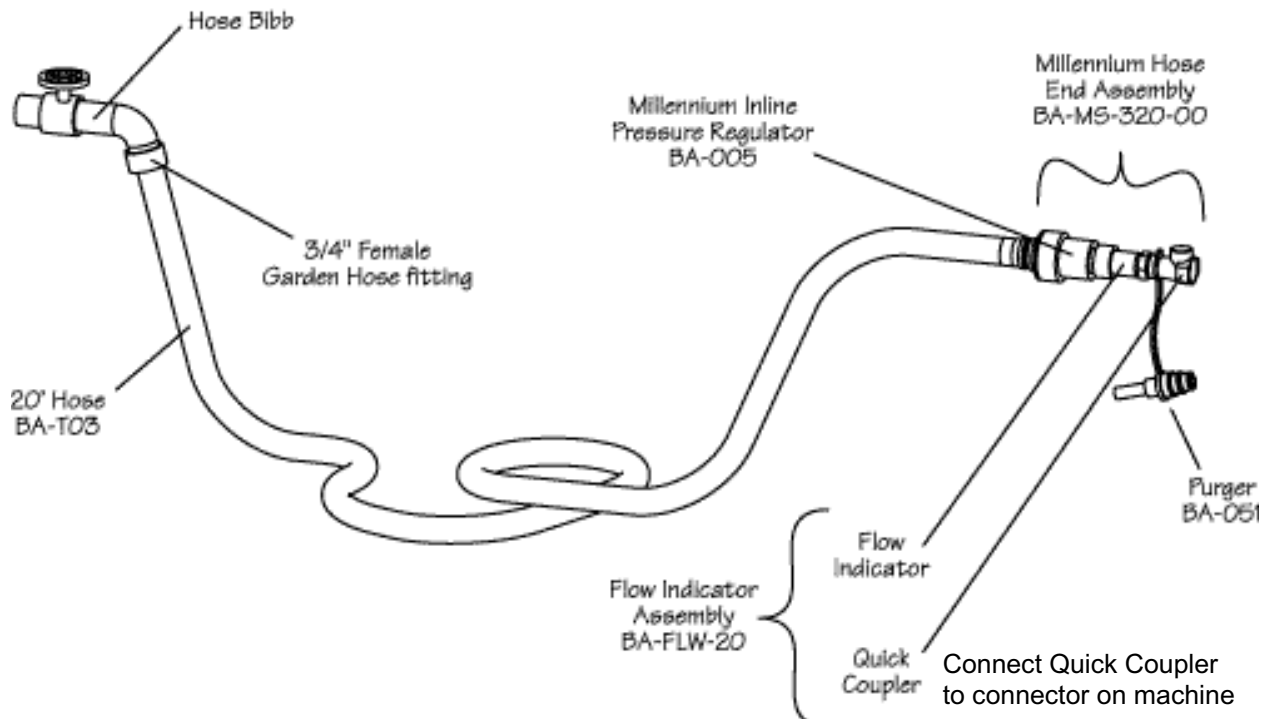

WATERING SYSTEM INSTRUCTIONS

FOR 6 VOLT WET CELL BATTERIES

PLEASE REFER TO SEPARATE

“PRO-FILL ON-BOARD WATERING SYSTEM”

MANUAL FOR DETAILED INFORMATION

PURGING INSTRUCTIONS

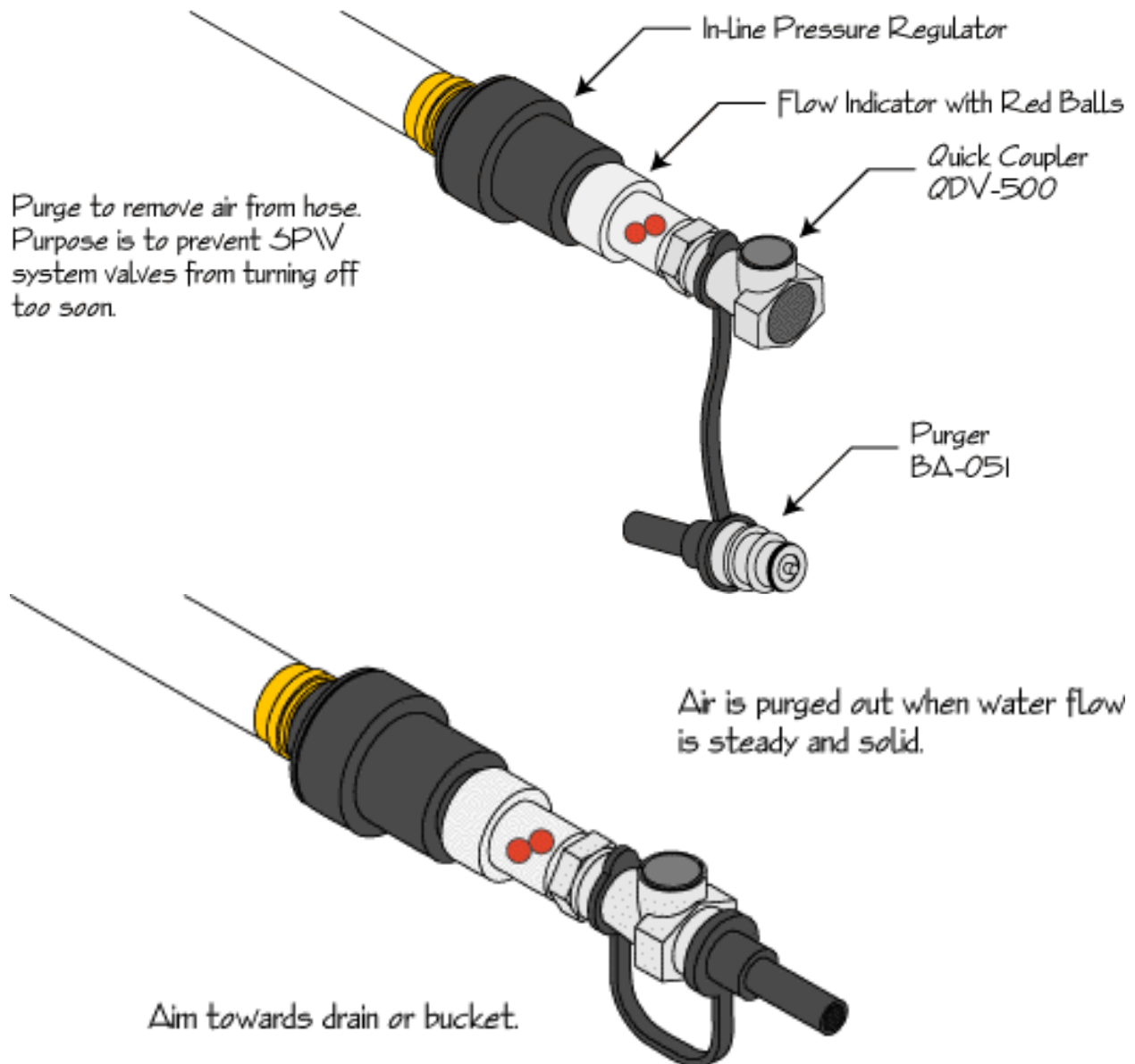

Covers & Handle Parts

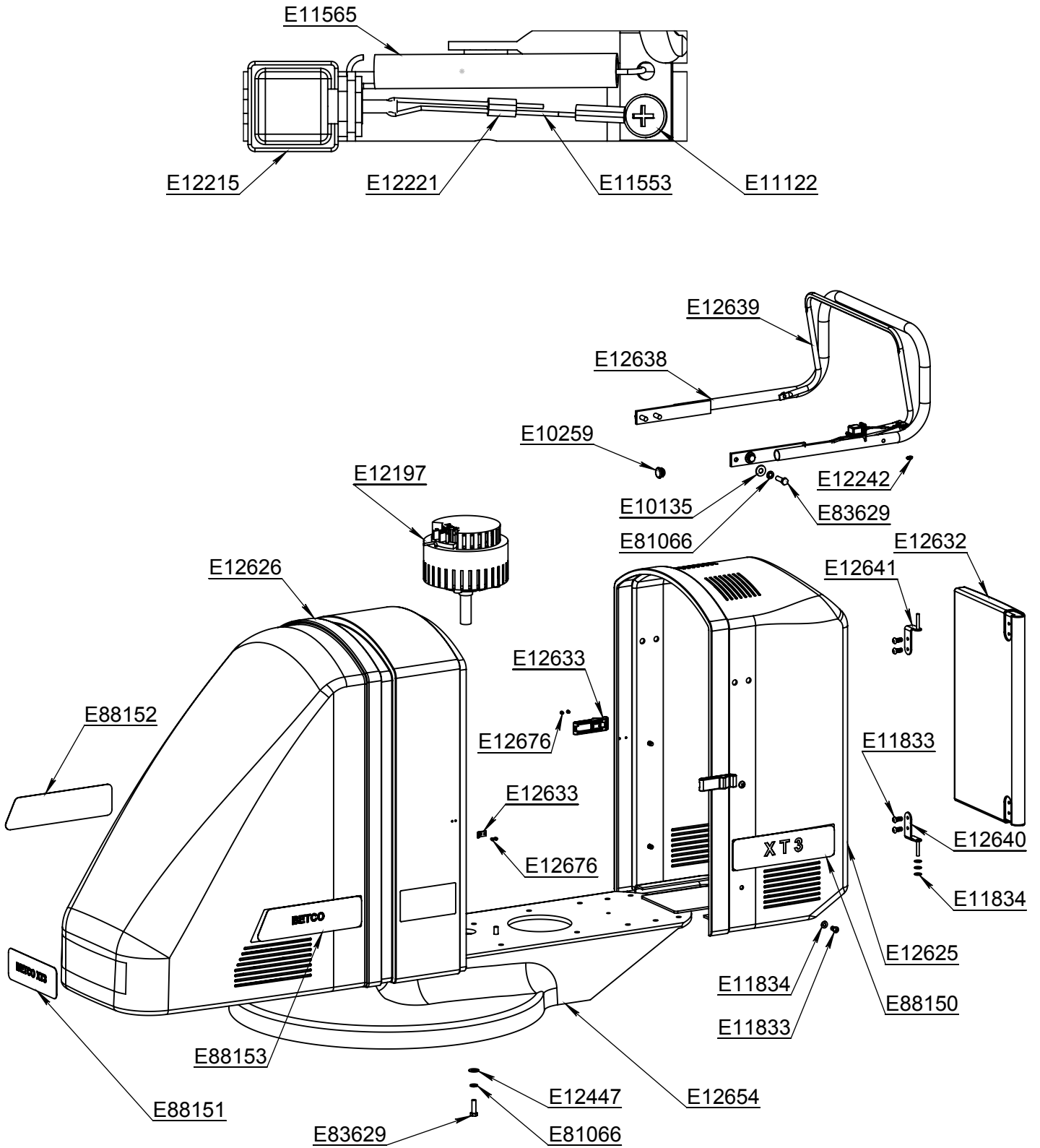

Covers & Handle Parts

PART NUMBER	Description	QTY.
E10135	Washer, 3/8" USS, Zinc	4
E10259	Plug, 1" Tube	2
E11122	Screw 1/4" x .500 Pan Head Phillips	1
E11407	Screw, 5/16"-18 x 3.250 Eyebolt with Nut, Zinc	1
E11553	Lanyard 3/64" x 6" XT Safety Switch	1
E11565	Spring, Extension 0.080 Wire, 1/2" OD x 3.850 L	1
E11833	Screw 1/4" - 20 x 0.750 Pan Head Phillips Black	8
E11834	Washer, SAE 1/4" Black	11
E12197	Motor, 36VDC, Brushless	1
E12215	Switch, Safety Shut Off	1
E12221	Crimp Sleeve, Cable, 3/8" L, Aluminum	1
E12242	Locknut, Flange 0.250 - 20	1
E12399	Dust Skirt, 21"	1
E12447	Washer, 7/16" SAE, Zinc	4
E12625	XT Gen 3 Cover	1
E12626	XT Gen 3 Cover	1
E12632	XT Gen 3 Cover Door	1
E12633	Latch Rubber Body	6
E12638	XT Gen 3 Handle Weldment	1
E12639	Shutoff Handle Weldment	1
E12640	Hinge Right	1
E12641	Hinge Left	1
E12654	Deck, 28 XT Gen 3	1
E12676	Rivet, 5/32"	12
E81066	Washer, 3/8" Split Lock, Zinc	8
E83629	Screw, 3/8"-16 x 1.250 Hex Head, Grade 5, Zinc	8
E88150	Decal, XT3 Rear	2
E88151	Decal, XT3 Front	1
E88152	Decal, XT3 Right	1
E88153	Decal, XT3 Left	1

Note: Not available for purchase assembled.

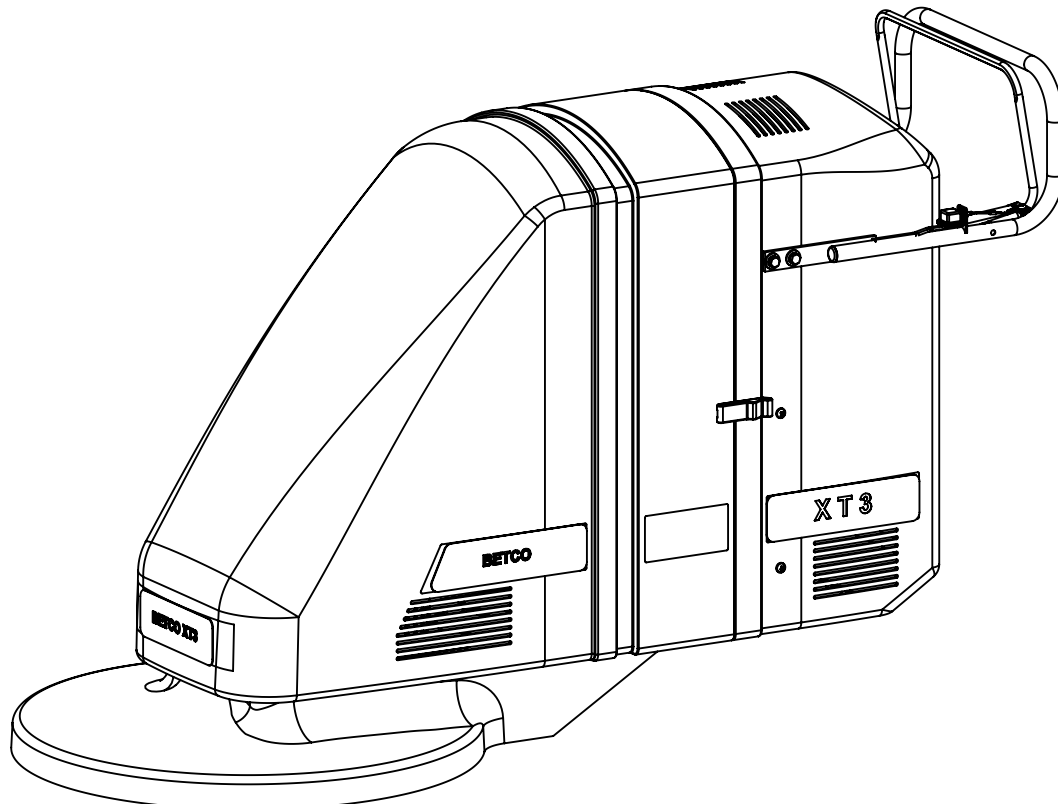

Frame & Deck Parts

E11293 - Dust Skirt 28"

E12584 is supplied with the machine. After removing the 5/16" eye bolt (E11407) insert it into the hole, use a hammer to seat.

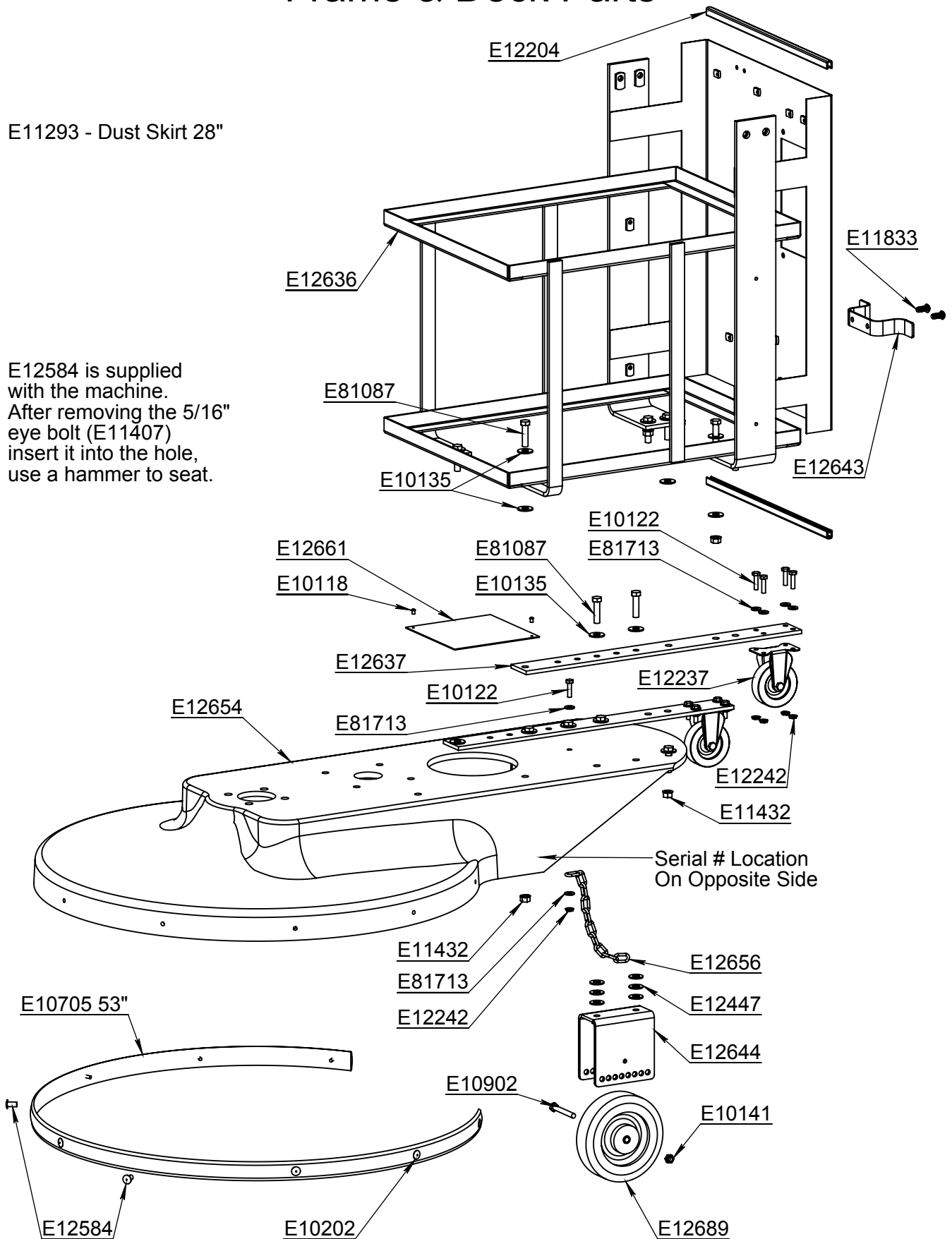

Frame & Deck Parts

PART NUMBER	Description	QTY.
E10118	Rivet AAP64	2
E10122	Screw, 1/4"-20 x 1.000 Hex Head, Grade 5, Zinc	9
E10135	Washer, 3/8" USS, Zinc	18
E10141	Nut, 5/16"-18, Slim, Nylon Lock, Grade 5, Zinc	2
E10202	Rivet, 3/16" OD x 0.700" L with 0.600" Head	7
E10705	Bumper, Red (21" Deck = 53", 24" Deck = 63", 28" Deck = 75")	1
E10902	Screw, 5/16"-18 x 2.500 Hex Head, Grade 5, Zinc	2
E11293	Dust Skirt 28"	
E11407	Screw, 5/16"-18 x 3.250 Eyebolt with Nut, Zinc	1
E11432	Locknut, Flange 0.375 - 16	12
E11833	Screw 1/4" - 20 x 0.750 Pan Head Phillips Black	2
E12204	Rubber Flange Extrusion	2
E12237	Caster, 3" 4 Bolt	2
E12242	Locknut, Flange 0.250 - 20	9
E12447	Washer, 7/16" SAE, Zinc	12
E12584	Rivet, 5/16" Drive (Hammer In)	2
E12636	XT3 Battery & Electrical Frame27"	1
E12637	Mounting Bracket, Handle to Deck XT27	2
E12643	Cord Wrap	1
E12644	Wheel Bracket XT	2
E12654	Deck, 28 XT Gen 3	1
E12656	Chain, Static Dispersion	1
E12661	Cover, XT3-27, Deck	1
E12689	Wheel, 6" with Sealed Ball Bearings, Non-Marking	2
E81087	Screw, 3/8"-16 x 1.500 Hex Head, Grade 5, Zinc	12
E81713	Washer, 1/4" SAE, Zinc	10

Note: Not available for purchase assembled.

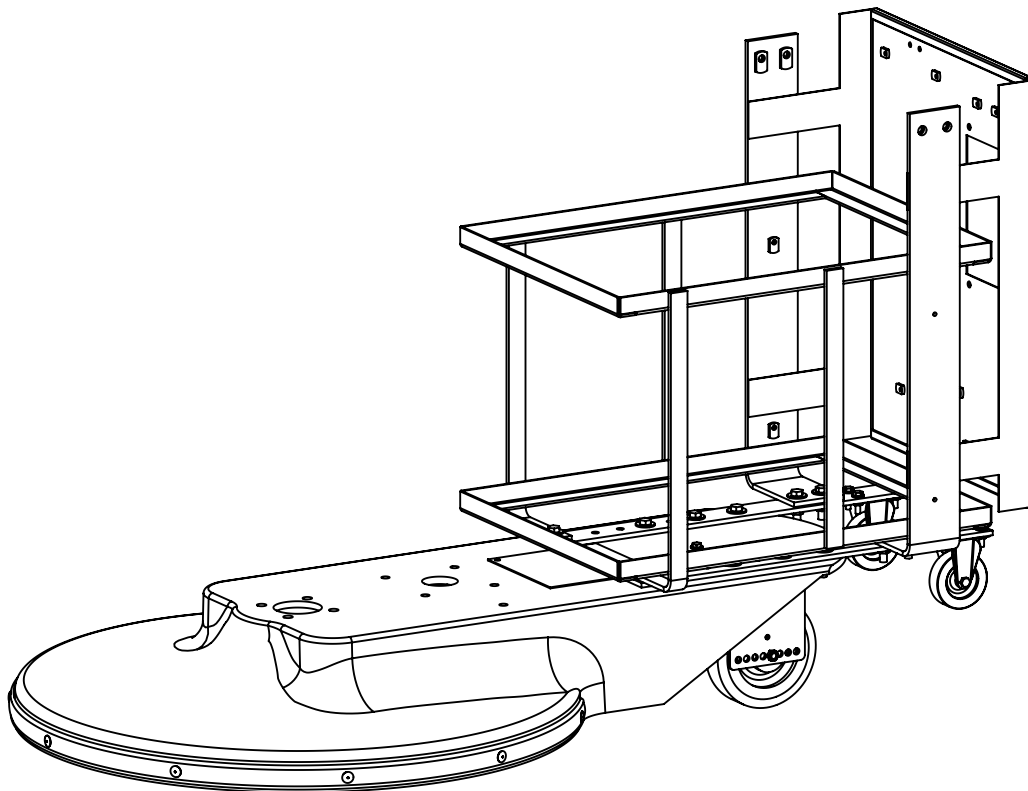

Belt Drive Parts

21" & 28" Deck Shimming:
Place 2 of the E83269 &
1 of the E12447 between
E12709 & aluminum deck
at this bolt location.

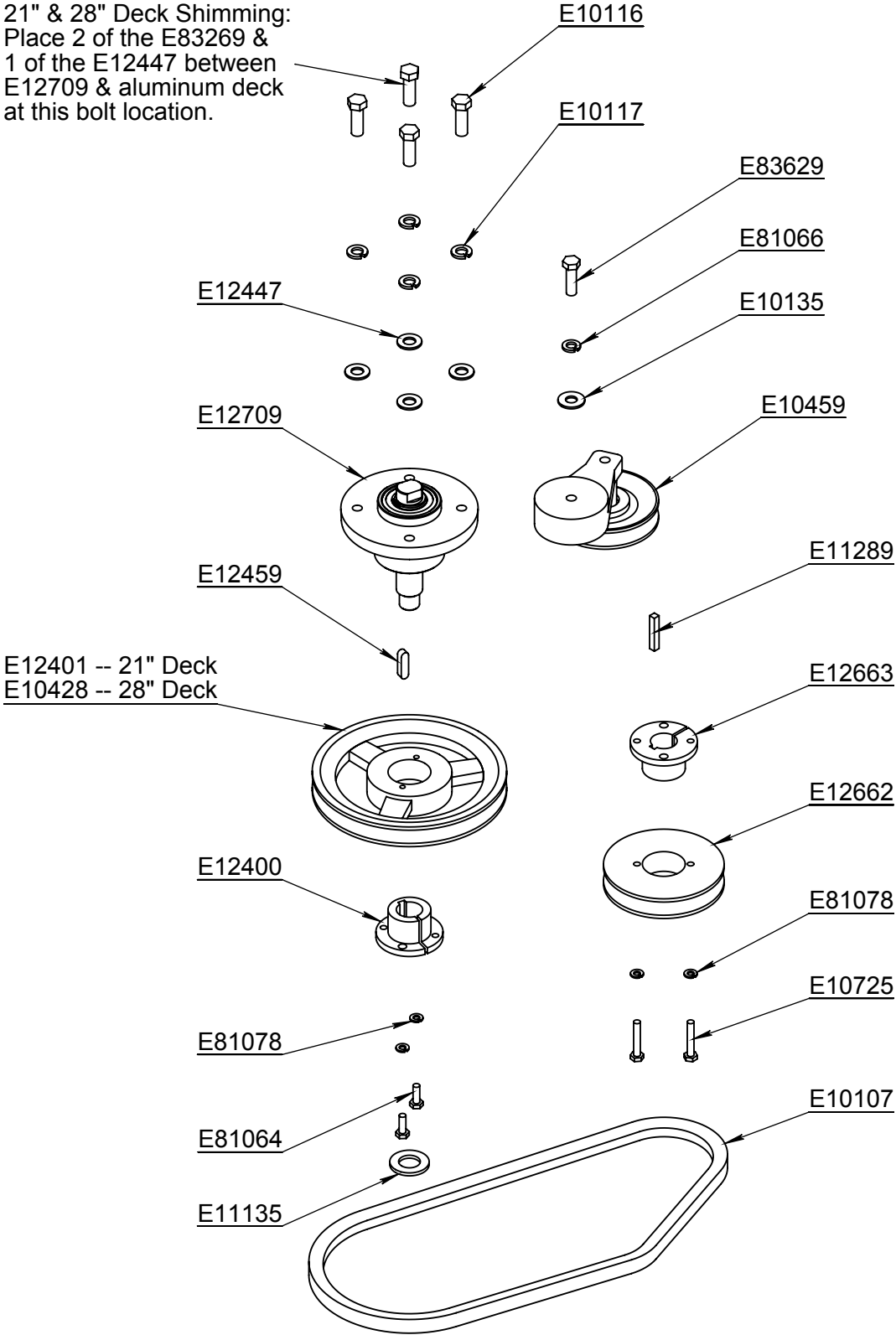

Belt Drive Parts

PART NUMBER	Description	QTY.
E10107	Belt, BX40	1
E10116	Screw, 7/16"-14 x 1.250 Hex Head, Grade 5, Zinc	4
E10117	Washer, 7/16" Split Lock, Zinc	4
E10135	Washer, 3/8" USS, Zinc	1
E10459	Belt Tensioner	1
E10725	Screw, 1/4"-20 x 1.500 Hex Head, Grade 5, Zinc	2
E11135	Washer, 3/4" SAE, Zinc	1
E11289	Key 1/4" x 1/4" x 1.500"	1
E12400	Bushing, QT 25mm Taper Lock	1
E12401	Pulley, BK75H - 7.25 OD	1
E12447	Washer, 7/16" SAE, Zinc	5
E12459	Key 8mm x 7mm x 30mm	1
E12662	Motor Pulley BK45QT	1
E12663	Bushing, QT 1.0" Taper Lock	1
E12709	Pad Driver Alum Bearing Assembly with Shaft	1
E81064	Screw, 1/4"-20 x 0.750 Hex Head, Grade 5, Zinc	2
E81066	Washer, 3/8" Split Lock, Zinc	1
E81078	Washer, 1/4" Split Lock, Zinc	4
E83269	Washer, 1/2" ID x 0.020" T, Spring	2
E83629	Screw, 3/8"-16 x 1.250 Hex Head, Grade 5, Zinc	1

Note: Not available for purchase assembled.

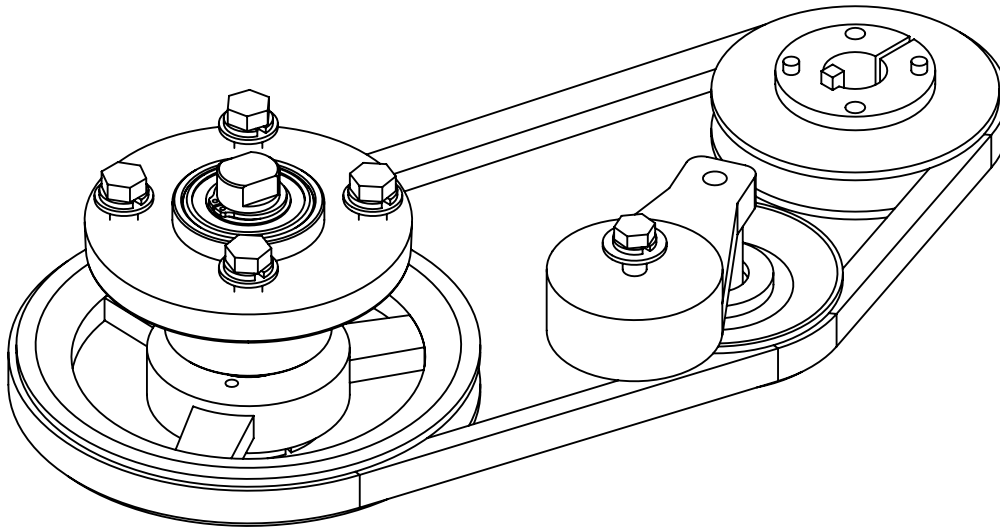

Pad Driver Parts

EP50028 -- 21" Pad Drive Assembly
EP50040 -- 27" Pad Drive Assembly

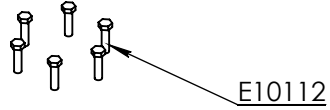

E10586

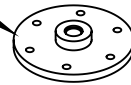

E10250 -- 21" Pad Driver
E10252 -- 27" Pad Driver

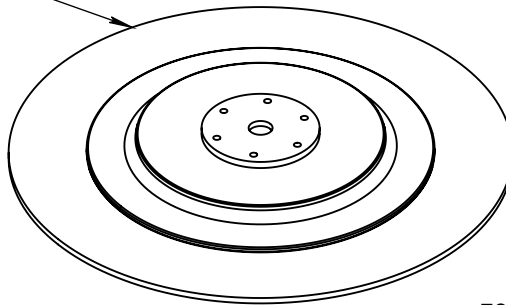

E81063



E12517
2 Piece Set

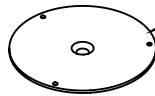

E10850



84621 -- 24" Pad
84627 -- 27" Pad

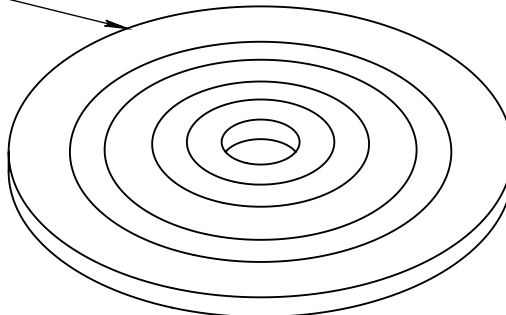

E12517
2 Piece Set

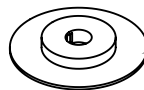

Pad Driver Parts

PART NUMBER	Description	QTY.
84621	Pad, 21" Hi-Shine Light Burnish Pad, 5/Case	1
84627	Pad, 27" Hi-Shine Light Burnish Pad, 5/Case	1
E10112	Screw, 5/16"-18 x 1.250 Hex Head Grade 5, Zinc	6
E10250	21" Pad Driver	1
E10252	27" Pad Driver	1
E10586	3/4" Pad Driver Shaft Coupling	1
E10850	Rivet, 3/16" OD x 15/16" L with 3/8" Head	3
E12444	Washer, 5/16" SAE, Zinc	6
E12517	Pad Lock, Center Lok II ® RH Set Black	2
E81063	Nut, 5/16"-18, Nylon Lock, Grade 5, Zinc	6
E81067	Washer, 5/16" Split Lock, Zinc	6
EP50028	Pad Drive Assembly 21" Without Pad	1
EP50040	Pad Drive Assembly 27" Without Pad	1

NOTE: Pad driver assembly comes without pad.

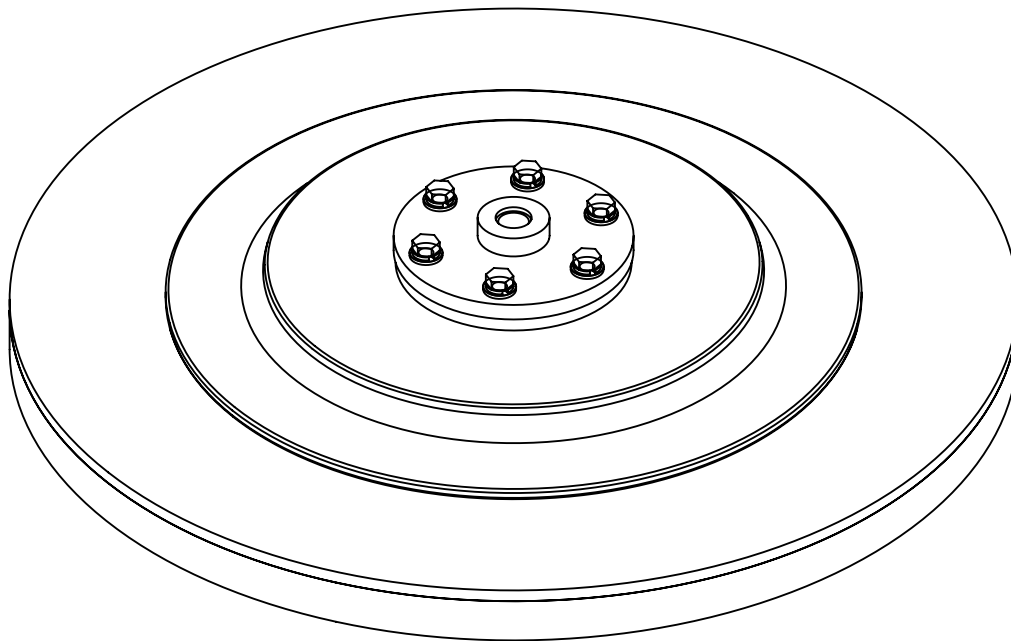

Battery & Electrical Parts

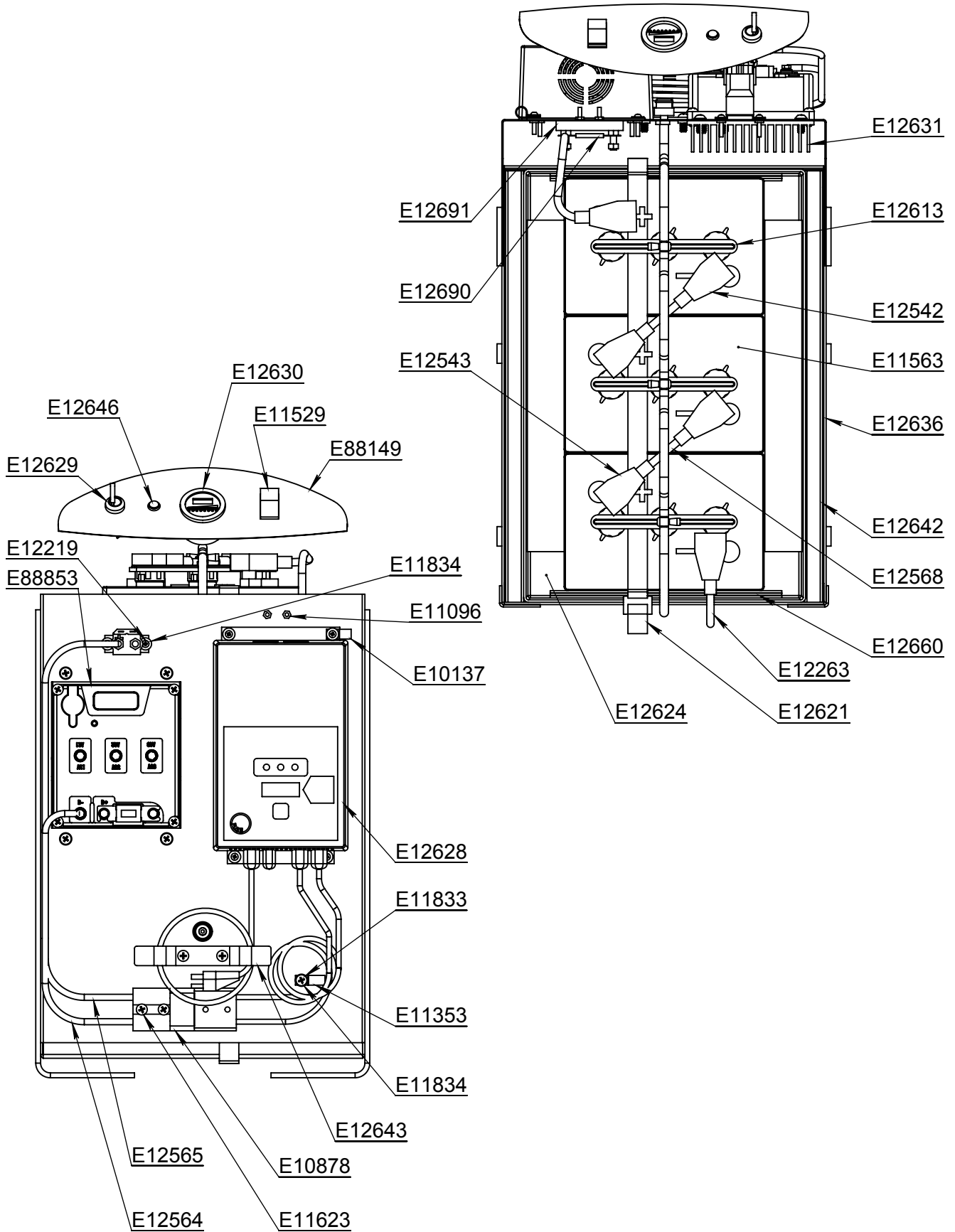

Battery & Electrical Parts

PART NUMBER	Description	QTY
E10137	Clamp, Tube 1/2" (COV-0909)	1
E10878	Anderson Plug, Grey	1
E11096	Nut, #10 - 32, Black	2
E11353	Tube Clamp 3/4" (COV-1309)	1
E11407	Screw, 5/16"-18 x 3.250 Eyebolt with Nut, Zinc	1
E11529	SWITCH, ROCKER	1
E11563	Battery, 6V, 225AH, Wet Cell	6
E11623	Screw 1/4" - 20 x 0.750 Pan Head Phillips Zinc	2
E11833	Screw 1/4" - 20 x 0.750 Pan Head Phillips Black	11
E11834	Washer, SAE 1/4" Black	11
E12219	Screw #10 - 24 x 1.000 Pan Head Phillips Black	8
E12242	Locknut, Flange 0.250 - 20	2
E12263	Cable, 4 AWG, Red, 20.00 L, 2 Lugs 0.313	1
E12542	Terminal Cover, Straight, Black	5
E12543	Terminal Cover, Straight, Red	6
E12564	Cable, 4 AWG, Red	1
E12565	Cable, 4 AWG, Black	1
E12568	Cable, 4 AWG, Black, 7.75 L, 2 Lugs 0.313	4
E12592	Solenoid	1
E12613	Battery Water Fill System	1
E12621	Battery Strap 72"	2
E12624	Battery Tray 3" height	2
E12625	XT Gen 3 Cover	1
E12628	Charger, On-Board	1
E12629	Switch, Keyed, SPE	1
E12630	Hour Meter, BDI	1
E12631	Heat Sink	1
E12636	Frame XT3-27	1
E12642	Battery Tray Bottom Plate	2
E12643	Cord Wrap	1
E12646	E12646 Lamp, 36VDC, LED	1
E12660	Shim, Plastic, 12" x 1.50" x 0.125"	12
E12674	Spacer, Battery, 1.900 OD Scd 80	4
E12690	Fuse, 200 AMP	1
E12691	Fuse Block	1
E88149	Decal, XT3 Dashboard	1
E88853	XT3 Gen 4 Controller	1

Note: Not available for purchase assembled.

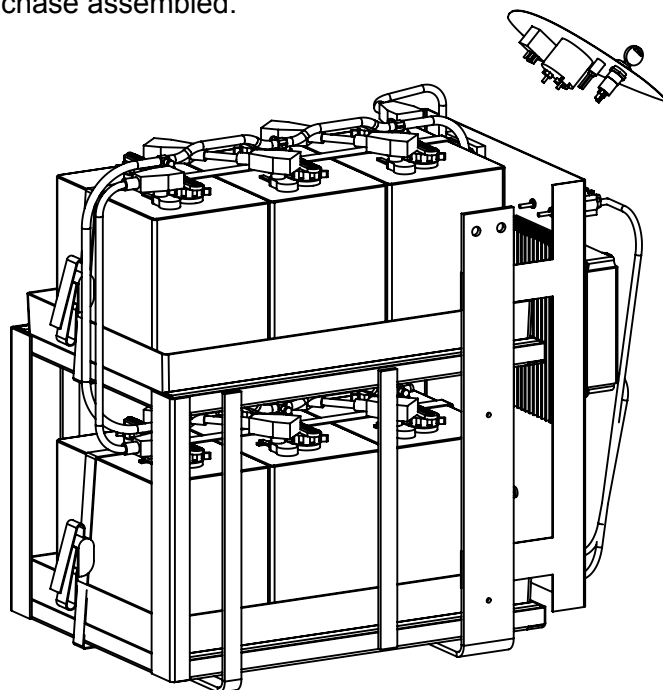

XT3-27 BATTERY CONNECTIONS

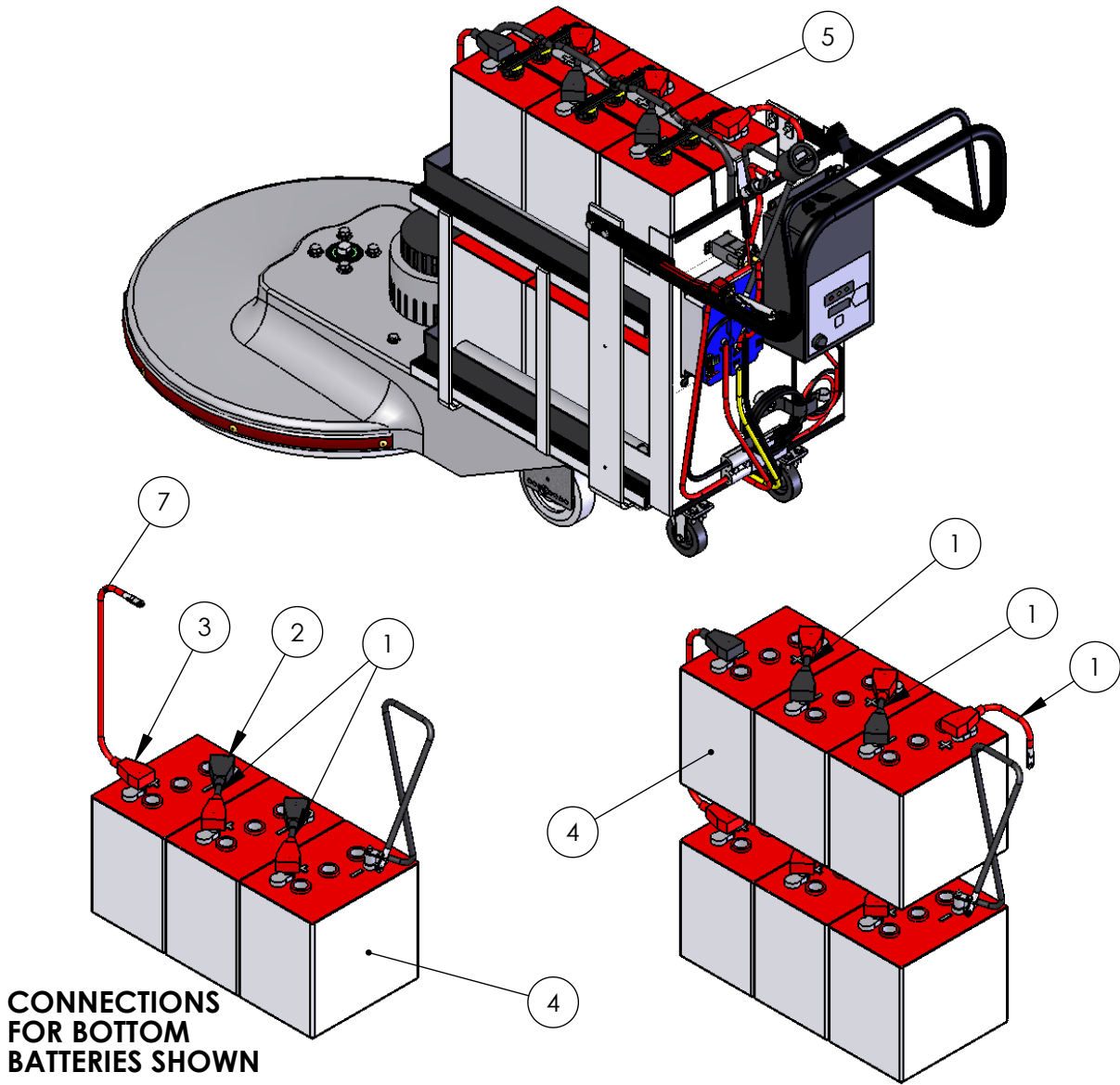

**RED TERMINAL PROTECTORS ARE ON POSITIVE TERMINALS
BLACK TERMINAL PROTECTORS ARE ON NEGATIVE TERMINALS**

ITEM NO.	PART NO.	QTY.	DESCRIPTION
1	E012568	5	WIRE, BATTERY CABLE, 4 GA, RED, 7.75"
2	E012542	6	TERMINAL PROTECTOR, STRAIGHT, BLACK
3	E012543	6	TERMINAL PROTECTOR, STRAIGHT, RED
4	E011563	6	BATTERY, 6 VOLT, 225 AMP HOUR
5	E012613	1	WATERING SYSTEM, FOR NEW STYLE 6 VOLT BATTERY
6	E012562	1	WIRE, BATTERY CABLE, 4 GA, BLACK, 36"
7	E012263	1	WIRE, BATTERY CABLE, 4 GA, 20"

XT3-27 WATERING WITH STANDARD BATTERIES

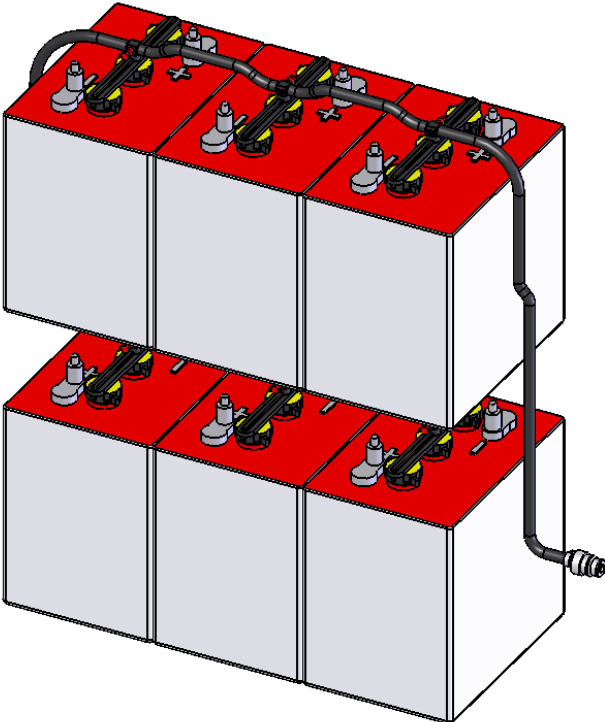

PRO-FILL WATERING SYSTEM - PART # E012613

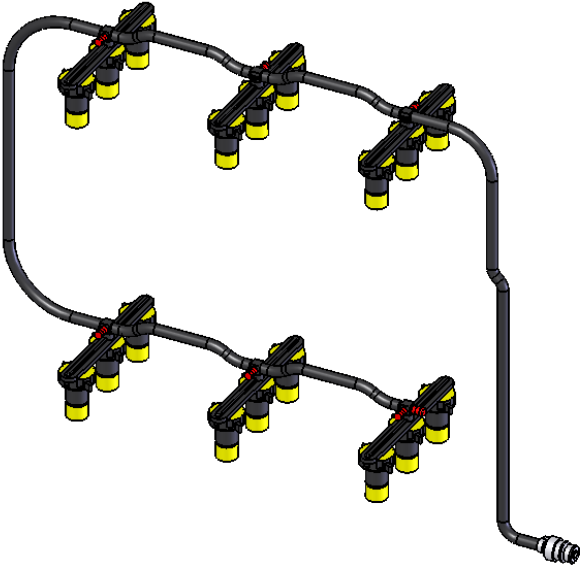

Electrical Layout

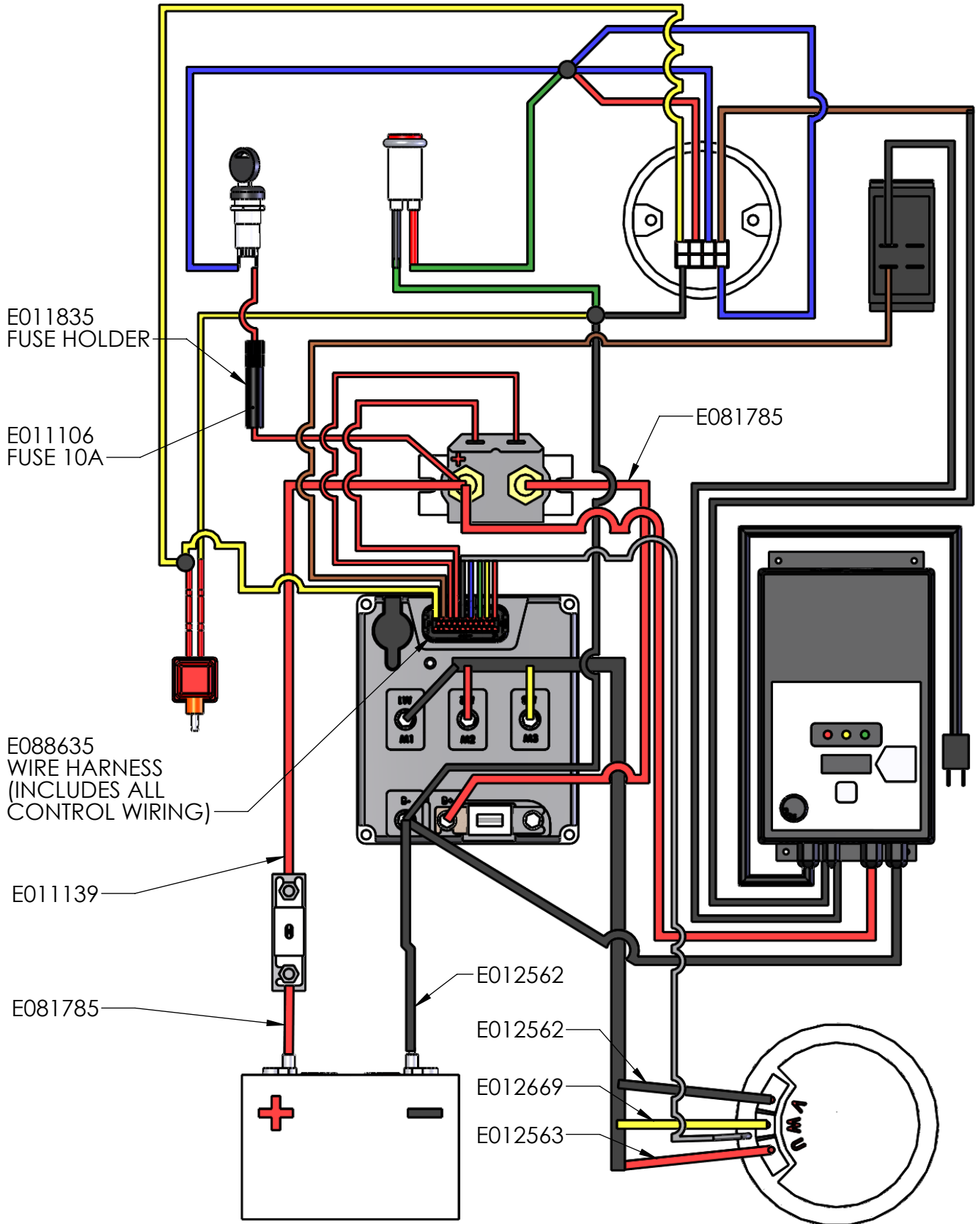

TROUBLE-SHOOTING

PROBLEM	CAUSE	POSSIBLE SOLUTION
No sign of power. No on lamp, no BDI readout.	(a) Bad connection (b) Bad connection to BDI (c) On-board charger is plugged in (d) Batteries dead (e) Charger plugged into outlet	(a) Check all connections. (b) Make sure connector is fully pushed into BDI. (c) Disconnect charger from wall outlet. (d) Recharge or replace batteries as needed. (e) Unplug charger from 110v outlet. Charger has an "inhibit" circuit that prevents machine from running if charger is plugged in.
Powers on with key switch, but solenoid does not "click" with rocker switch.	Bad connection	Check all connections.
Powers on, solenoid "clicks", but does not run	(a) Safety run switch problem. Not pulling plunger enough to activate. (b) Safety run switch wire connectors may be loose	(a) Cable may have slipped and sleeve needs to be re-crimped or replaced. (b) Push in connectors
Pad "bogs down"	Too much pad pressure	Decrease pressure using directions on "Balancing Instructions" page
Machine will not set upright with cover on	Too little pad pressure	Increase pad pressure using directions on "Balancing Instructions" page
Low runtime	(a) Improper charge (b) Old batteries or defective cell in battery (c) Too much pad pressure. (d) BDI set to too high a voltage	(a) Make sure that batteries get a full charge after each use. (b) Replace batteries. Best to replace as a set. (c) Balance machine. See "Balancing Instructions" page. (d) See BDI instruction page on how to set to a value of 4 for optimal run time and battery life
Machine vibrates	(a) Pad not centered (b) Pad is torn or worn excessively	(a) Remove pad and re-center the pad (b) Replace pad
Noise coming from underside of deck	Belt is loose and causing belt tensioner to "chatter".	Tighten belt. See page with "Belt tightening instructions".
Machine hard to push	(a) Worn pad (b) Worn wheel bearings (c) Pad out of alignment	(a) Replace pad. (b) Replace bearings or replace wheels. (c) See solution to next problem "Machine pulls left".
Machine pulls left	(a) Worn pad (b) Wrong pad (c) Right side of pad needs a little more contact than the left so "pad assist" can help pull machine forward .	(a) Replace pad (b) Replace pad with pad approved use with XT burnisher. (c) Add a small shim (.010 thick) between bearing housing and deck on the right side. This will "push" right side down toward floor. (If there are too many shims, then left side of pad will not contact properly).
Uneven floor buffing (right side of pad polishes and left side does not)	Right side of pad contacting too much, therefore left side is not contacting enough.	The reverse of the previous procedure. Remove one of the small shims (.010 thick) between bearing housing and deck on the right side



Betco Warranty Express Program™ Revised November 1, 2006

10 Year Coverage

Subject to the conditions stated below, Betco Corporation warrants parts and labor on rotationally molded polyethylene tanks/housings and injection molded vacuum head assemblies to be free from defects in materials and workmanship for a period of ten years to the original purchaser.

3 Year Coverage

Subject to the conditions stated below, Betco Corporation warrants parts and labor on all other Betco components to be free from defects in materials and workmanship for a period of three years to the original purchaser.

1 Year Coverage

Subject to the conditions stated below, Betco Corporation offers a limited warranty on parts and labor on the following equipment, parts and accessories to be free from defects in material and workmanship for a period of one year to the original purchaser.

- DM Series Vacuums:
#85506-00, #85507-00
- Bac Pac Lite Vacuum:
#85903-00
- FiberPRO® Floor Dryer:
#85507-00
- WORKMAN™ Series Vacuums:
#85024-00, #85025-00,
#85026-00, #85027-00
- CV100T Vacuum:
#85023-00
- All Tools and Accessories
- All Battery Chargers
- All Batteries are pro-rated for 1 year.

Allowable Travel Time Warranty Reimbursement:

Eligible equipment: All battery and propane powered equipment products.

Warranty period: 90 days from date of sale to the original purchaser. A maximum 60 mile round trip at 44 cents per mile will be allowed for warranty consideration.

Propane Machine Warranty:

Honda engines are warranted by Honda for a period of 2 years against manufacturer defect. Kawasaki engines are warranted by Kawasaki for a period of 2 years against manufacturer defect. All other components (except wear items)* are warranted by Betco Corporation for a period of 3 years.

***Wear items exempt from warranty consideration include but may not be limited to: power cords, transport wheels, vacuum bags, belts, squeegee blades, pad drivers, clutch plates, handle grips, filters, screens, throttle cables, brushes and carbon brushes.**

Subject to the conditions and exceptions stated in this warranty, Betco warrants the Betco products to be free from defects in material and workmanship, under normal use and service, for the periods listed under the warranty policy to the original purchaser. At any time during the warranty period, Betco will furnish replacement parts for the Betco products to the original purchaser. Such parts will be furnished and charged including transportation costs, to the original owner through any Betco authorized Service Distributor. If the original part is returned within the warranty policy period from date of delivery for inspection by Betco and is found to be defective, the owner will be credited for the cost of replacement parts plus shipping and handling. Replacement parts that have become defective through wear or abuse are not included in this warranty.

This warranty does not apply to damage or defect caused by accident, misuse, negligence, fire or to any Betco product which has been serviced or repaired by other than an authorized Betco Service Distributor or Betco factory personnel. This warranty is void if products are used for any purpose other than that which was intended. There are no other warranties expressed or implied. In no event shall Betco be liable for incidental or consequential damages or any damage to person or property. (Please note some states do not allow the exclusion or limitations for incidental and consequential damages.)