



E88398-00



LIL BERTHA™

24" Extreme Strip and Scrub Machine



(SERIAL NUMBERS 7999 AND LESS)

Operator and Parts Manual

400 Van Camp • Bowling Green, Ohio 43402
Customer Service: 888-GO-BETCO • Fax: 800-445-5056 • Technical Service: 877-856-5954 • www.betco.com

TABLE OF CONTENTS

CARBON MONOXIDE WARNING	3
SAFETY	4
TANK USE AND STORAGE	5
STARTING AND STOPPING THE HONDA ENGINE.....	5
OPERATOR PREPARATION	6
MAJOR ASSEMBLIES	7
HANDLE BAR	8 - 9
LOWER HANDLE SUPPORT.....	10 - 13
REGULATOR ASSEMBLY	14 - 15
12V STARTER SWITCH.....	14 - 15
KAWASAKI ENGINE ASSEMBLY.....	16 - 17
DECK ASSEMBLY.....	18 - 19
MAIN DRIVE SYSTEM.....	20 - 21
PIVOT BRACKET ASSEMBLY	22 - 25
BRUSH PLATE ASSEMBLY.....	26 - 27
ENGINE MAINTENANCE.....	28
ELECTRICAL SCHEMATIC	29
MAIN DRIVE BELT	30
BRUSH DRIVE PLATE AND BELT	31
BRUSH CHANGE.....	32
TROUBLESHOOTING	33
EMISSIONS WARRANTY	34 - 35
WARRANTY.....	36



WARNING - CARBON MONOXIDE LETHAL EXHAUST GAS - MUST READ THIS! -



Never Run The Engine In A Closed Building Or Confined Area

Exhaust gases contain poisonous carbon monoxide.
Carbon monoxide is odorless, colorless, and can cause death if inhaled.

Carbon Monoxide Poisoning Symptoms

Train your employees to know the warning signs of carbon monoxide poisoning.

Mild carbon monoxide poisoning may cause any of the following:
Headache, drowsiness, faintness, poor coordination, nausea, and vomiting.
Turn the engine off and immediately get to fresh air if you have any of these symptoms.

Do not run the machine until it is given an emissions test and repairs made by an authorized distributor.

- Local emissions testing is available at a fork-lift service department.

Moderate or severe carbon monoxide poisoning causes confusion, unconsciousness, chest pain, shortness of breath, and coma. Thus, most victims are not able to move themselves and must be rescued. Severe poisoning is often fatal.

Carbon monoxide is dangerous because a person may not recognize drowsiness as a symptom of poisoning. Consequently, someone with mild poisoning can go to sleep and continue to breathe the carbon monoxide until severe poisoning or death occurs. Some people with long-standing, mild carbon monoxide poisoning caused by furnaces or heaters may mistake their symptoms for other conditions, such as the flu or other viral infections.

Carbon Monoxide Detectors

CO detectors are a must for safe operation of your equipment. Various types are available. A “CO” carbon monoxide detector detects carbon monoxide before it reaches dangerous levels. Detectors are a must for those who run propane powered equipment. The CO Detector is for everyone’s protection against Carbon Monoxide Poisoning.

- Carbon Monoxide Detector - Passive
 - Effective for 30 days after package has been opened.
 - Write the date opened on the detector.
 - Mount with self-adhesive strip on the machine handle.
 - Train machine operator to check detector regularly.
 - If the **orange disk changes to gray or black** - your Carbon Monoxide Levels are at a Dangerous Level.
 - If the **orange disk changes to gray or black** you must **turn your buffer off immediately** and return it to your nearest authorized distributor for an emissions test.
 - **Do Not Restart** the machine until the emissions have been checked and corrected.
 - This is for your protection as well as your customers. CO detectors are a must for safe operation and maximum efficiency of your equipment.
 - For replacement CO detectors, contact your distributor. Ask for the **carbon monoxide detector, part# E012426.**
- Carbon Monoxide Detector - battery operated with alarm
 - Available from various sources

SAFETY

Important Safety Information

All LPG (Liquid Propane Gas) powered engines, including this engine, produce Carbon Monoxide (CO). It is a **Lethal Poison** that is colorless, odorless, tasteless, and non-irritating gas. You must read “Danger: Lethal Exhaust Gas” information below.

Keep hands, feet, and loose clothing away from all moving parts while the machine is in operation. The exhaust system gets very hot so keep hands, clothing and any items that can burn away from the engine, engine manifold, and muffler.

These machines are tough and durable, however do not abuse the machine. With proper care and maintenance this unit will give you years of trouble free operation.

Carbon Monoxide Safety Information

Engine exhaust gases contain poisonous carbon monoxide. Carbon monoxide is odorless, colorless, tasteless, and can cause death if inhaled. Failure to provide proper venting of CO, failure to properly maintain the engine, or failure to properly train personnel of the dangers and warning signs of carbon monoxide exposure may result in **Serious Injury Or Death** to the operator and others in the area.

- Any equipment with the potential to produce carbon monoxide presents a significant hazard when used indoors. They must be used with great caution. Opening a door or window, or running an exhaust fan will not necessarily supply adequate ventilation. Avoid inhaling exhaust fumes and never run the engine in a closed building or confined area without proper ventilation.
- Do not allow engine to run unattended.
- If you have any indication that the engine is not running properly, immediately shut the machine off and have it checked over and repaired by qualified maintenance personnel.
- Workers should be trained to recognize the hazards of carbon monoxide and the early symptoms of carbon monoxide poisoning.
- A carbon monoxide detector and alarm should be available to alert workers of emissions.
- Have a carbon monoxide detector attached to machine handle or have machine operator wear a carbon monoxide detector. (See carbon monoxide detector page).
- Use only as described in this manual.
- Use only manufacturer’s recommended components.
- Maintenance and repairs must be done by qualified personnel.
- Only trained operators should be allowed to operate propane powered floor machines.
- If the machine is not working properly, have it serviced by an authorized service center.
- Install fuel cylinder in a well ventilated place.
- Be aware of possible leaks of propane gas if odor is present.
- If the machine is stored inside a building, remove the fuel cylinder and store properly outside.
- Secure fuel cylinders when being transported.
- If tank is left attached to the machine then valve should be OFF.
- Never store fuel cylinders in a vehicle, building, or area where they may be exposed to high temperature.
- Do not operate the machine with any openings blocked.
- Keep openings free of debris that may reduce airflow.
- Remove fuel cylinder and disconnect battery before servicing.

TANK USE AND STORAGE

Propane Tank Use

We use the Worthington gas cylinders designed for vapor withdrawal. The fuel lock offs, regulators, and engines are also designed for vapor withdrawal.

- We recommend that you use the OPD (Overflow Protection Device) vapor withdrawal type cylinder. These style tanks have a triangle shaped valve handle.
- Do not overfill - the best gauge is a scale - never allow tank to weigh over **36 pounds** for an aluminum tank and **43 pounds** for a steel tank.
- Connect fuel cylinder to machine in a well ventilated place.
- Be aware of possible leaks of propane gas if odor is present.
- Use propane tanks designed for vertical use only.
- New tanks must be purged of air at first filling.

Propane Tank Storage

- Store tanks outside in a well-ventilated area.
- Never store fuel cylinders in a vehicle, building, or area where they may be exposed to high temperature.
- If the machine is stored inside a building, remove the fuel cylinder and store properly outside.
- Secure fuel cylinders when being transported.
- If tank is left attached to the machine then valve should be OFF.
- Store tanks in the upright position (valves up).
- Be aware of possible leaks of propane gas if odor is present.

STARTING AND STOPPING THE KAWASAKI ENGINE

Starting The Kawasaki Engine

The Kawasaki engine is equipped with a 12 volt starter and a key switch start.

1. Place propane tank into handle assembly and close propane tank strap clamp to secure tank.
2. Attach propane hose coupling and fully tighten.
3. Start the Extreme Strip machine with the brushes in the running position, flat on the floor.
4. Open propane tank valve (turn counterclockwise) and check for any leaks.
5. Turn the ignition - Start switch to the 'start' position and hold it there until the engine starts. Do not crank for more than 20 seconds at a time and wait at least one minute between tries when cranking. See the troubleshooting guide if the engine does not start after several tries.
6. After engine starts, set the throttle so that the centrifugal clutch will not engage until the engine has warmed up. Do not operate the machine until the engine has warmed up sufficiently (3 to 5 minutes).
7. Check for frost on the regulator and fuel line. Frost will indicate that the machine is drawing liquid propane from an overfilled or incorrect tank.

Stopping The Kawasaki Engine

1. Turn propane tank valve to the closed position (turn clockwise) and allow the engine to continue running until it runs out of fuel. This can be done with the centrifugal engaged or not engaged.
2. Turn key to the off position.

**In an emergency, immediately turn the key to the 'off' position.
Backfiring may occur when using this method.**

OPERATOR PREPARATION

Before Starting the Machine

Read the Owner's Manual and the Engine Operation Manual.

Your machine is shipped ready for operation; however there is no fuel in the tank. When having the tank filled, you must make sure the tank is never over-filled.

- The best way to do this is to tell the filling station to weigh the tank full. On an aluminum tank, it should weigh no more than **36 pounds** and on a steel tank no more than **43 pounds**. (See more information at "Tank Storage and Maintenance" page.)

Adjust the handle for comfortable operation. Remove detent pins from handle and adjust to the hole alignment that gives the most comfortable height. Replace detent pins. Tighten nuts and bolts if needed.

Check Oil Level: Starting the engine without the proper amount of oil will cause severe engine damage. Always keep the engine oil level between the full and add marks on the dipstick. Do not loosen oil fill cap or remove dipstick while engine is running.

- Park your machine on a level surface.
- Turn the oil fill cap counter clockwise and then lift from the fill tube.
- Wipe the dip stick clean and push it back into the oil fill tube until the cap seats and then withdraw it to check: the oil level. (Do not screw cap on to check oil). Add if necessary. If the oil level is low, add API Class SM oil having a SAE viscosity grade appropriate for the expected temperatures as indicated in the Operators Manual (Usually a HD30 or 10W30).
- Important Note: **Do Not Overfill**
- Replace oil cap.

Inspect fuel hoses and fittings for wear and leaks. Have all worn hoses and leaks repaired before operating.

Look and listen for exhaust leaks. Have all leaks repaired before operating.

Check the carburetor filter and air filter for debris. Clean and replace if necessary.

Connect fuel hose to tank by screwing the hose fitting to tank. You must tighten all the way down to make fuel connection. Turn tank knob slowly until you hear the flow of fuel into fuel system.

MAJOR ASSEMBLIES

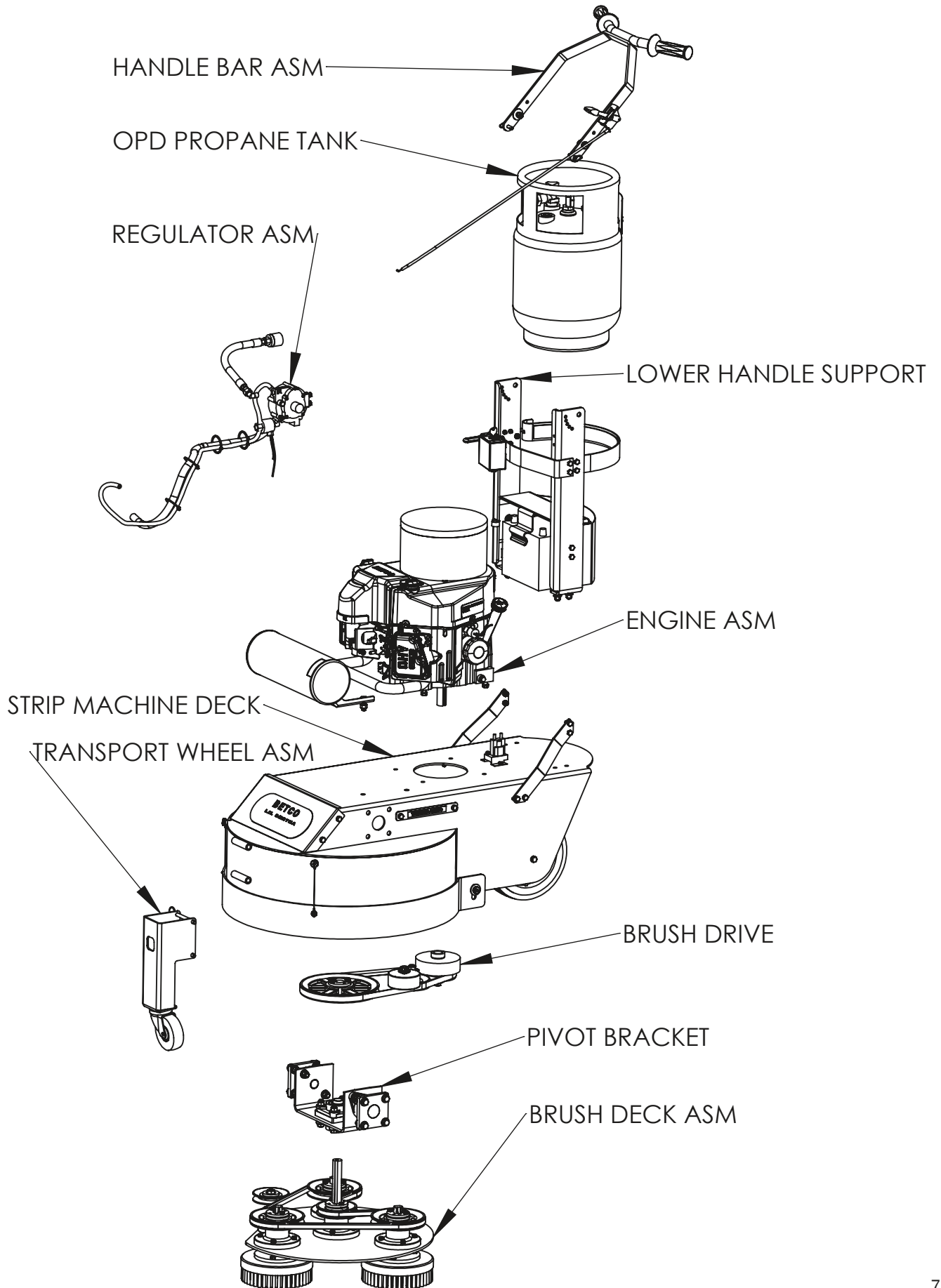

HANDLE BAR

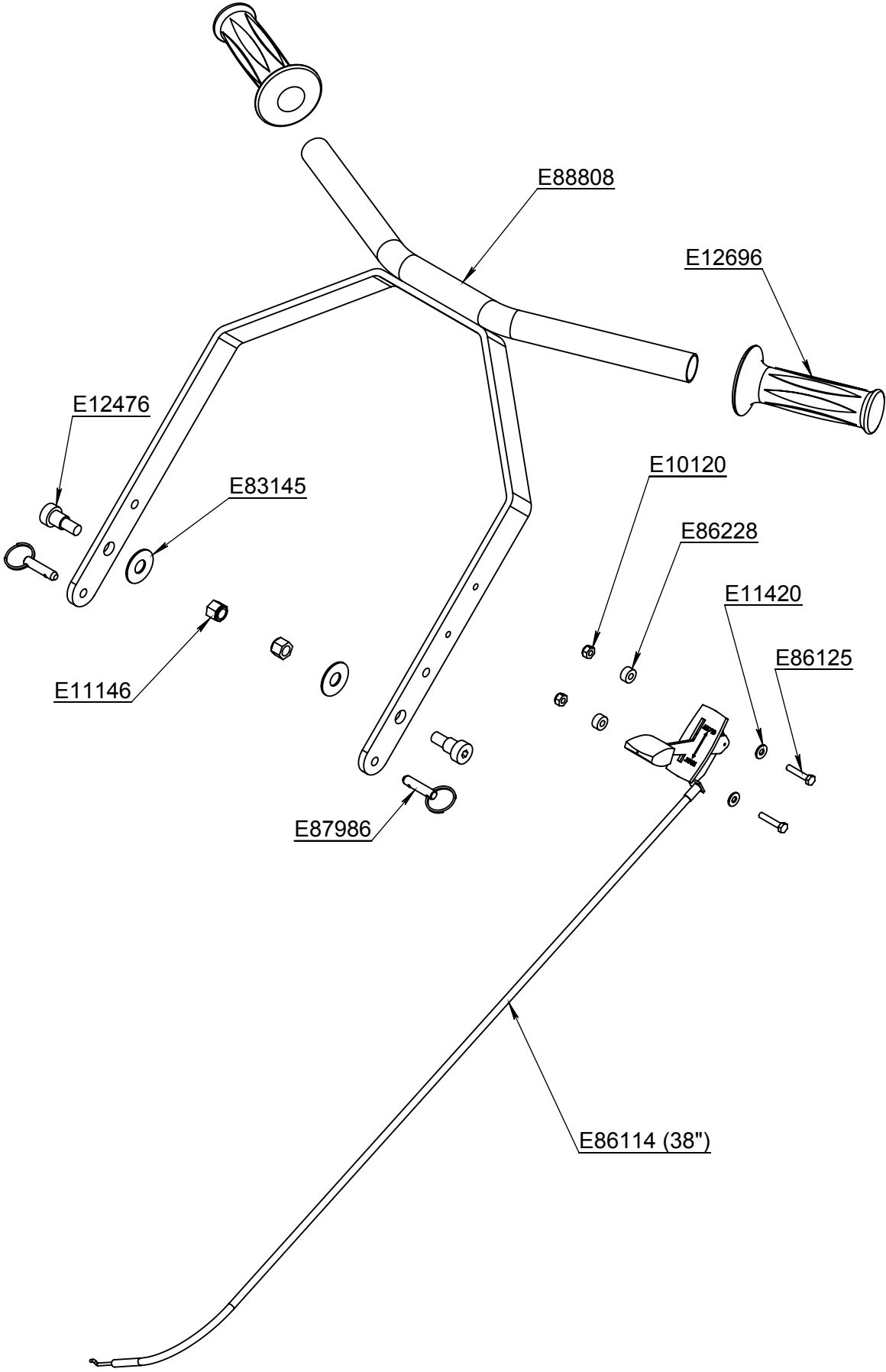

PART NUMBER	Description	QTY.
E10120	Nut, #10-32, Nylon Lock, Grade 5, Zinc	2
E11146	Nut, 3/8"-16, Nylon Lock, Grade 5, Zinc	2
E11420	Washer, #10 SAE, Zinc	2
E12476	Screw, Shoulder 1/2" x 1/2" Socket Head	2
E12696	Hand Grip	2
E83145	Washer, Nylon 1/2" ID X 1.25" OD	2
E86114	Kawasaki Throttle Cable 38" L	1
E86125	Screw, #10-32 x 1.000 Hex Head, Zinc	2
E86228	Spacer, #10 ID x 1/2" OD x 1/4" Long, Black Nylon	2
E87986	Pin, 5/16" x 3/4" Detent with Ring	2
E88808	Handle Bar Weldment	1

Note: Not available for purchase assembled.

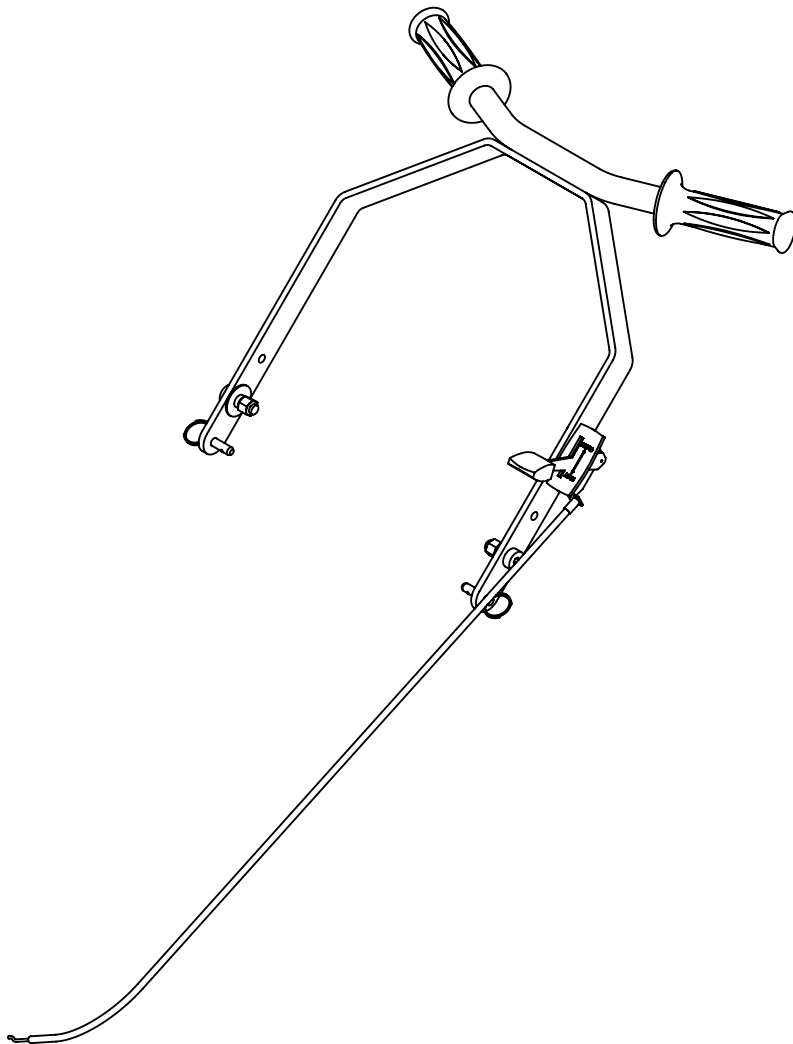

LOWER HANDLE SUPPORT

(For Serial Numbers Before 6999)

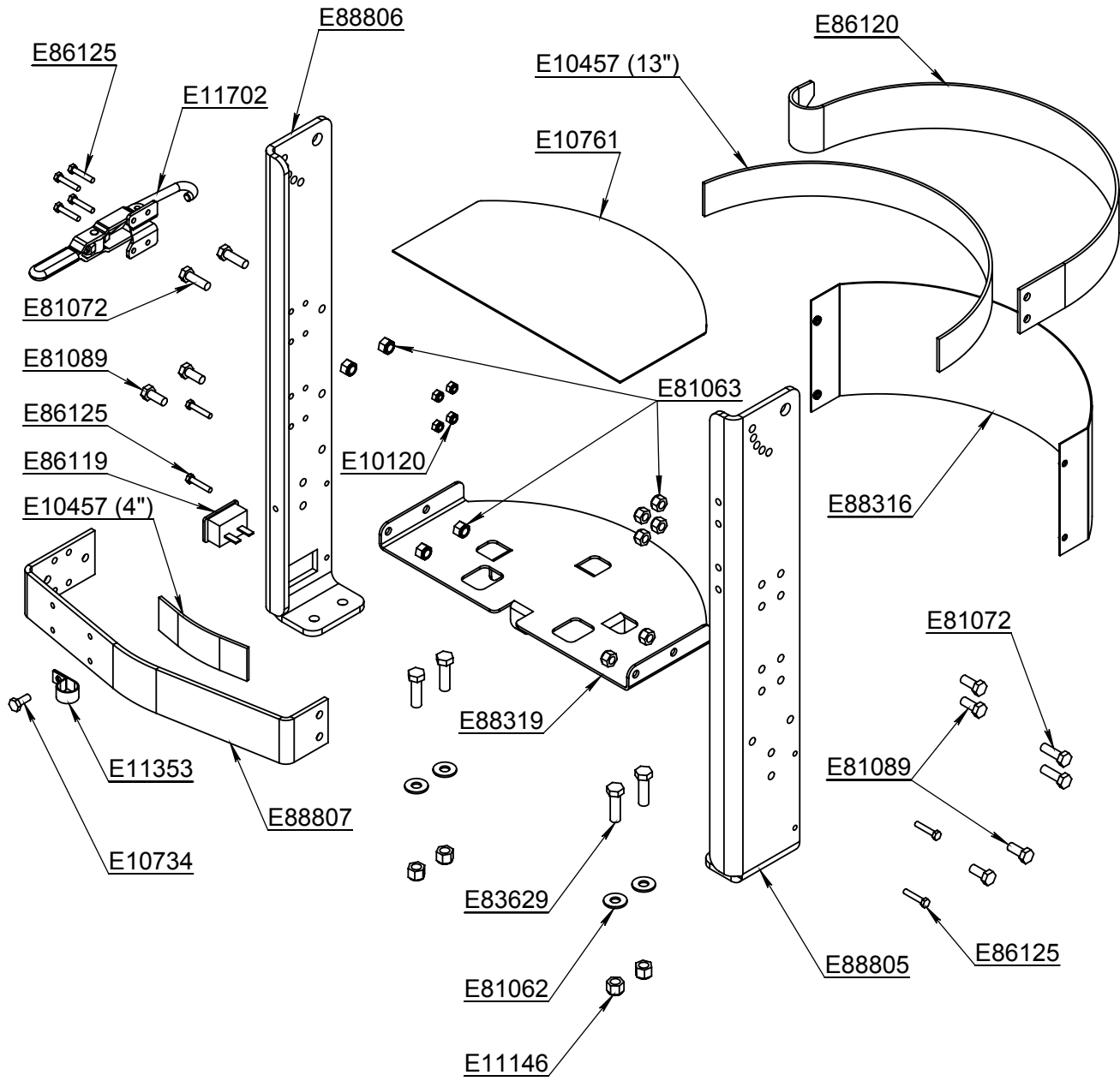

PART NUMBER	Description	QTY.
E10120	Nut, #10-32, Nylon Lock, Grade 5, Zinc	4
E10457	Felt, 1.500 W x 0.125 Thick, Adhesive Back	2
E10734	Screw, 1/4"-20 x 0.625 Hex Head, Grade 5, Zinc	1
E10761	Rubber Propane Tank Shelf Pad	1
E11146	Nut, 3/8"-16, Nylon Lock, Grade 5, Zinc	4
E11353	Tube Clamp 3/4" (COV-1309)	1
E11702	Propane Tank Strap Latch	1
E81062	Washer, 5/16" USS, Zinc	4
E81063	Nut, 5/16"-18, Nylon Lock, Grade 5, Zinc	10
E81072	Screw, 5/16"-18 x 1.000 Hex Head, Grade 5, Zinc	4
E81089	Screw, 5/16"-18 x 0.750 Hex Head, Grade 5, Zinc	6
E83629	Screw, 3/8"-16 x 1.250 Hex Head, Grade 5, Zinc	4
E86119	Hour Meter, SenDEC 5-80V	1
E86120	Propane Tank Strap Back	1
E86125	Screw, #10-32 x 1.000 Hex Head, Zinc	8
E88316	Battery Cover	1
E88319	Propane Tank Shelf	1
E88805	Lower Handle Leg Left	1
E88806	Lower Handle Leg Right	1
E88807	Propane Tank Strap Front	1

Note: Not available for purchase assembled.

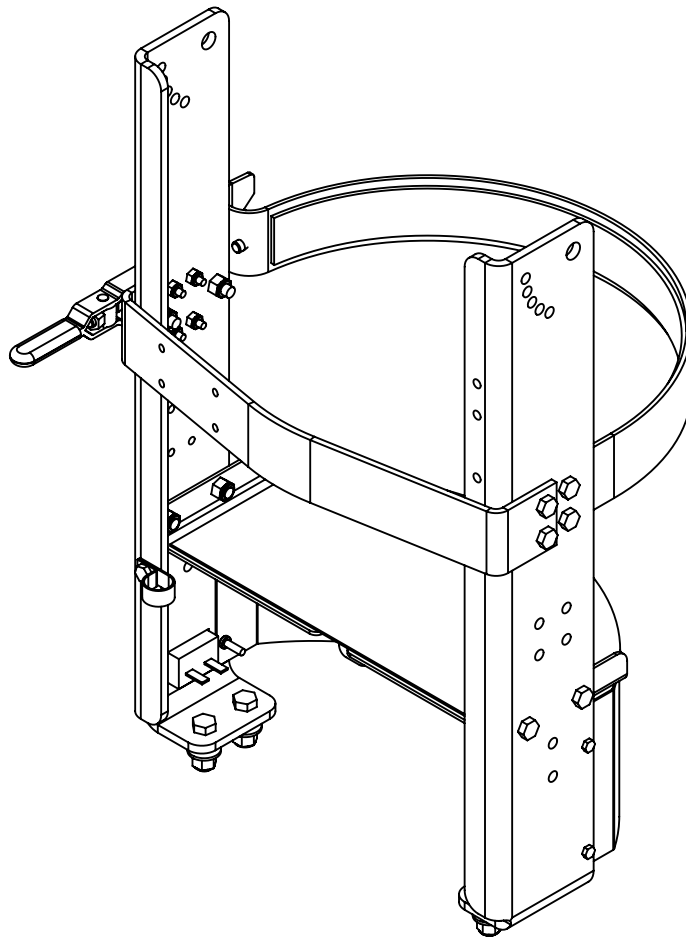

LOWER HANDLE SUPPORT

(For Serial Numbers 7000 and Greater)

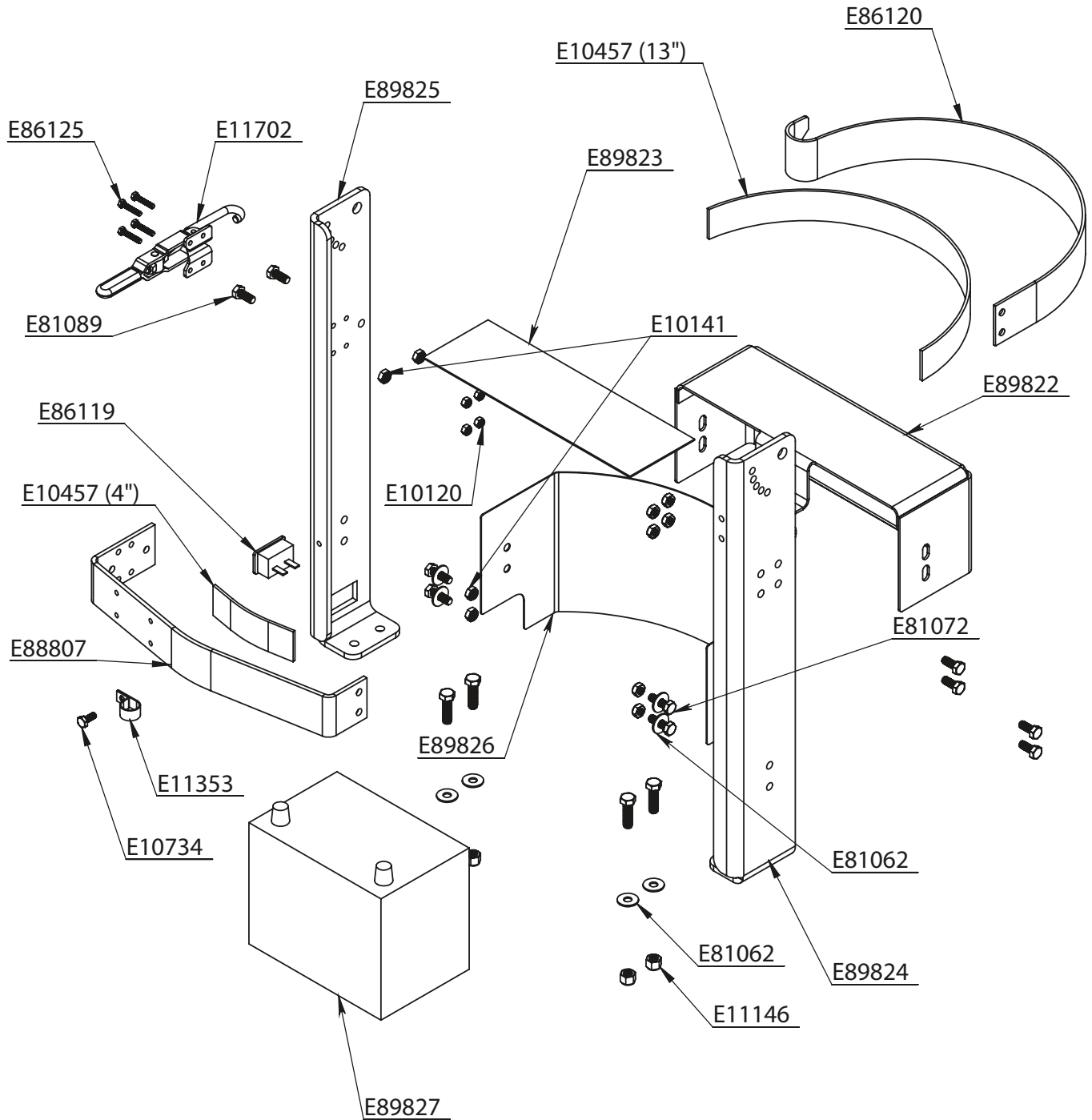

PART NUMBER	DESCRIPTION	QUANTITY
E10120	NYLOC HEX NUT 10-32	4
E10141	NYLOC HEX JAM NUT 0.3125-18 ZINC	10
E10457	FELT, 1.500 W x 0.125 THK, ADHESIVE BACKED	2
E10734	HEX HEAD BOLT 1/4-20 x 5/8 LG	1
E11146	NYLOC HEX NUT 3/8-16, ZINC	4
E11353	TUBE CLAMP 3/4"	1
E11702	PROPANE TANK STRAP CLAMP	1
E81062	FLAT WASHER 5/16 USS, ZINC	8
E81072	HEX HEAD SCREW 5/16-18 x 1.00 LG	4
E81089	HEX HEAD BOLT 5/16-18 x 3/4 LG	6
E83629	HEX HEAD BOLT 3/8-16 x 1-1/4 LG	4
E86119	HOUR METER	1
E86120	PROPANE TANK STRAP BACK	1
E86125	HEX HEAD BOLT, 10-32 x 1.00 LG	4
E88807	PROPANE TANK STRAP FRONT	1
E89822	BATTERY CLAMP AND PROPANE SUPPORT	1
E89823	RUBBER PROPANE TANK SHELF PAD	1
E89824	LOWER HANDLE LEG LEFT	1
E89825	LOWER HANDLE LEG RIGHT	1
E89826	BATTERY COVER	1
E89827	BATTERY U1 12 VOLT	1

Note: Not available for purchase assembled.

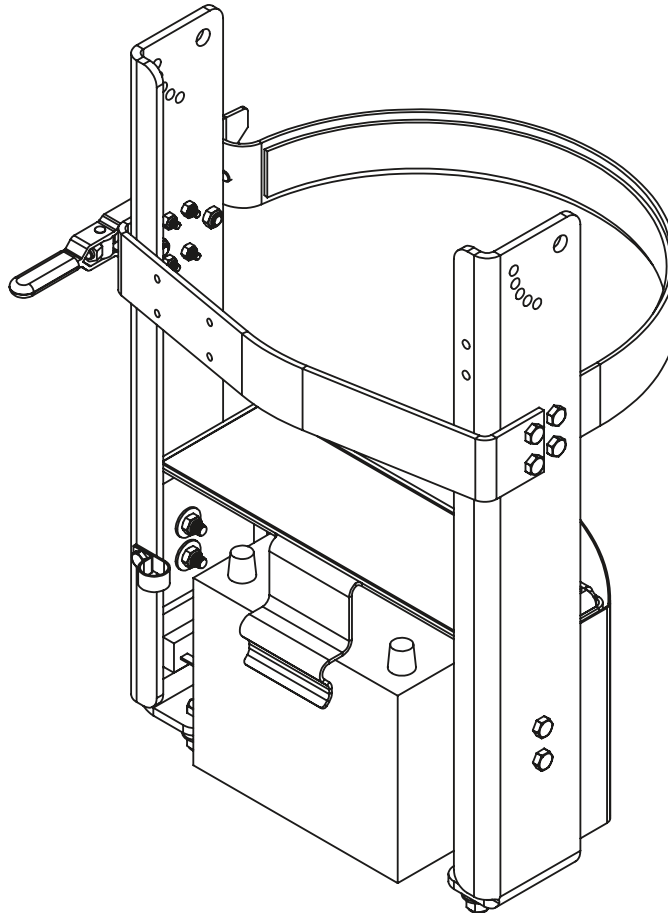

REGULATOR ASSEMBLY

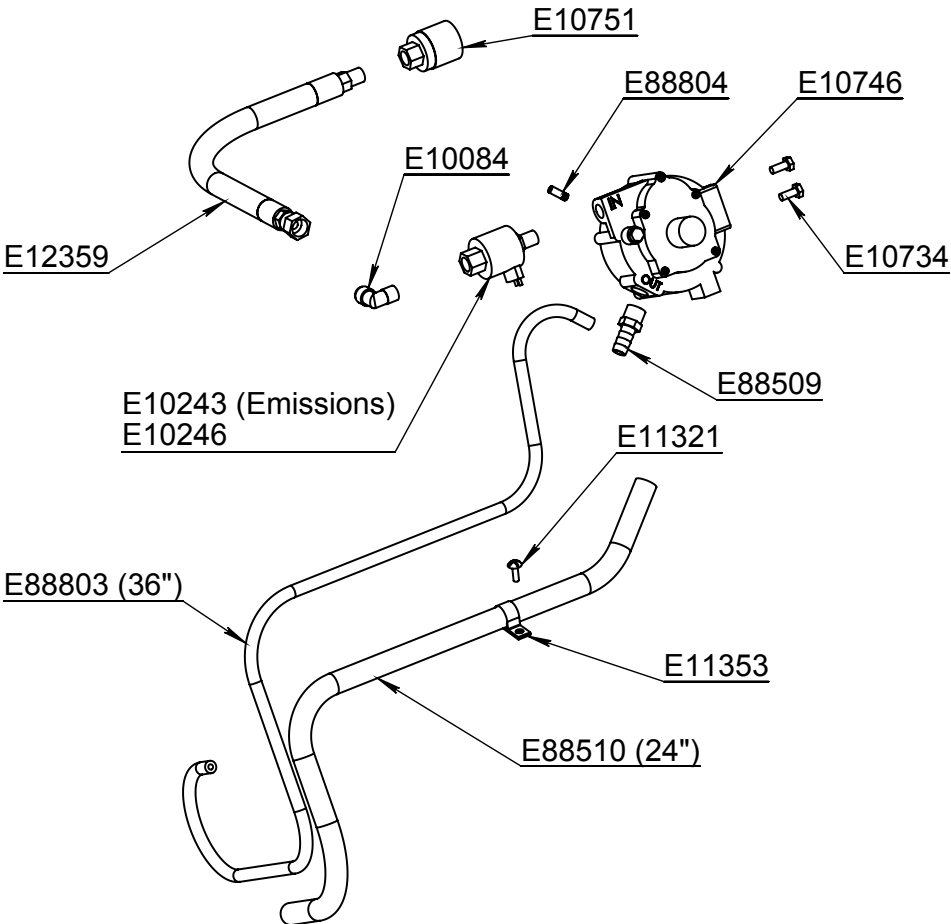

12V STARTER SWITCH

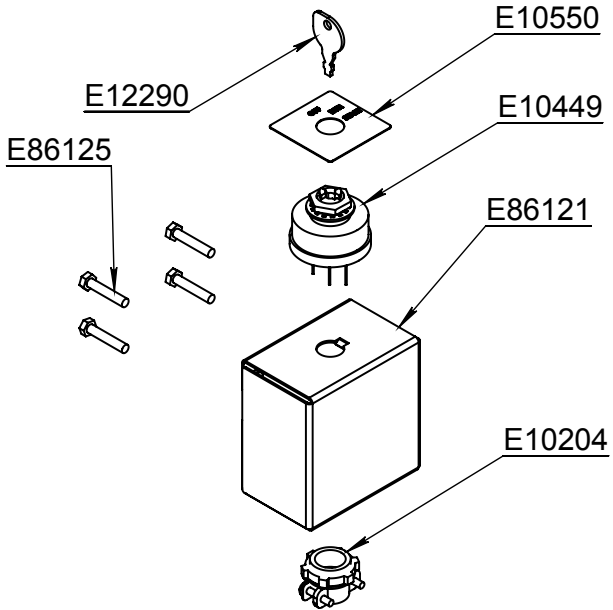

PART NUMBER	Description	QTY.
E10084	Fitting, 3/8 MJIC x 3/8 MNPT, 90 Elbow, Brass	1
E10243	In Line Fuel Shut Off Valve Model 152 (With Emissions)	1
E10246	In Line Fuel Shut Off Valve Model 151	1
E10734	Screw, 1/4"-20 x 0.625 Hex Head, Grade 5, Zinc	2
E10746	Fuel Regulator Model 60E	1
E10751	Propane Tank Coupling 7141F	1
E11321	Screw #10 x 5/8" Sheet Metal, Pan Head, Phillips, Black	1
E11353	Tube Clamp 3/4" (COV-1309)	1
E12359	Propane Tank Hose 1/4" MNPT - 3/8" MJIC 16.50" L	1
E88509	Fitting, Hose Barb 3/8" MNPT x 1/2" Barb, Brass	1
E88510	1/2" ID Braided Gasoline Fuel Hose (24")	1
E88803	Hose, 3/16" ID Vacuum	1
E88804	Fitting, 1/4"-28 Thread, 1/4" OD, 0.046 Wall, 0.700 L, Brass	1

Note: Not available for purchase assembled.

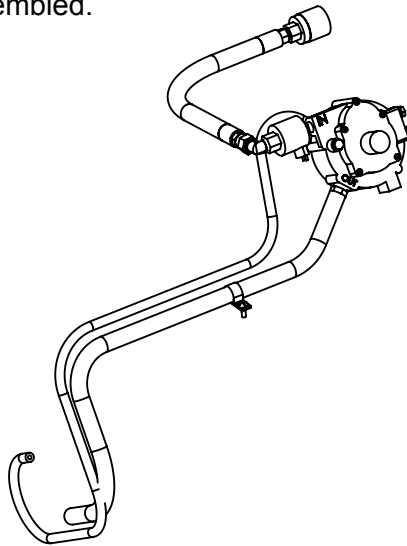

PART NUMBER	Description	QTY.
E10204	Wire Clamp, 3/8" Romex Connector	1
E10449	5 Wire Keyed Ignition Switch	1
E10550	Decal, OFF/ON/START	1
E12290	Ignition Switch Key	1
E86121	Key Switch Box	1
E86125	Screw, #10-32 x 1.000 Hex Head, Zinc	4

Note: Not available for purchase assembled.

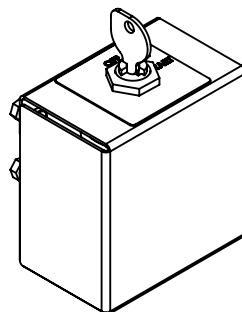

KAWASAKI ENGINE ASSEMBLY

- E10242 - Emission Kit (E10248 & E10249)
- E10245 - Bung Plug M18 x 1.5mm
- E10337 - Valve Oil Seal
- E10544 - Decal, Clutch
- E12426 - CO Detection Badge
- E12525 - Drive Shaft Oil Seal
- E85461 - Oil Drain Hose ASM
- E88326 - Spark Plug
- E88327 - Ignition Coil ASM
- E88328 - Air Intake Manifold
- E88468 - Head Gasket
- E88469 - Cylinder 1 Head ASM
- E88470 - Cylinder 2 Head ASM
- E88471 - Valve Cover Gasket
- E88472 - Intake Valve
- E88473 - Exhaust Valve
- E88476 - Dipstick Tube O-Ring
- E88511 - Voltage Regulator
- EP50146 - LP Ready Kawasaki Engine ASM With Emission Kit (E10242)
- EP50147 - LP Ready Kawasaki Engine ASM

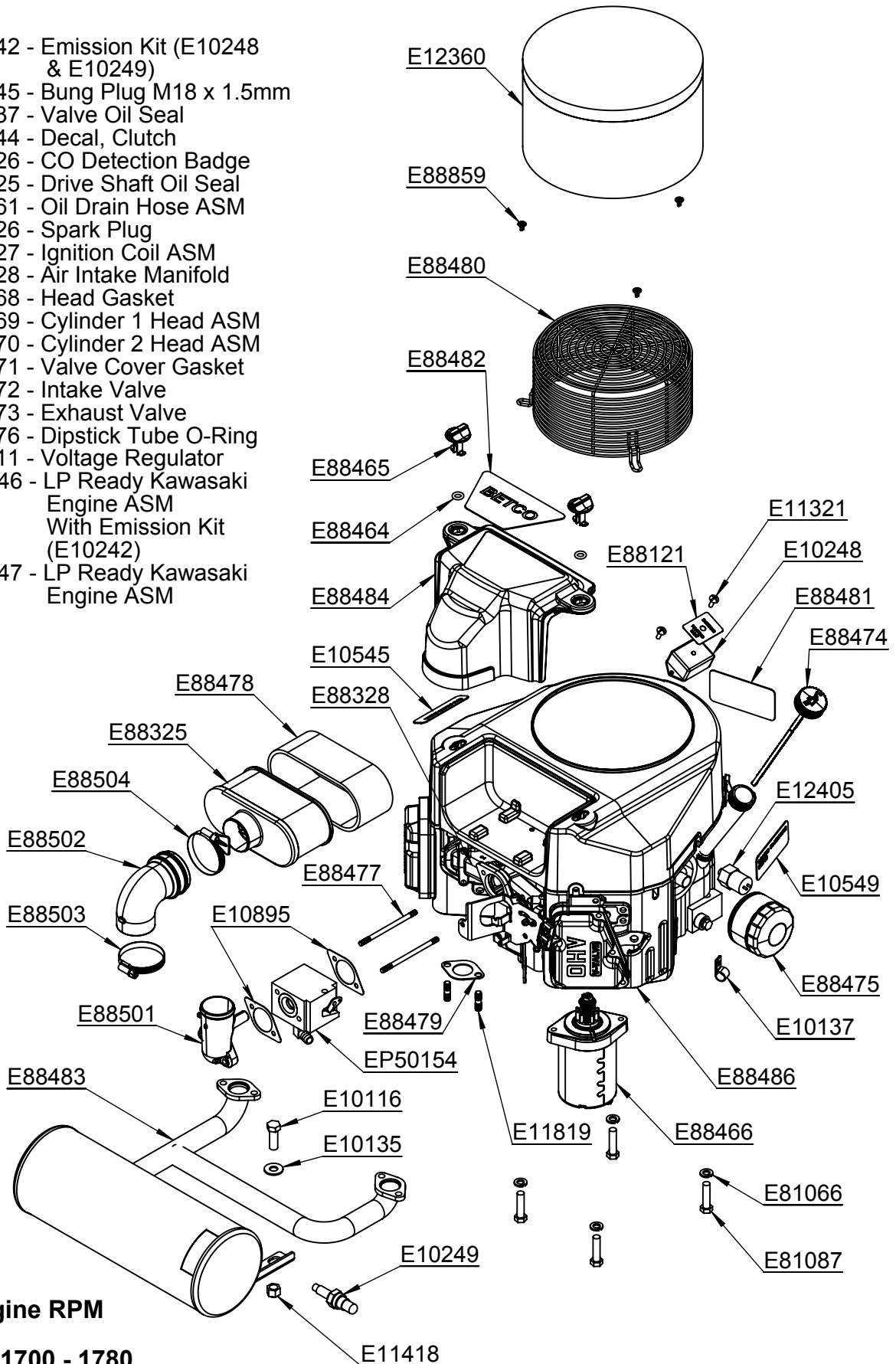

Engine RPM

Idle = 1700 - 1780
Full Throttle = 3600

PART NUMBER	Description	QTY.
E10116	Screw, 7/16"-14 x 1.250 Hex Head, Grade 5, Zinc	1
E10135	Washer, 3/8" USS, Zinc	1
E10137	Clamp, Tube 1/2" (COV-0909)	1
E10242	Emissions Kit (E10248, E10249)	1
E10245	Bung Plug M18 x 1.5mm	1
E10248	O2 Sensor Electrical Control Box	1
E10249	O2 Sensor	1
E10337	Valve Oil Seal	4
E10544	Decal, Clutch	1
E10545	Decal, Read Oners Manual	1
E10549	Decal, Caution Oil Pressure Switch	1
E10895	Gasket, Carburetor to Air-Fuel Hub	2
E11321	Screw #10 x 5/8" Sheet Metal, Pan Head, Phillips, Black	2
E11418	Nut, 7/16"-14, Nylon Lock, Grade 5, Zinc	1
E11819	Stud, 8mm x 18mm L	4
E12360	Cooling Air Intake Filter	1
E12405	Oil Pressure Switch	1
E12426	CO Detector Badge	1
E12525	Drive Shaft Oil Seal	1
E81066	Washer, 3/8" Split Lock, Zinc	4
E81087	Screw, 3/8"-16 x 1.500 Hex Head, Grade 5, Zinc	4
E85461	Oil Drain Hose Accessory	1
E88121	Decal, Emissions Warning Light	1
E88325	Air Intake Filter Paper	1
E88326	Spark Plug	2
E88327	Ignition Coil ASM	2
E88328	Air/Fuel Intake Manifold	1
E88464	O-Ring 12.5mm ID x 3.4mm T	2
E88465	Air Filter Thumb Nut	2
E88466	12V Starter	1
E88468	Head Gasket	2
E88469	Cylinder 1 Head ASM	1
E88470	Cylinder 2 Head ASM	1
E88471	Valve Cover Gasket	2
E88472	Intake Valve	2
E88473	Exhaust Valve	2
E88474	Oil Dipstick	1
E88475	Oil Filter	1
E88476	O-Ring	1
E88477	Stud, 6mm x 95mm L	2
E88478	Air Intake Filter Foam	1
E88479	Muffler Gasket	2
E88480	Cooling Air Intake Guard	1
E88481	Decal, Emissions	1
E88482	Decal, Air Filter Cover	1
E88483	Muffler, Catalytic, & Manifold Kawasaki FS481V	1
E88484	Air Filter Cover	1
E88486	Kawasaki Engine Gasoline Ready 16HP	1
E88501	Carburetor Intake Neck	1
E88502	Air Intake Elbow	1
E88503	Air Intake Elbow to Neck Clamp	1
E88504	Air Intake Elbow to Filter Clamp	1
E88511	Voltage Regulator	1
E88859	Rivet, Push, Cooling Air Intake Guard, FS481V ASM	3
EP50146	LP Ready Kawasaki Engine Assembly With Emission Kit (E10242)	1
EP50147	LP Ready Kawasaki Engine Assembly	1
EP50154	Carburetor, LP Gas FS481V	1

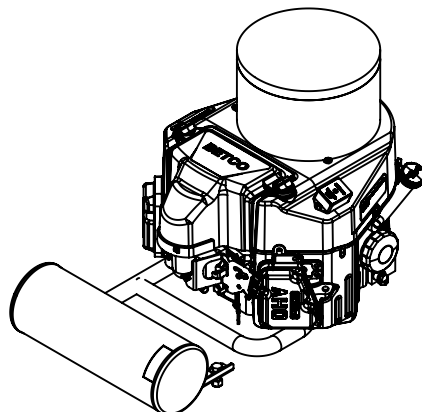

DECK ASSEMBLY

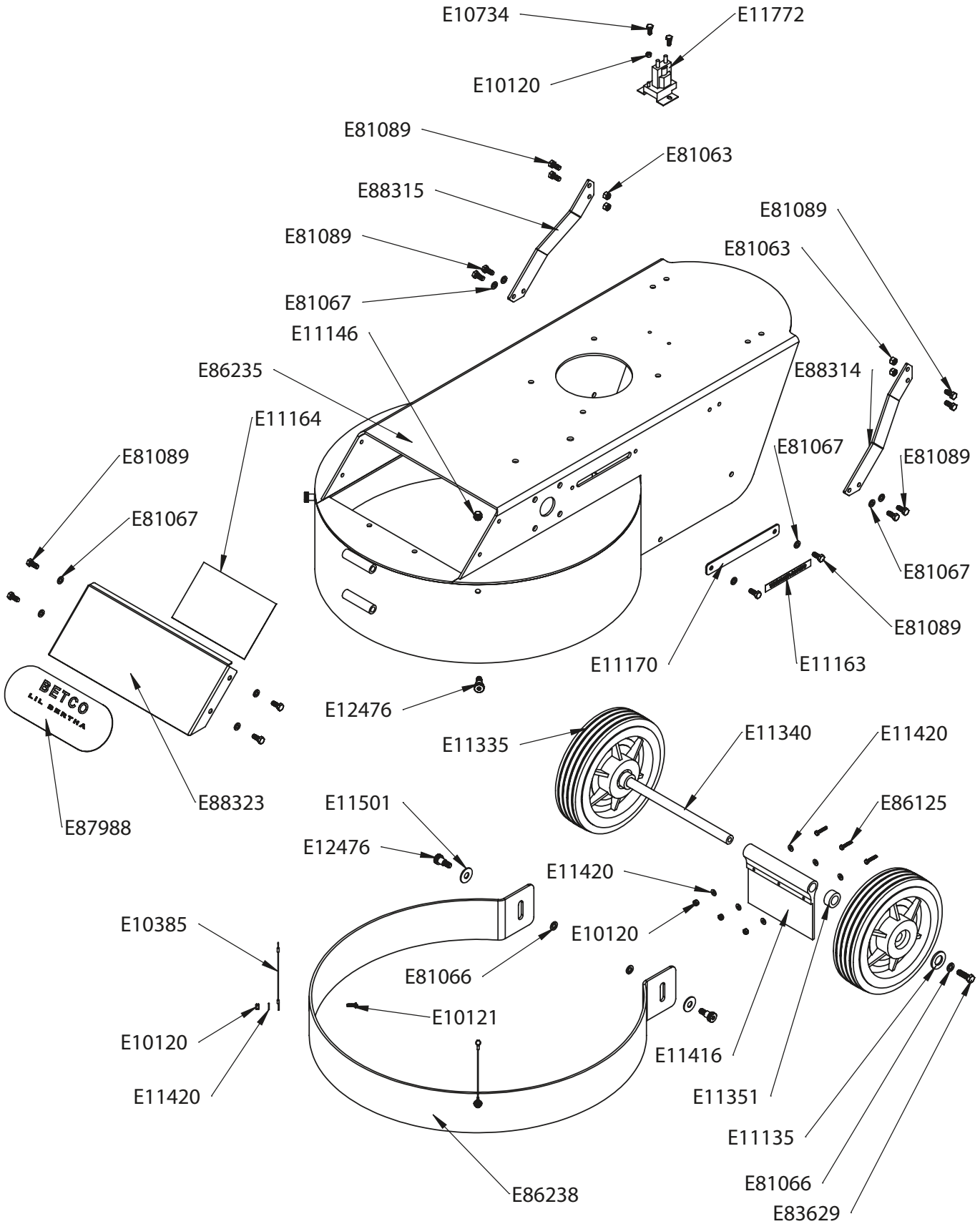

DECK PARTS

PART NUMBER	DESCRIPTION	QTY.
E10120	NYLOC HEX NUT 10-32	6
E10121	PAND HEAD SCREW 10-32 x 5/8 LG	2
E10385	LANYARD 3/64 x 6.0 LG	2
E10734	HEX HEAD BOLT 1/4-20 x 5/8 LG	2
E11135	WASHER, 3/4" SAE, ZINC	2
E11146	NYLOC HEX NUT 3/8-16, ZINC	2
E11163	DECAL TENSIONER ACCESS	1
E11164	DECAL, BELT PATH	1
E11170	TENSIONER ACCESS COVER	1
E11335	WHEEL 10 INCH DIA x 2.50 WIDE	2
E11340	WHEEL AXLE 3/4 OD	1
E11351	SHAFT COLLAR 3/4 ID	2
E11416	RUBBER SPLASH GUARD	1
E11420	FLAT WASHER #10 ZINC	8
E11501	WASHER, 7/16 USS, ZINC	2
E11772	SOLENIOD 12 VDC	1
E12476	SHOULDER SCREW 3/8-16 x 1/2 DIA x 1/2 LG	4
E81063	NYLOC HEX NUT 5/16-18 ZINC	4
E81066	SPLIT LOCK WASHER .375	4
E81067	LOCK WASHER 5/16	10
E81089	HEX HEAD BOLT 5/16-18 x 3/4 LG	14
E83629	HEX HEAD BOLT 3/8-16 x 1-1/4 LG	2
E86125	HEX HEAD BOLT, 10-32 x 1.00 LG	3
E86235	EXTREME STRIP FRAME ASM 24	1
E86238	SPLASH SKIRT	1
E87988	DECAL	1
E88314	HANDLE SUPPORT LEFT	1
E88315	HANDLE SUPPORT RIGHT	1
E88323	FRONT ACCESS PANEL	1

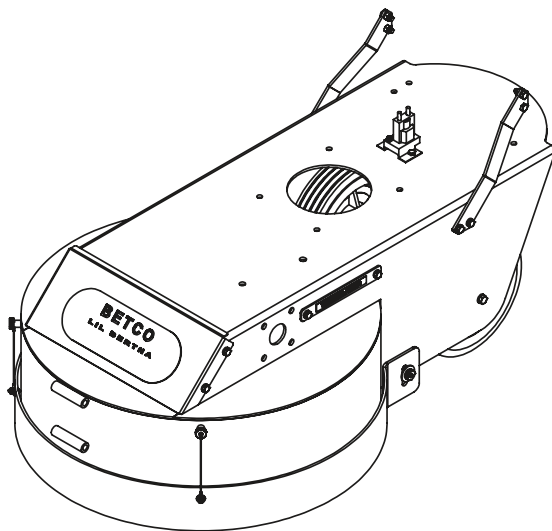

TRANSPORT WHEEL ASSEMBLY

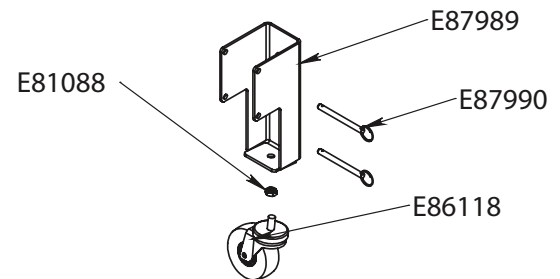

PART NUMBER	DESCRIPTION	QTY.
E81088	NYLOC JAM NUT 1/2-13	1
E86118	3 INCH SWIVEL CASTER	1
E87989	TRANSPORT WHEEL BRACKET	1
E87990	DETENT PIN 3/8 x 4.0, RING	2

MAIN DRIVE SYSTEM

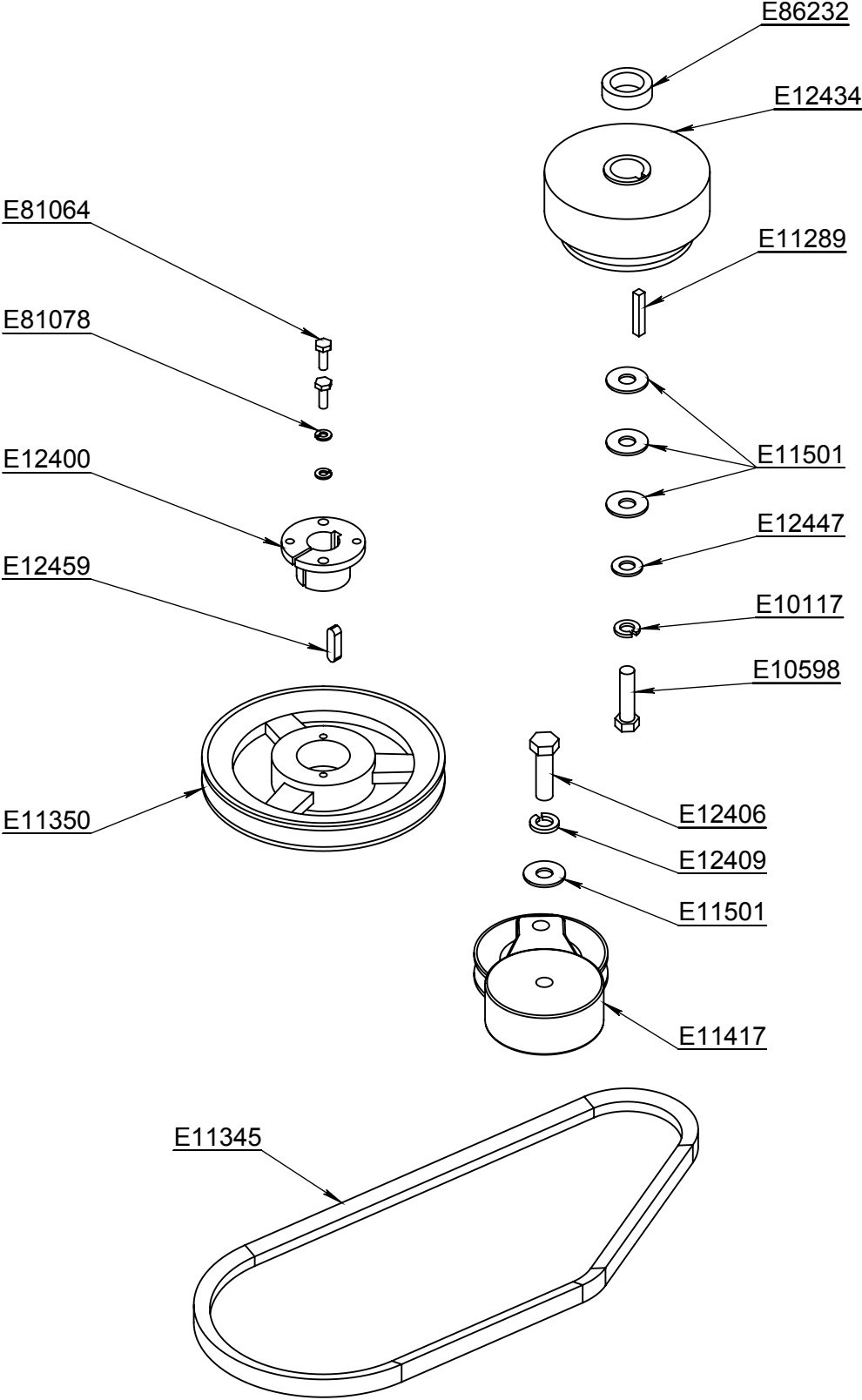

PART NUMBER	Description	QTY.
E10117	Washer, 7/16" Split Lock, Zinc	1
E10598	Screw 7/16"-20 x 1.750 Hex Head, Grade 5, Zinc	1
E11289	Key 1/4" x 1/4" x 1.500"	1
E11345	Belt, B44 V-Belt, 44"	1
E11350	Pulley, BK90H - 8.75 OD	1
E11417	Tensioner Large For Engine	1
E11501	Washer, 7/16" USS, Zinc	4
E12400	Bushing, QT 25mm Taper Lock	1
E12406	Screw, 1/2"-13 x 1.750 Hex Head, Grade 5, Zinc	1
E12409	Washer, 1/2" Split Lock, Zinc	1
E12434	Clutch, Centrifugal 1750 RPM 4" Dia.	1
E12447	Washer, 7/16" SAE, Zinc	1
E12459	Key 8mm x 7mm x 30mm	1
E81064	Screw, 1/4"-20 x 0.750 Hex Head, Grade 5, Zinc	2
E81078	Washer, 1/4" Split Lock, Zinc	2
E86232	Spacer, Clutch Strip Kaw Top 1.000 ID x 0.470 L	1

Note: Not available for purchase assembled.

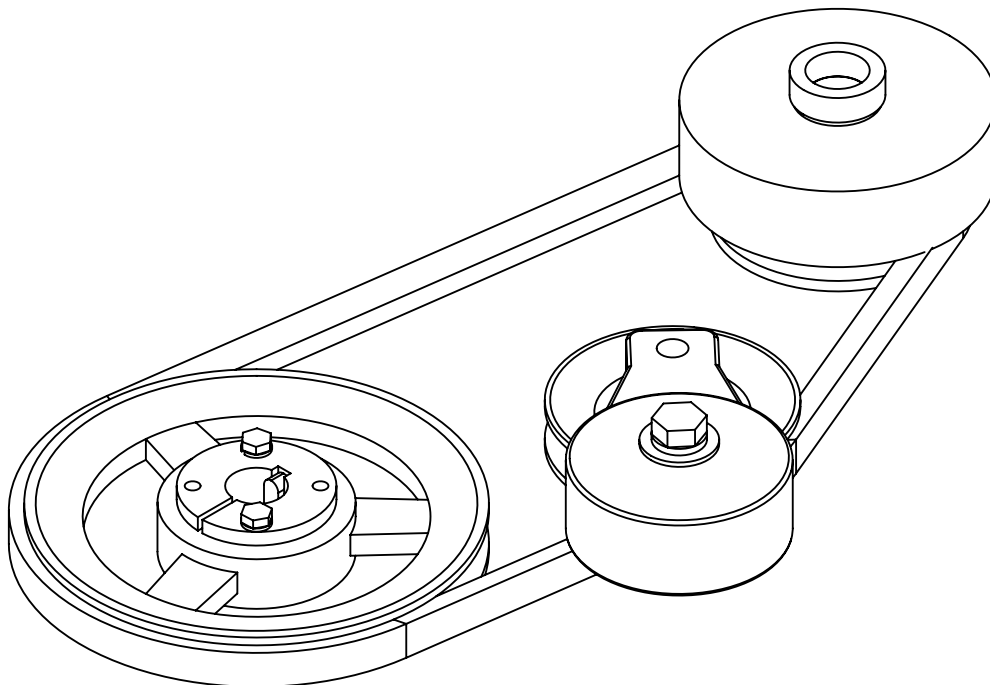

PIVOT BRACKET ASSEMBLY

(For Serial Numbers Before 6999)

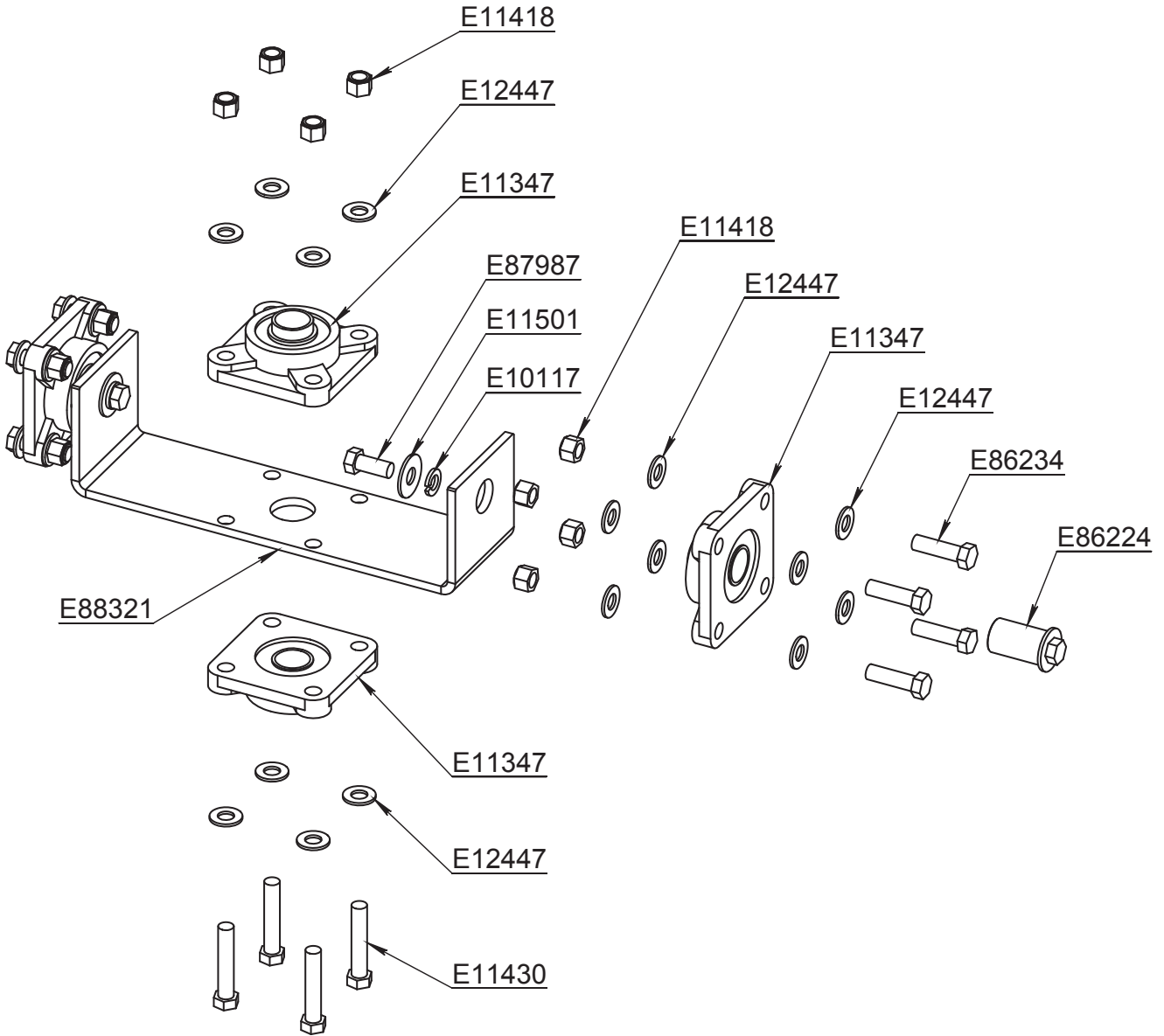

PART NUMBER	Description	QTY.
E10117	Washer, 7/16" Split Lock, Zinc	2
E11347	Flange Bearing AMI UCF 205 Set Screws 2.75 Bolt Spacing	4
E11418	Nut, 7/16"-14, Nylon Lock, Grade 5, Zinc	12
E11430	Screw, 7/16"-14 x 2.250 Hex Head, Grade 5, Zinc	4
E11501	Washer, 7/16" USS, Zinc	2
E12447	Washer, 7/16" SAE, Zinc	24
E86224	Axle, Pivot, 25mm OD x 2.0" L	2
E86234	Screw, 7/16"-14 x 1.500 Hex Head, Grade 5, Zinc	8
E87987	Screw, 7/16"-14 x 1.000 Hex Head, Grade 5, Zinc	2
E88321	Pivot Bracket	1

Note: Not available for purchase assembled.

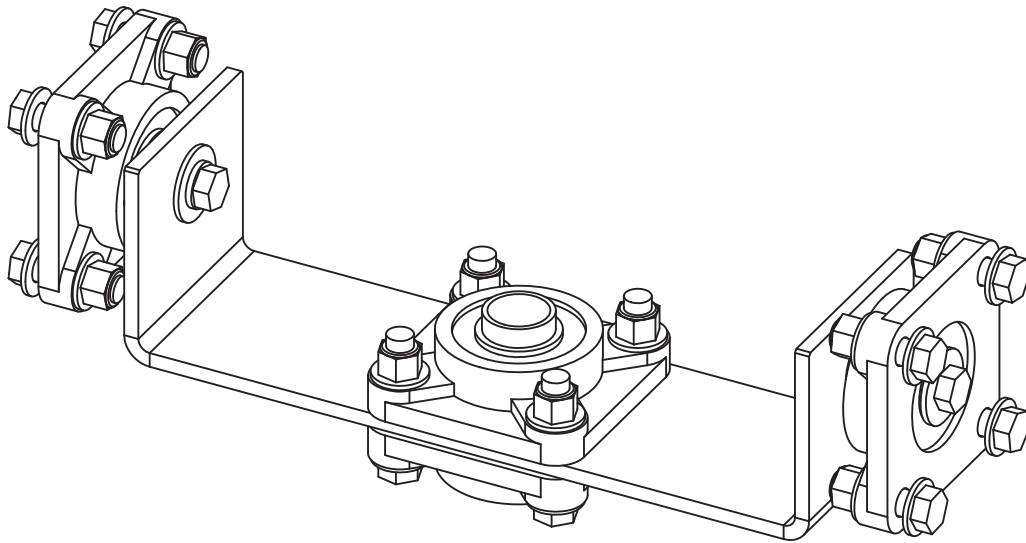

PIVOT BRACKET ASSEMBLY

(For Serial Numbers 7000 and Greater)

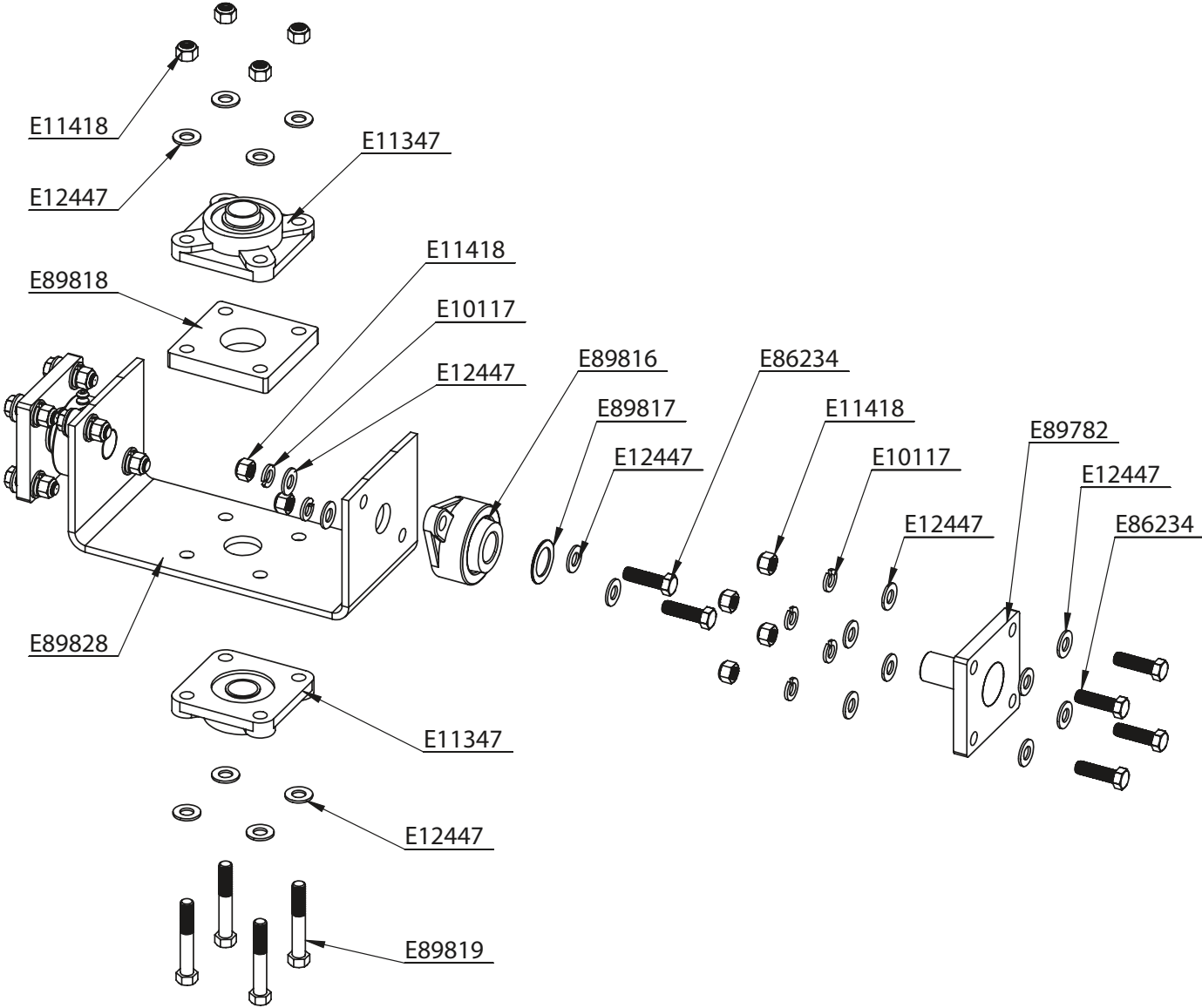

PART NUMBER	DESCRIPTION	QTY.
E10117	SPLIT LOCK WASHER 7/16	12
E11347	FLANGE BEARING AMI UCF 205 SET SCREWS 2.75 BOLT SPACING	2
E11418	NYLOC NUT 7/16-14	16
E12447	FLAT WASHER, 7/16, SAE	32
E86234	HEX HEAD SCREW 7/16-14 x 1-1/2	12
E89782	PIVOT BASE ASM	2
E89816	FLANGE-MOUNTED STEEL BALL BEARING, 1" SHAFT DIAMETER	2
E89817	BRONZE THRUST BEARING 1" I.D. X 1-1/2" OD X 1/16" T	2
E89818	CENTER SHAFT SPACER	1
E89819	HEX BOLT 0.4375-14 x 2.75 LG	4
E89828	PIVOT BRACKET	1

Note: Not available for purchase assembled.

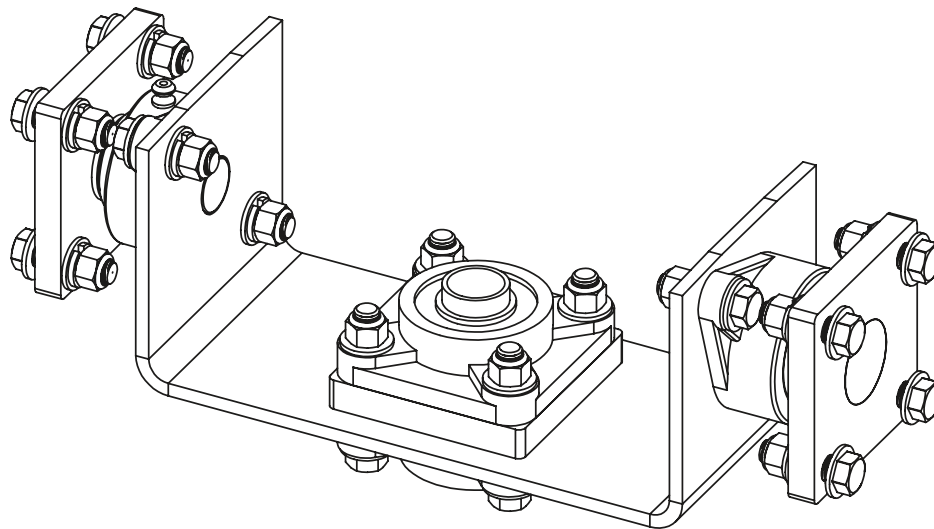

BRUSH PLATE ASSEMBLY

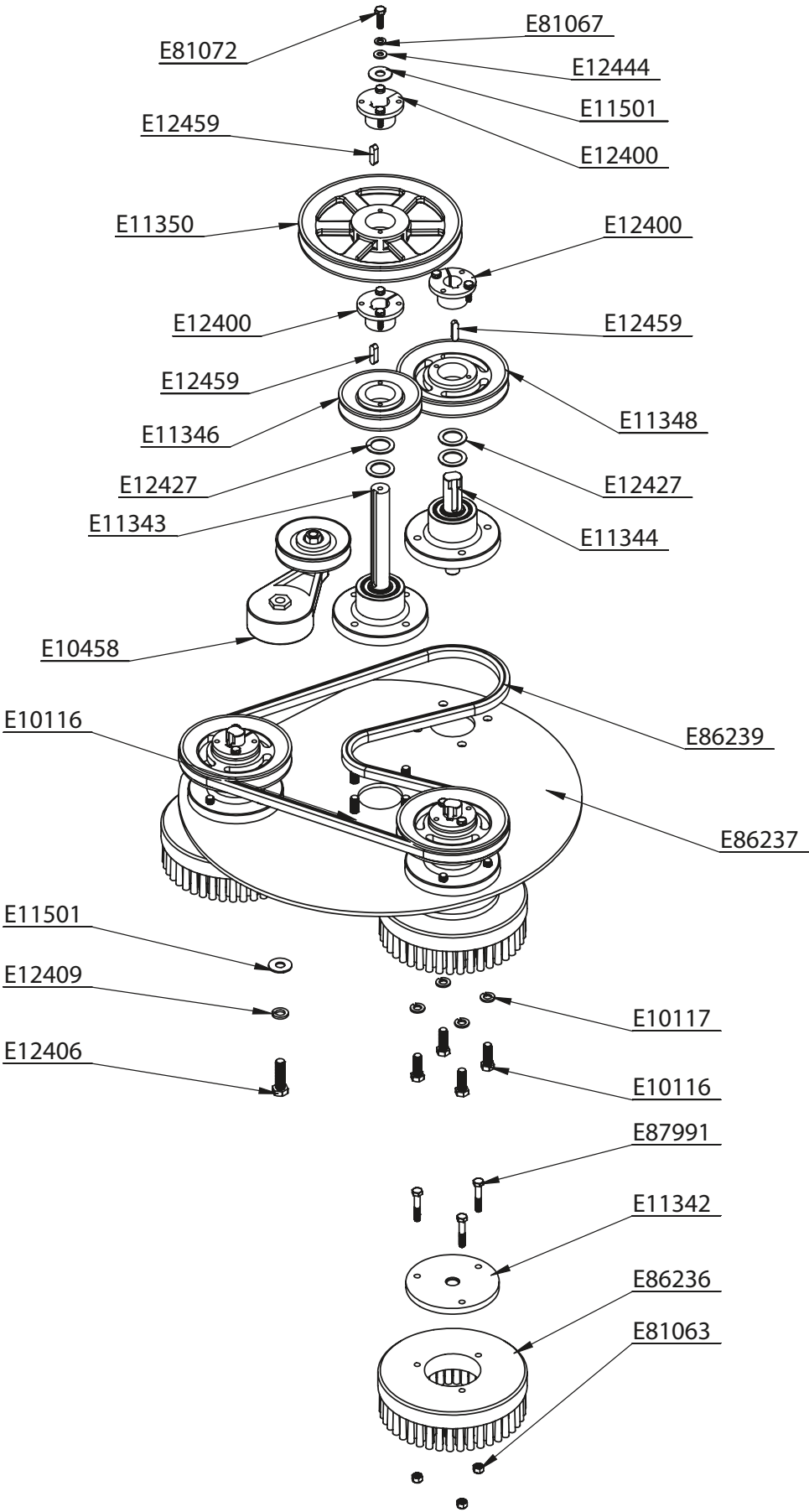

PART NUMBER	DESCRIPTION	QTY.
E10116	HEX HEAD SCREW 7/16-14 x 1-1/4 LG	16
E10117	SPLIT LOCK WASHER 7/16	16
E10458	TENSIONER LARGE FOR BRUSHES	1
E11342	BRUSH MOUNTING PLATE LH	3
E11343	STRIPPER CENTER DRIVE HUB ASSEMBLY	1
E11344	STRIPPER BRUSH DRIVE HUB ASSEMBLY	3
E11346	PULLEY, BK47H - 4.45 OD	1
E11348	PULLEY, BK62H - 5.95 OD	3
E11350	PULLEY, BK90H - 8.75 OD	1
E11501	WASHER, 7/16 USS, ZINC	2
E12400	BUSHING, PULLEY, D25MM QT25MM	5
E12406	HEX HEAD BOLT 1/2-13 x 1-3/4 Lg	1
E12409	WASHER, 1/2 SPLIT LOCK	1
E12427	WASHER 1 ID x 14 GAUGE	8
E12444	FLAT WASHER, 5/16" SAE	1
E12459	MACHINE KEY 8mm x 7 mm x 30mm	5
E81063	NYLOC HEX NUT 5/16-18 ZINC	9
E81067	LOCK WASHER 5/16	1
E81072	HEX HEAD SCREW 5/16-18 x 1.00 Lg	1
E86236	STRIP BRUSH 8" FLARED 3" HOLE	3
E86237	24" BRUSH MOUNTING PLATE	1
E86239	BELT, BB68 DOUBLE V-BELT 68"	1
E87991	HEX HEAD BOLT 5/16-18 x 1-3/4 LG	9

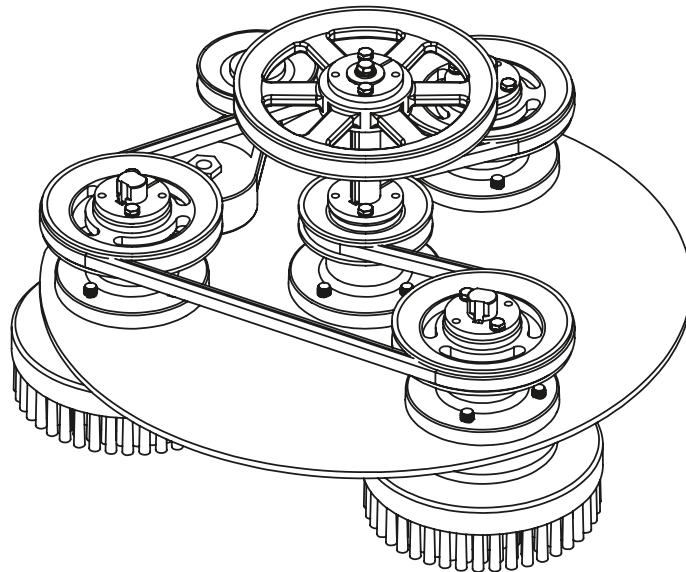

ENGINE MAINTENANCE

KAWASAKI FS481V

PERIODIC MAINTENANCE PLEASE REFER TO ENGINE OWNERS MANUAL FOR MORE INFORMATION	DAILY	EVERY 25 HOURS	EVERY 50 HOURS	EVERY 100 HOURS	EVERY 200 HOURS
Check engine oil level and add if needed	*				
Check and clean engine intake foam and intake paper filter	*				
Check and clean engine cooling air intake filter	*				
General check for loose or lost nuts, screws, oil leakage, fuel hose connection, etc.	*				
Clean air intake foam filter		*			
Clean air intake paper filter		*			
Check belt tension		*			
Change engine oil			*		
Change oil filter				*	
Clean dust and dirt from cylinder and cylinder head cooling fins				*	
Tighten nuts and screws				*	
Clean and regap sparkplugs				*	
Replace air intake foam filter					*
Replace air intake paper filter					*
Replace spark plugs					*
Check and adjust valve clearance					*
Clean combustion chamber					*
Clean and lap valve seating surface					*

IMPORTANT NOTES:

- 1) Change engine oil and oil filter after first 8 hours of operation
- 2) Maintenance should be done by qualified personnel only
- 3) Change foam and paper air intake filters and spark plugs after first 25 hours of operation

ELECTRICAL SCHEMATIC

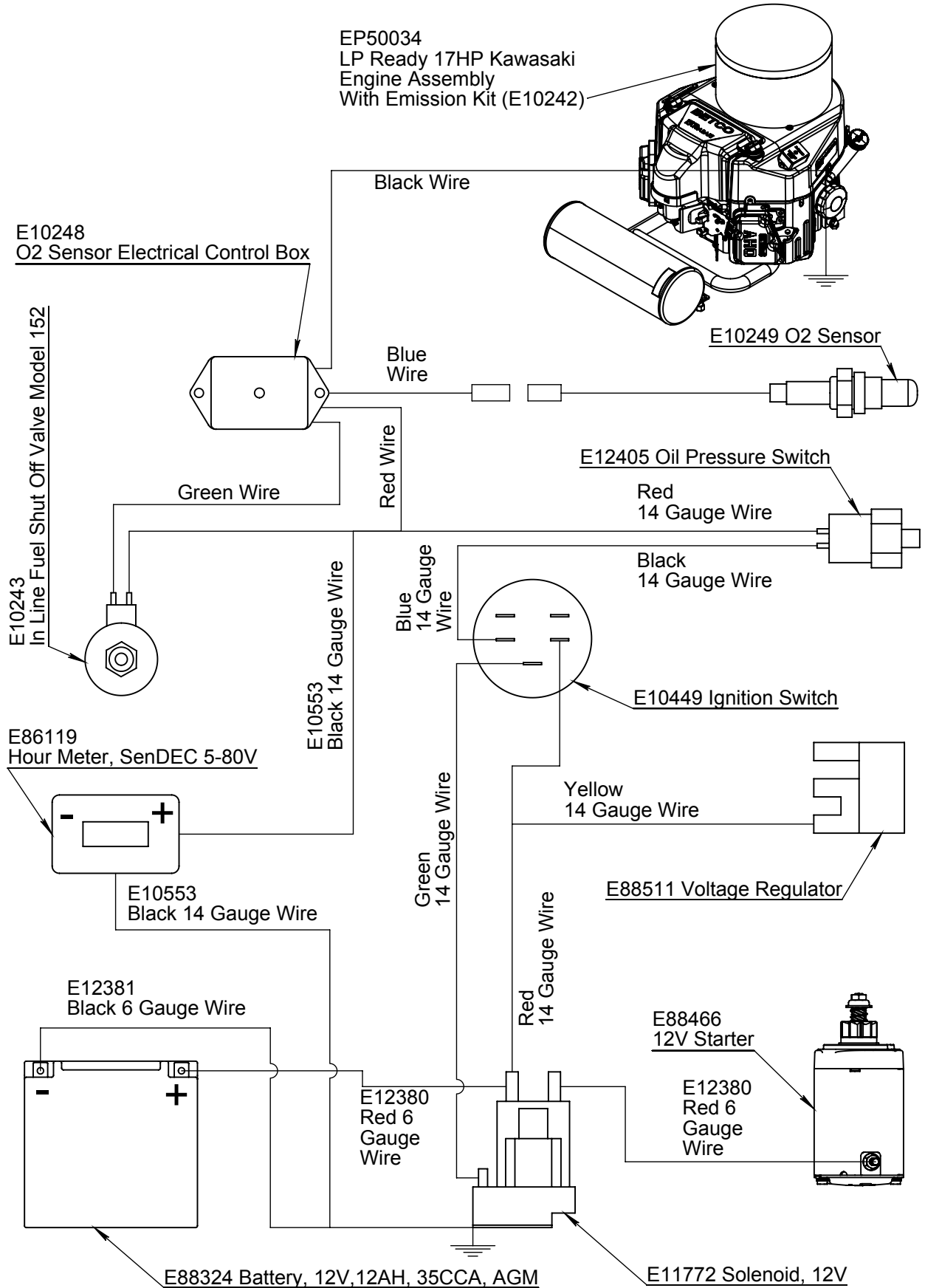

MAIN DRIVE BELT

Removal

1. Remove main drive belt tensioner access plate.
2. Remove front access panel bolts and panel.
3. Loosen main drive belt tensioner bolt using a 3/4" wrench.
4. Through the front access slip the belt up over the main drive pulley of the brush drive plate.
5. You can finish removing the main drive belt through the rear opening of the machine under the handle.

Installation

1. Insert the new main drive belt through the rear opening of the machine under the handle.
2. Place the main drive belt around the clutch while ensuring the main drive belt tensioner pulley is in the correct location.
3. Put the opposite end of the main drive belt on top of the main drive belt pulley of the brush drive plate.
4. Through the front access finish inserting the main drive belt into the main drive belt pulley groove.

Tensioning

1. Insert a 1" wrench into the tensioner access slot onto the main drive belt tensioner hex on the main drive belt tensioner body.
2. Pull the wrench toward the front of the machine to tension the main drive belt.
3. While holding the 1" wrench in place tighten the main drive belt tensioner bolt with a 3/4" wrench.
4. Reposition the 1" wrench to add more tension to the main drive belt.
5. While holding the 1" wrench in place then loosen the main drive belt tensioner bolt with the 3/4" wrench.
6. Repeat steps 2 and 3.
7. Repeat steps 5 and 6 until the main drive belt is tensioned properly. (2 or 3 repetitions)

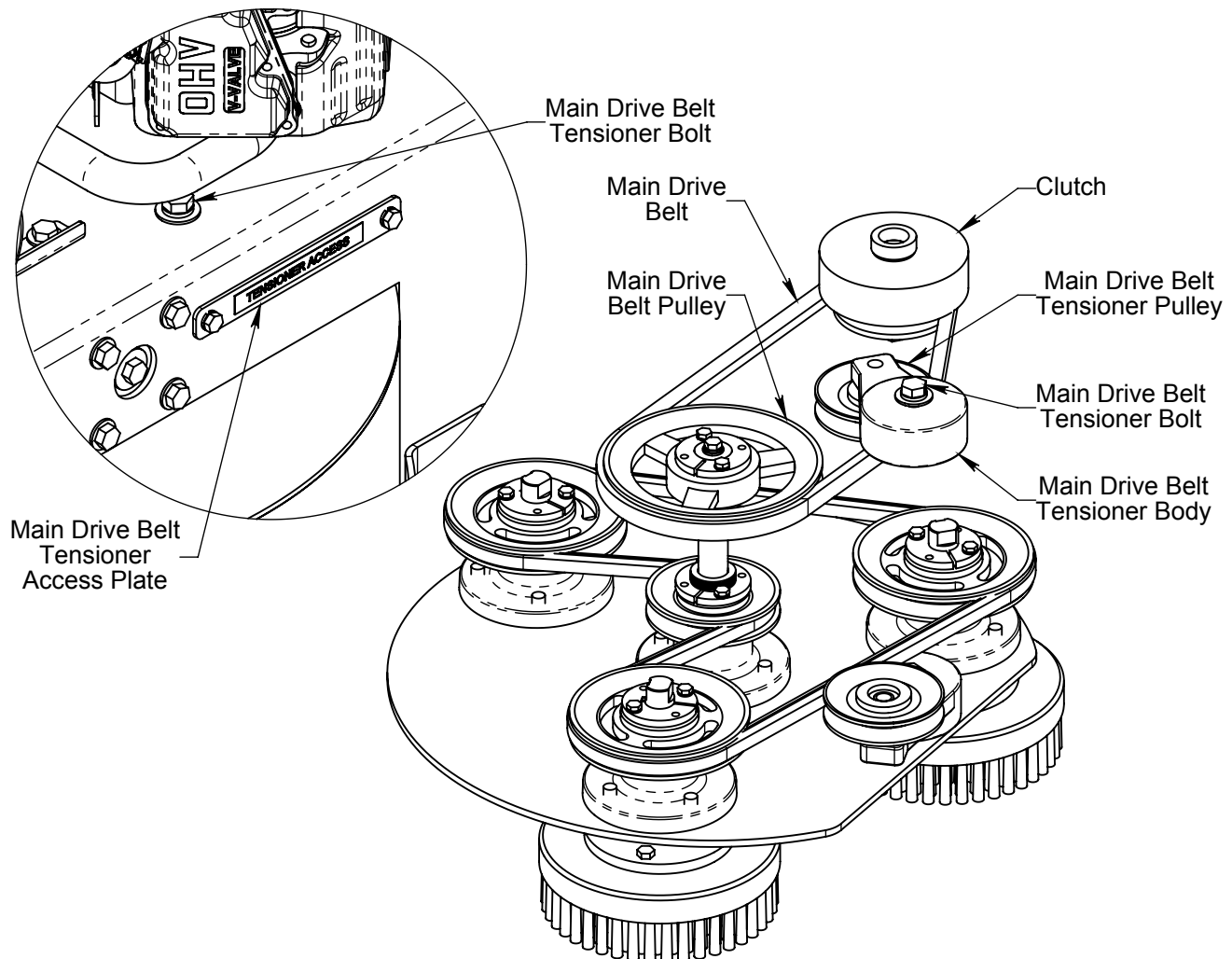

BRUSH PLATE & BELT

Brush Drive Plate Removal

1. Remove front access panel bolts and panel.
2. Loosen main drive belt tensioner bolt using a 3/4" wrench.
3. Through the front access slip the main drive belt up over the main drive pulley of the brush drive plate.
4. Remove pivot bracket axle bolts.
5. Slide pivot bracket axles out from both sides.
6. Tilt machine back at handle and pull backward until it clears the brush drive unit.

Brush Drive Belt Removal

1. Loosen brush drive belt tensioner pulley bolt, located on brush side of plate, using a 3/4" wrench.
2. Slide the belt off one of the three brush pulleys.
3. Finish removing the belt from the rest of the pulleys.

Brush Drive Belt Installation

1. Place the new belt around the center pulley as shown below.
2. Now route the belt around each of the brush drive pulleys as shown below.

Brush Drive Belt Tensioning

1. Place a 1" wrench on the tensioner hex on the top of the brush drive belt tensioner body.
2. Pull the wrench toward the brush drive belt tensioner pulley to tension the belt.
3. While holding the 1" wrench in place tighten the brush drive belt tensioner bolt, on the brush side of the plate, using a 3/4" wrench.

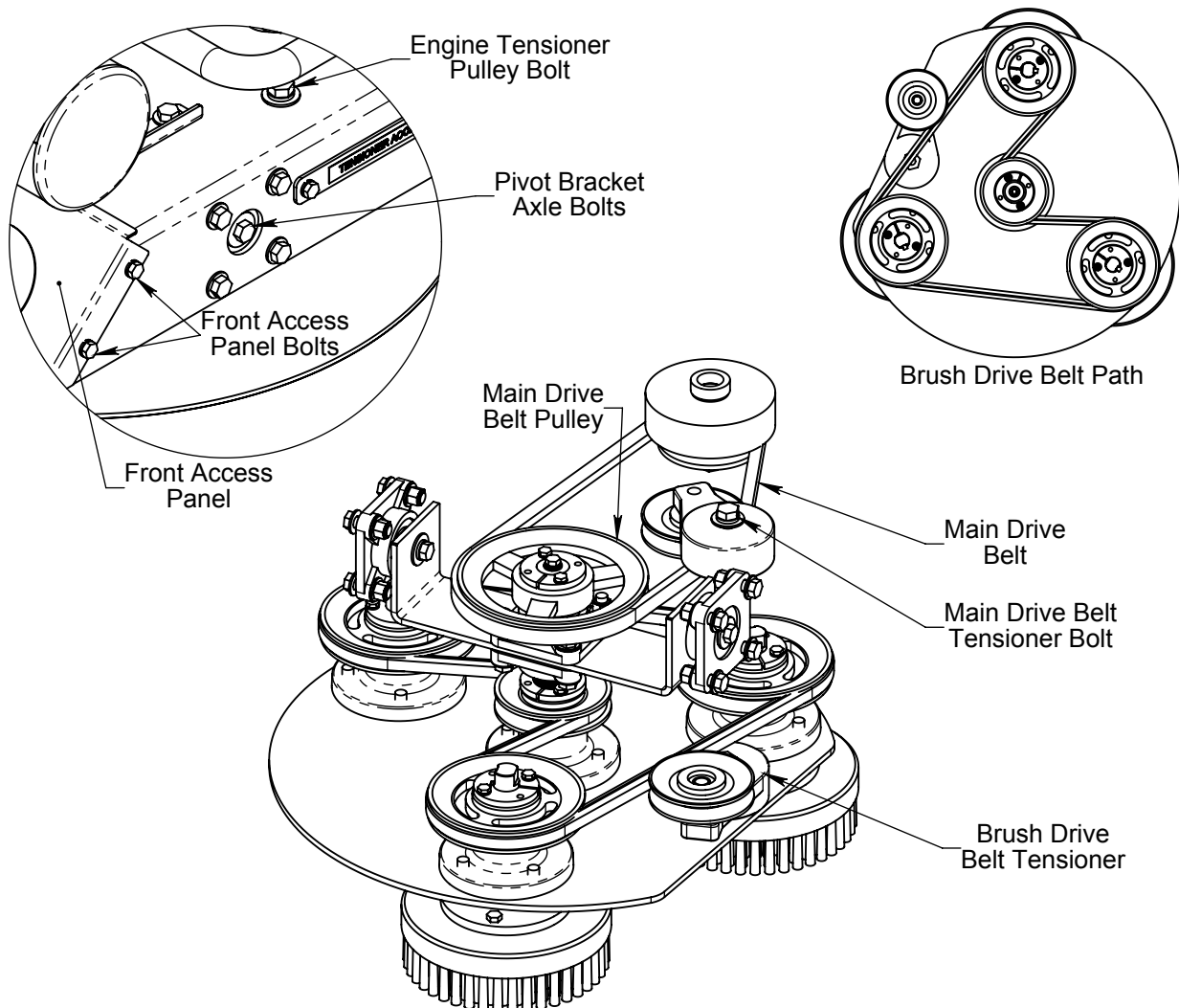

BRUSH CHANGE

1. Remove propane tank.
2. Remove front access panel to gain access to the brush drive shaft tops.
3. Lay the machine on its side with the brush drive plate installed.
4. The brush drive shaft and brush mount plate are LEFT HAND THREADS.
5. Using a 3/4" open end wrench place it on the wrench flats of the brush drive shaft top.
6. Place an 1 1/4" socket in the center of the brush mount plate on the bristle side.
7. Unscrew the brush mount plate from the brush drive shaft while securing the brush drive shaft with the 3/4" wrench.
8. Now you'll need to remove the brush from the brush mount plate.
9. Using a 1/2" wrench and 1/2" socket unscrew the nuts which hold the brush onto the brush mount plate.

Note: When reassembling brush and brush mounting plate place bolts in through the brush mount plate down through brush and put nuts on the bristle side of the brush.

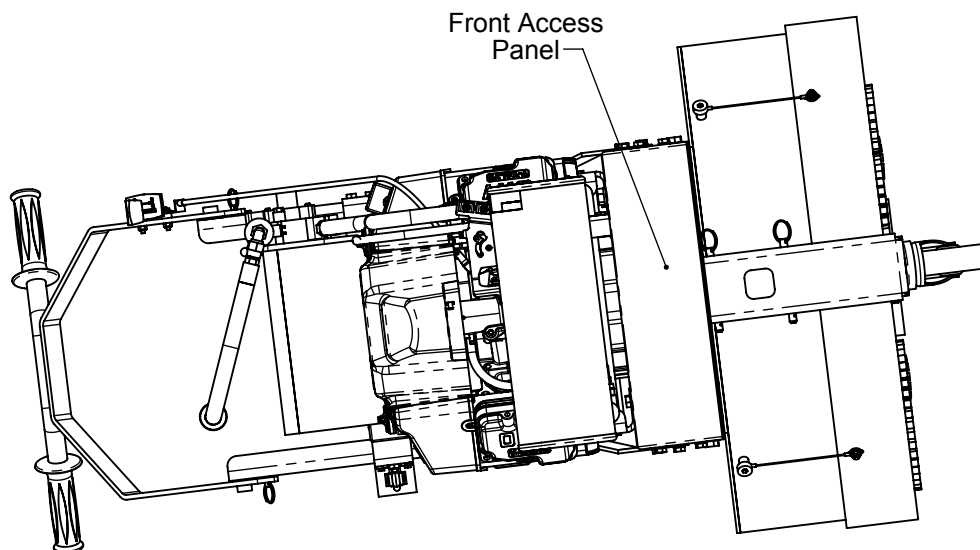
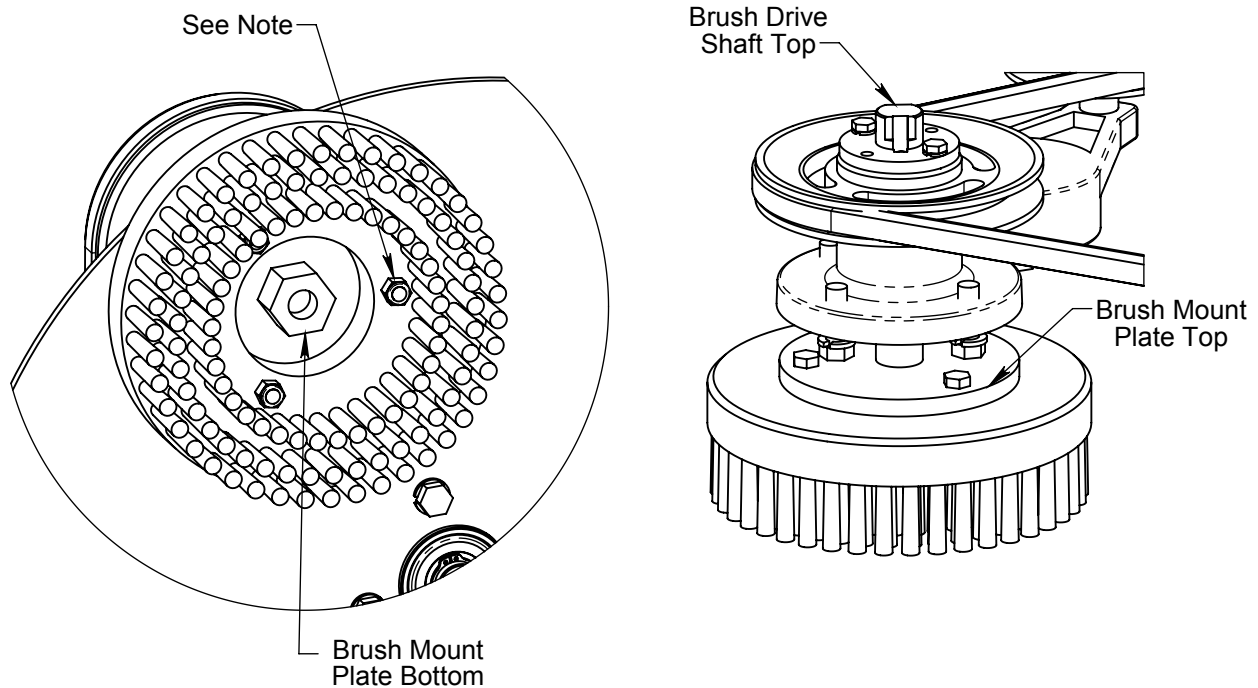

TROUBLESHOOTING

PROBLEM	CAUSE	POSSIBLE SOLUTION
Engine will not turn over	Battery is dead	Recharge battery or replace if necessary
	Loose wire or bad connection	Check wires and connections
	Bad electrical component	Replace bad component
	Fuel system problem	Refer to engine owner's manual and read IMPORTANT below
Engine turns over, but will not start	Propane tank shut off valve in off position	Open propane tank shut off valve completely
	Low oil	Add oil
	Fuel system problem	Refer to engine owner's manual and read IMPORTANT below
	Propane tank empty	Fill propane tank
	Engine problem	Refer to engine owner's manual and read IMPORTANT below
Hard to start	Throttle lever in slow position	Push throttle lever to fast position
	Propane tank shut off valve not fully open	Open propane tank shut off valve completely
	Some type of engine problem	Refer to engine owner's manual and read IMPORTANT below
Engine stops suddenly and will not restart	Out of propane	Replace propane tank with full propane tank
	Low oil	Add oil
Engine overheats	Intake air filter is dirty	Remove air intake filter and clean
	Incorrect oil level	Add or remove oil to achieve proper oil level
Can't remove brushes	Turning brushes the wrong direction	Turn clockwise to remove. Threads are LEFT HAND
Poor stripping performance or leaves wax on the floor	Brushes worn and have 3/4" bristle length or less	Change the brushes
	Brush or main drive belt slipping	Tension belts or replace belts if worn out
	Problem with stripper	Check dilution ratio or try alternative stripper
Excessive splashing	Splash guard too high off floor	Adjust splash guard down
Solution pushed by splash guard	Splash guard too low	Adjust splash guard up
Brushes not turning, turning slow or smell burning rubber	Brush or main drive belt slipping	Tension belts or replace belts if worn out
	Floor too rough to overcome friction, may happen on rough concrete surface	Check belts for proper tensioning or for excessive wear and ensure there is plenty of liquid on the floor.
Lacks power	Some type of engine problem	Refer to engine owner's manual and read IMPORTANT below
Engine stops and will restart, but stops again	Emission shut-down system engaged	Refer to engine owner's manual and read IMPORTANT below
Nothing here fixes the problem	Problem could have several causes	Read IMPORTANT below

IMPORTANT: Propane fueled combustion engines produce dangerous gases and must be serviced by authorized service personnel trained specifically to service propane fueled engines and fuel systems. The troubleshooting tips are not intended to take the place of authorized service personnel. If you are unsure of what to do contact an authorized service personnel. Before working on this machine you must be familiar with the safety instructions in this manual.

EMISSION CONTROL WARRANTY STATEMENT

YOUR WARRANTY RIGHTS AND OBLIGATIONS

The California Air Resources Board and Betco Corporation are pleased to explain the emissions control system warranty on your small off-road engine (SORE). In California and the other 49 States, new SORE must be designed, built and equipped to meet stringent anti-smog standards. Betco Corporation must warrant the emission control system on your SORE for the period of time listed below provided there has been no abuse, neglect or improper maintenance of your SORE.

Your emission control system may include parts such as the carburetor, fuel-injection system, the ignition system, catalytic converter, fuel tanks, fuel lines, fuel caps, valves, canisters, filters, vapor hoses, clamps, connectors, and other associated emission-related components.

Where a warrantable condition exists, Betco Corporation will repair your SORE at no cost to you including diagnosis, parts and labor.

MANUFACTURER'S WARRANTY COVERAGE

The emission control system is warranted for two years. If any emission-related part on your equipment is defective, the part will be repaired or replaced by Betco Corporation.

OWNER'S WARRANTY RESPONSIBILITIES

As the small off-road engine (SORE) owner, you are responsible for the performance of the required maintenance listed in your owner's manual. Betco Corporation recommends that you retain all receipts covering maintenance of your SORE engine, but Betco Corporation cannot deny warranty solely for the lack of receipts or for your failure to ensure the performance of all scheduled maintenance.

As the SORE owner you should however be aware that Betco Corporation may deny your warranty if your SORE or its part has failed due to abuse, neglect, improper maintenance or unapproved modification.

You are responsible for presenting your utility equipment engine to a Betco Corporation distribution center as soon as the problem exists. The warranty repairs should be completed within a reasonable amount of time, not to exceed 30 days. If you have any questions regarding your warranty rights and responsibilities, you should contact Betco Corporation at 1-888-GO-BETCO (1-888-462-3826).

Betco Corporation
1001 Brown Ave.
P.O. Box 3127
Toledo, Ohio 43607
USA

GENERAL EMISSIONS WARRANTY COVERAGE

Betco Corporation warrants to the ultimate purchaser and each subsequent purchaser that the equipment is designed, built and equipped so as to conform with all applicable regulations; and free from defects in materials and workmanship that cause the failure of a warranted part to be identical in all material respects to that part as described in Betco Corporation's application for certification.

The warranty period begins on the date the equipment is delivered to an ultimate purchaser or first placed into service. The warranty period is two years.

Subject to certain conditions and exclusions as stated below, the warranty on emission-related parts is as follows:

1. Any warranted part that is not scheduled for replacement as required maintenance in the written instructions supplied, is warranted for the warranty period stated above. If the part fails during the period of warranty coverage, the part will be repaired or replaced by Betco Corporation according to subsection (4) below. Any such part repaired or replaced under warranty will be warranted for the remainder of the period.
2. Any warranted part that is scheduled only for regular inspection in the written instructions supplied is warranted for the warranty period stated above. Any such part repaired or replaced under warranty will be warranted for the remaining warranty period.

EMISSION CONTROL WARRANTY STATEMENT

3. Any warranted part that is scheduled for replacement as required maintenance in the written instructions supplied is warranted for the period of time before the first scheduled replacement date for that part. If the part fails before the first scheduled replacement, the part will be repaired or replaced by Betco Corporation according to subsection (4) below. Any such part repaired or replaced under warranty will be warranted for the remainder of the period prior to the first scheduled replacement point for the part.
4. Repair or replacement of any warranted part under the warranty provisions herein must be performed at a warranty station at no charge to the owner.
5. Notwithstanding the provisions herein, warranty services or repairs will be provided at all of our distribution centers that are franchised to service the subject engines or equipment.
6. The SORE owner will not be charged for diagnostic labor that is directly associated with diagnosis of a defective, emission-related warranted part, provided that such diagnostic work is performed at a warranty station.
7. Betco Corporation is liable for damages to other engine or equipment components proximately caused by a failure under warranty of any warranted part.
8. Throughout the SORE warranty period stated above, Betco Corporation will maintain a supply of warranted parts sufficient to meet the expected demand for such parts.
9. Any replacement part may be used in the performance of any warranty maintenance or repairs and must be provided without charge to the owner. Such use will not reduce the warranty obligations of Betco Corporation.
10. Add-on or modified parts that are not exempted by the Air Resources Board may not be used. The use of any non-exempted add-on or modified parts by the ultimate purchaser will be grounds for disallowing a warranty claims. Betco Corporation will not be liable to warrant failures of warranted parts caused by the use of a non-exempted add-on or modified part.

WARRANTED PARTS

The repair or replacement of any warranted part otherwise eligible for warranty coverage may be excluded from such warranty coverage if Betco Corporation demonstrates that the SORE has been abused, neglected, or improperly maintained, and that such abuse, neglect, or improper maintenance was the direct cause of the need for repair or replacement of the part. That notwithstanding, any adjustment of a component that has a factory installed, and properly operating, adjustment limiting device is still eligible for warranty coverage. The following emission warranty parts are covered:

1. Fuel system: carburetor, pressure regulator, and fuel lock off
2. Ignition system: spark plug, ignition coil assembly, and voltage regulator
3. Intake system: intake manifold and air filter
4. Exhaust system: exhaust manifold and catalytic converter
5. Miscellaneous items used in above systems: hoses, connectors, and assemblies.

BETCO US WARRANTY POLICY

10 year coverage

Subject to the conditions stated below, Betco warrants parts and labor on rotationally molded polyethylene tanks/ housings and injection molded vacuum head assemblies to be free from defects in materials and workmanship for a period of ten years to the original purchaser.

3 Year Coverage

Subject to the conditions stated below, Betco warrants parts and labor on all other Betco components to be free from defects in materials and workmanship for a period of three years to the original purchaser.

- Lithium Ion battery for MotoMop™ is a full 3 years

1 Year Coverage

Subject to the conditions stated below, Betco offers a limited warranty on parts and labor on the following equipment: parts and accessories to be free from defects in materials and workmanship for a period of one year to the original purchaser.

- PowerUp™ 14 Upright Vacuum: #E29990-00
- Bac Pac Lite Vacuum: #85903-00
- FiberPRO® Floor Dryer: #85507-00
- WORKMAN™ Series Vacuums: #85024-00, #85025-00, #83012-00, #85027-00
- All Tools and Accessories
- All Battery Chargers
- Deep cycle batteries are pro-rated for 1 year

Allowable Travel Time Warranty Reimbursement:

Eligible equipment: All battery and propane powered equipment products. Warranty period: 90 days from date of sale to the original purchaser. A maximum 180 mile round trip at 50 cents per mile will be allowed for warranty consideration.

Propane Machine Warranty:

Kawasaki/Subaru engines are warranted by Kawasaki/Subaru for a period of 2 years against manufacturer defects. All other components (except wear items)* are warranted by Betco for a period of 3 years.

***Wear Items exempt from Warranty consideration include but may not be limited to: power cords, transport wheels, vacuum bags, belts, squeegee blades, pad drivers, clutch plates, handle grips, filters, screens, throttle cables, brushes and carbon brushes.**

Subject to the conditions and exceptions stated in this warranty, Betco warrants the Betco products to be free from defects in material and workmanship, under normal use and service, for the periods listed under the warranty policy to the original purchaser. At any time during the warranty period, Betco will furnish replacement parts for the Betco parts to the original purchaser. Such parts will be furnished and charged including transportation costs, to the original owner through any Betco authorized Service Distributor. If the original part is returned within the warranty policy period from date of delivery for inspection by Betco and is found to be defective the owner will be credited for the cost of replacement parts plus shipping and handling. Replacement parts that have become defective through wear or abuse are not included in this warranty.

This warranty does not apply to damage or defect caused by accident, misuse, negligence, fire, or to any Betco product which has been serviced or repaired by other than an authorized Betco Service Distributor or Betco factory personnel. This warranty is void if products are used for any purpose other than that which was intended. There are no other warranties expressed or implied. In no event shall Betco be liable for incidental or consequential damages or any damage to person or property. (Please note some states do not allow the exclusion or limitations for incidental and consequential damages).

