

WD18

ORDER #85007

18 Gallon Wet/Dry Vacuum

FEATURES

- Powerful 1.6 hp Motor
- 50' Power Cord
- Motor Housing Made From Triax material
- 10' Vacuum Hose Swivel Lock at Tank
- 10 Year Tank/Motor Housing Warranty

The Betco series of wet/dry tank vacuums are engineered for easy use, operator safety and heavy duty performance. With a low 62 dB noise rating you'll hardly hear it working but will definitely see the results. Durability won't be a concern with these, because the motor housing is made of Triax, the same material used in riot helmets! All Betco tank vacuums are CSA safety tested and certified.

WARRANTY

Tank: 10 Year
Triax Motor Housing: 10 Year
Other components: 3 Year*

*Please refer to Betco Equipment Price/Product Guide for complete equipment warranty information.



Model shown:
#85008 WDI8DLY
w/#85200 optional
squeegee kit.

Authorized Betco Distributor:



SPECIFICATIONS

- Motor: 1.6 hp 2 stage bypass
- Amp Draw: 11.3 amps
- Volts: 115AC
- Cord: 50' 16/3 Ga.
- Noise Level: 62 dB
- Weight: 35 lbs.
- CSA Tested and Certified

APPLICATIONS

- Wet or Dry Floor Cleaning
- Construction Clean Up
- Automotive Detailing

OPTIONS

Wet or Dry Tool Kit #85216
Front Mount Squeegee Assembly #85200
Cartridge Type Filter #85208
Paper Filter Bags #85206

Better Resources. Better Results.



1001 Brown Avenue • P.O. Box 3127 • Toledo, Ohio 43607-0127

©All Rights Reserved 5/99 • Reorder #85007

BETCO BETTER SOLUTIONS

OFFERING THE TOTAL SOLUTION.

Betco is now the only manufacturer with a complete line of products for the cleaning professional.



Complete Floor Machine, Vacuum and Scrubber Line.



Complete Carpet Care Program.

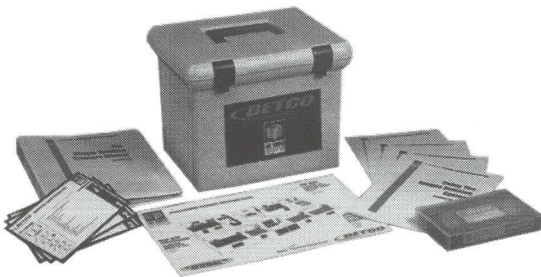

Complete Training Programs.



Complete Chemical Programs, Cleaners, Floor Care and specialties.



Complete Hand Cleaner Line.



Nationwide Support.

Let Betco be your single source manufacturer.

Better Resources. Better Results.
BETCO®

Wet/Dry Vacuum 18 Gallon

Parts Schematic



WD18
WD18DLY

Item #85007
Item #85008

Better Resources. Better Results.
BETCO[®]

BETCO

WET/DRY

WD18

85007

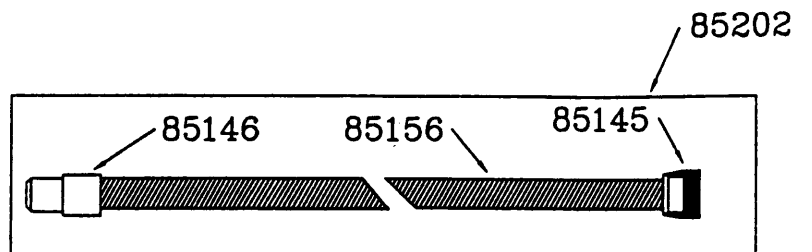
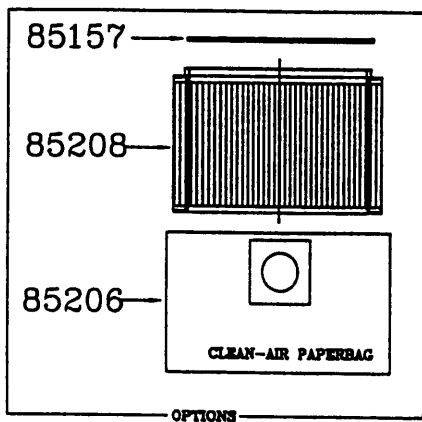
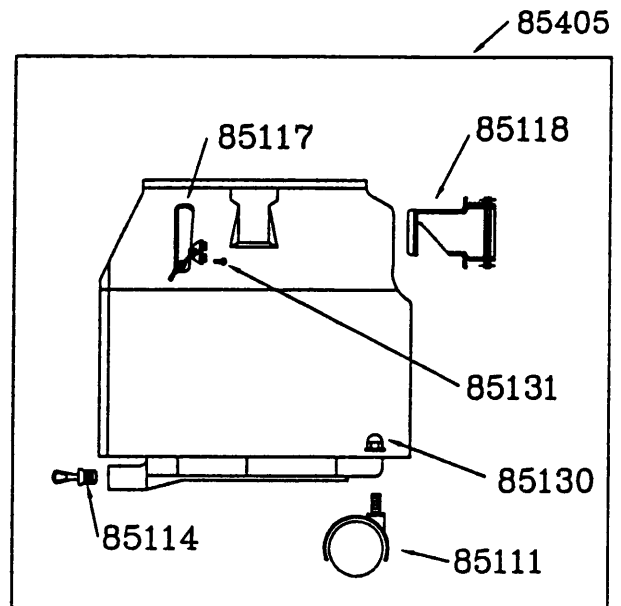
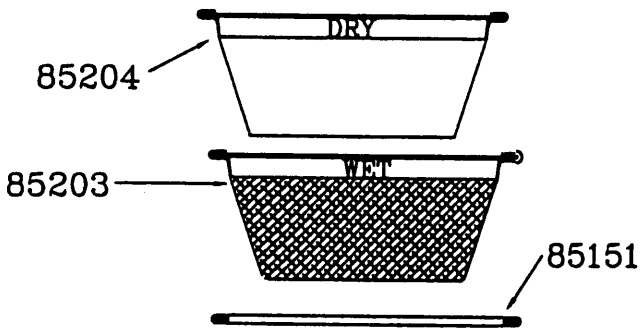
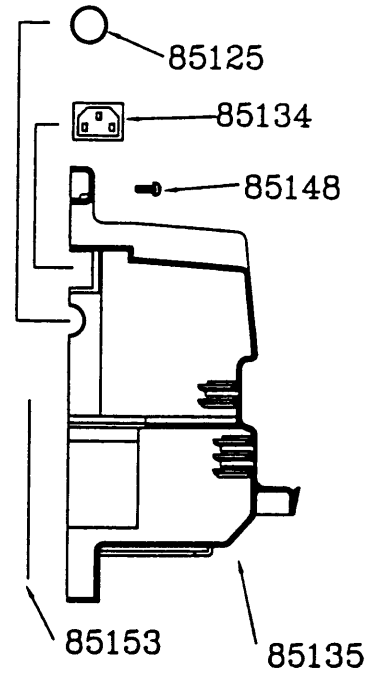
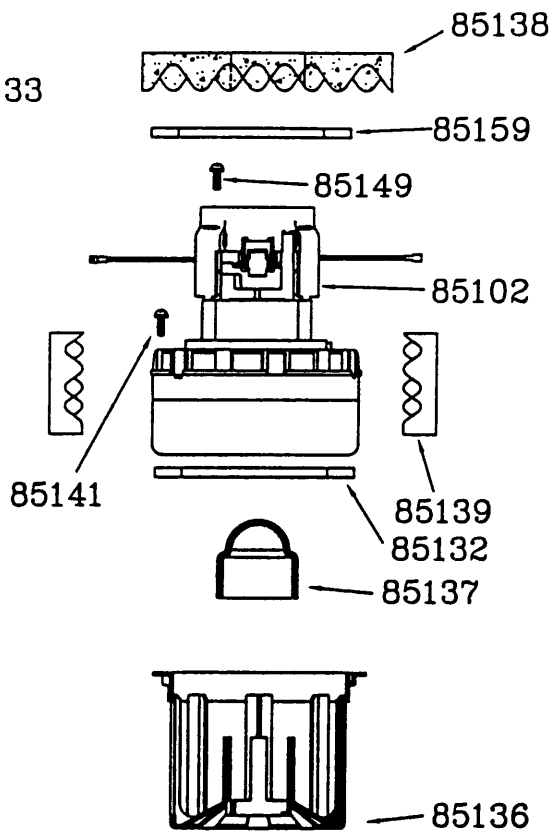
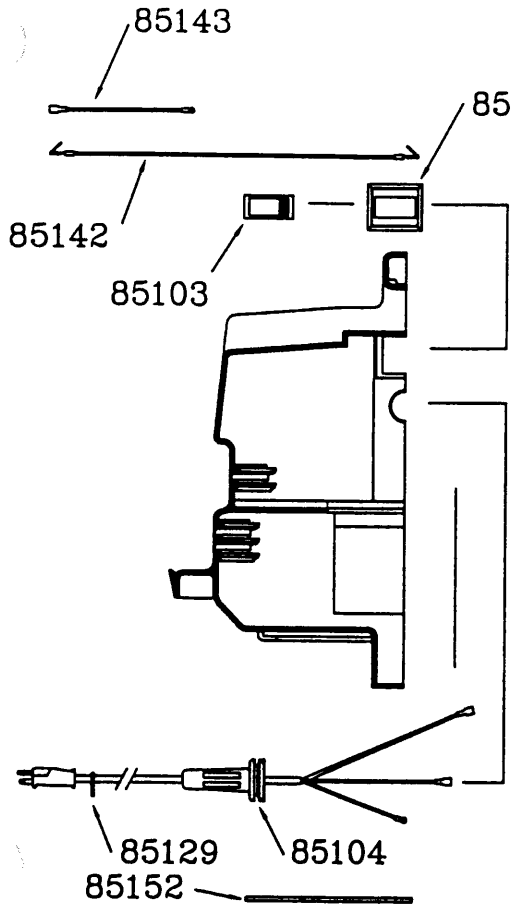

ITEM	DESCRIPTION	QTY REQ
85102	MOTOR SMALL BI-PASS	1
85103	ROCKER SWITCH	1
85104	CORD ASSEMBLY 16/3 X 50'	1
85111	CASTERS DUAL WHEEL	5
85114	DRAIN HOSE PLUG ASSEMBLY	1
85117	TANK CLAMP	2
85118	INLET DEFLECTOR	1
85125	DOME PLUG	1
85129	CORD GRIP	1
85130	3/8-16 ACORN NUT	5
85131	#10 X 3/8 PHS HI-LO	4
85132	UNIVERSAL MOTOR GASKET	1
85133	SWITCH PLATE	1
85134	POWER OUTLET PLUG	1
85135	MOTOR HOUSING	2
85136	FILTER CAGE LARGE	1
85137	FLOAT SHUT OFF	1
85138	TOP FOAM DISK	1
85139	LOWER ACCOUSTIC FOAM	8
85141	#10-16 X1 PHS	2
85142	BLACK WIRE ASSEMBLY	1
85143	GROUND WIRE ASSEMBLY	1
85145	HOSE COUPLING	1
85146	1 1/2 HOSE CUFF	1
85147	HOSE CUFF 1 1/2 TO 1 1/4	1
85148	#8 X 3/4 PHS HI-LO	12
85149	#10-32 X 3/8 PHS - GROUND	2
85151	FILTER GASKET	1
85152	JOGGER RING	1
85153	HOUSING GASKET	1
85156	1 1/2 VACUUM HOSE	1
85159	UPPER MOTOR GASKET	1
85202	VACUUM HOSE ASSEMBLY	1
85203	WET FILTER	1
85204	LARGE DRY FILTER	1
85405	18 GAL TANK ASS'Y C/W CASTERS	1

OPTIONS

85208	FILTER HEPA LARGE	1
85157	CLAMP HEPA FILTER	1
85206	CLEAN-AIR FILTER BAG (10 PAK)	1

FEBRUARY 2000

BETCO

WET/DRY

WD18 DLY

85008

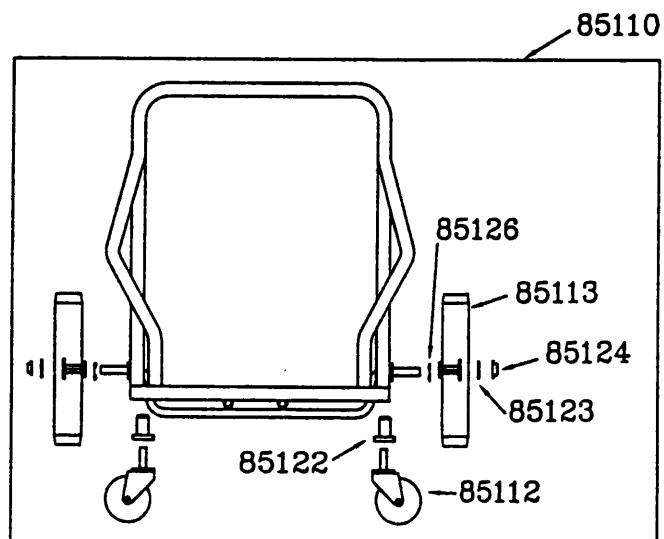
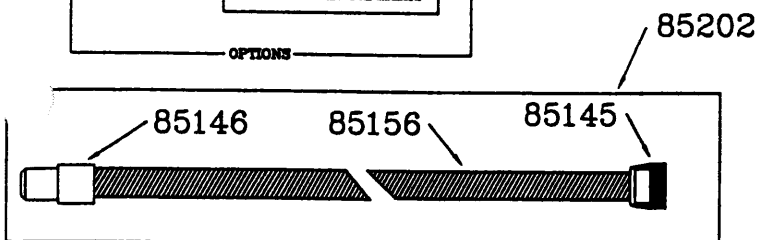
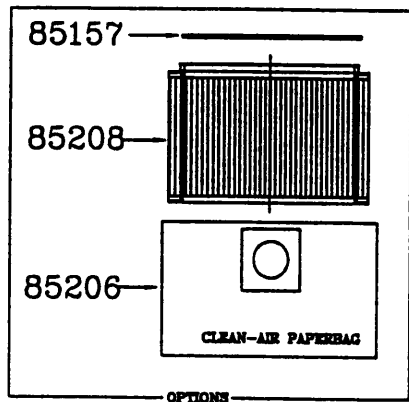
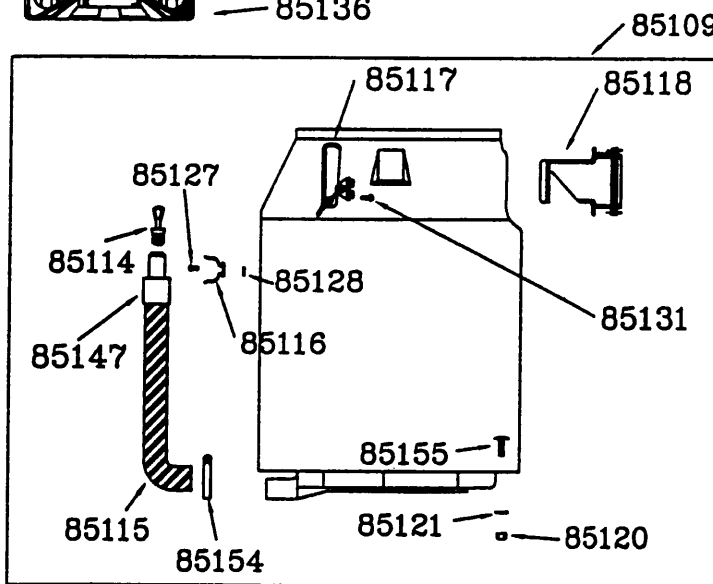
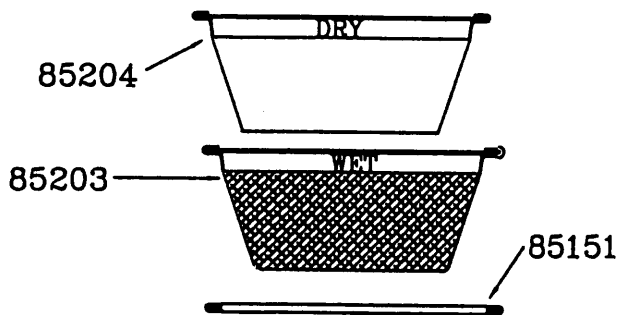
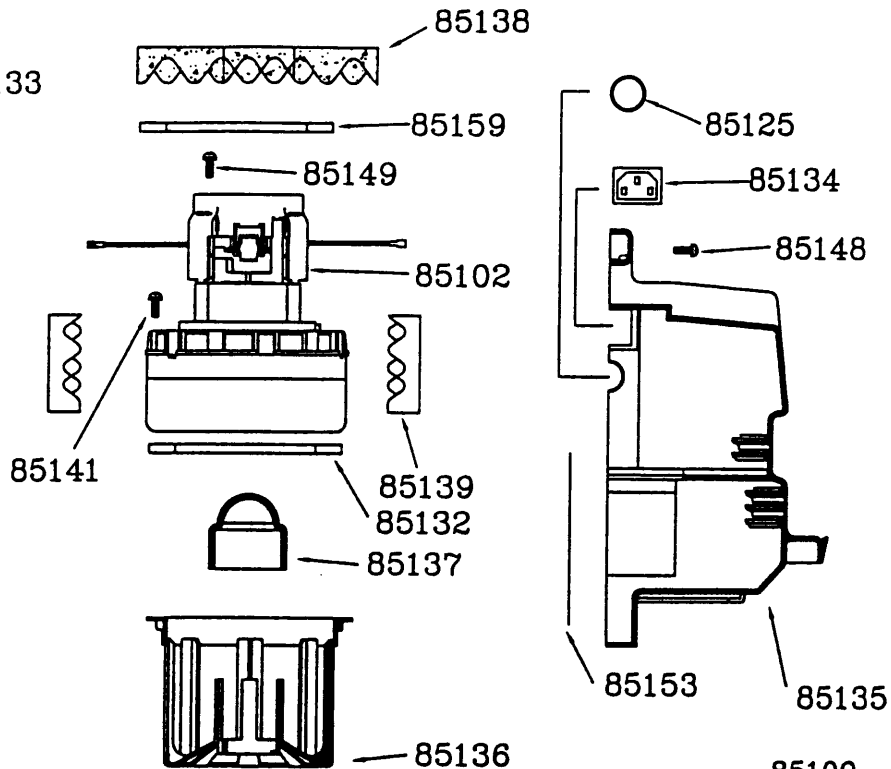
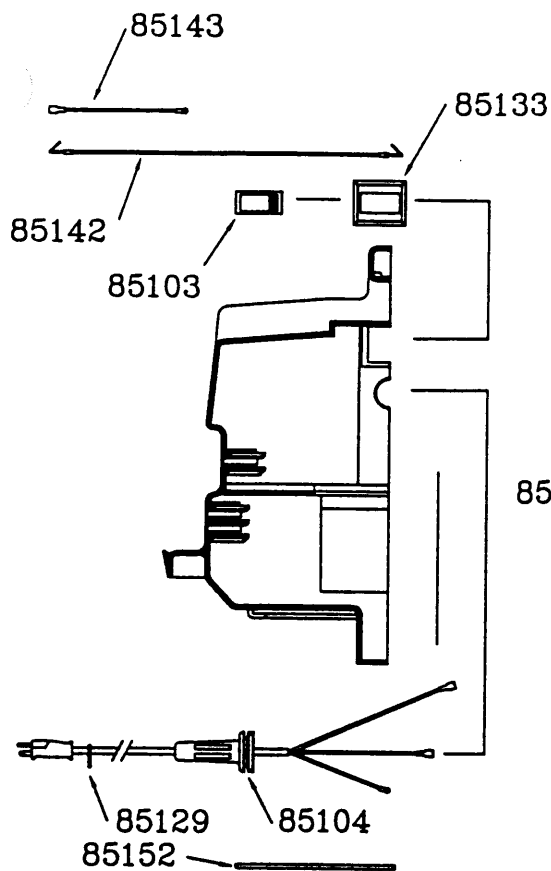

BETCO WET / DRY WD 18 DLY PARTS LIST 85008

ITEM	DESCRIPTION	QTY REQ
85102	MOTOR SMALL BI-PASS	1
85103	ROCKER SWITCH	1
85104	CORD ASSEMBLY 16/3 X 50'	1
85109	18 GAL TANK ASS'Y FOR DOLLY	1
85110	DOLLY ASSEMBLY	1
85112	3" CASTERS	2
85113	10" WHEEL	2
85114	DRAIN HOSE PLUG ASSEMBLY	1
85115	DRAIN HOSE	1
85116	HOSE CLIP	1
85117	TANK CLAMP	2
85118	INLET DEFLECTOR	1
85120	1/4 -20 NUT	3
85121	1/4 LOCKWASHER	3
85122	CASTER SOCKET	2
85123	NYLON WASHER	2
85124	AXLE END CAPS	2
85125	DOME PLUG	1
85126	TENSION WASHER	2
85127	1/2" RIVET	1
85128	BRASS WASHER	1
85129	CORD GRIP	1
85131	#10 X 3/8 PHS HI-LO	4
85132	UNIVERSAL MOTOR GASKET	1
85133	SWITCH PLATE	1
85134	POWER OUTLET PLUG	1
85135	MOTOR HOUSING	2
85136	FILTER CAGE LARGE	1
85137	FLOAT SHUT OFF	1
85138	TOP FOAM DISK	1
85139	LOWER ACCOUSTIC FOAM	8
85141	#10-16 X 1 PHS	2
85142	BLACK WIRE ASSEMBLY	1
85143	GROUND WIRE ASSEMBLY	1
85145	HOSE COUPLING	1
85146	1 1/2 HOSE CUFF	1
85147	HOSE CUFF 1 1/2 TO 1 1/4	1
85148	#8 X 3/4 PHS HI-LO	12
85149	#10-32 X 3/8 PHS - GROUND	2
85151	FILTER GASKET	1
85152	JOGGER RING	1
85153	HOUSING GASKET	1
85154	DRAIN HOSE CLAMP	1
85155	1/4 X 3/4 CARRIAGE BOLT	3
85156	1 1/2 VACUUM HOSE	1
85159	UPPER MOTOR GASKET	1
85202	VACUUM HOSE ASSEMBLY	1
85203	WET FILTER	1
85204	LARGE DRY FILTER	1
OPTIONS		
85208	FILTER HEPA LARGE	1
85157	CLAMP HEPA FILTER	1
85206	CLEAN-AIR FILTER BAG (10 PAK)	1

Wet/Dry Vacuums

Operator's Manual



WD3	Item #85002
WD5	Item #85004
WD12	Item #85005
WD12DLY	Item #85006
WD18	Item #85007
WD18DLY	Item #85008

Better Resources. Better Results.
BETCO[®]

**Operator Manual - WD3, WD5, WD12, WD12DLY, WD18, WD18DLY
Wet/Dry Vacuums**

INTRODUCTION

This manual will help you get the most from your Betco Wet Dry Vacuum. Read it thoroughly before operating.

The Betco Vacuum is intended for commercial use.

PARTS & SERVICE:

Contact your **BETCO AUTHORIZED DISTRIBUTOR** for repair parts or service. Please specify the **Model & Serial Number** when discussing your machine.

NAME PLATE:

The **Model & Serial Number** of your machine is located on the **Name Plate** on the vacuum head assembly. This information is often needed when ordering repair parts for the machine.

IMPORTANT SAFETY INSTRUCTIONS

When using an electrical appliance, basic precautions should always be followed, including the following:
Read all instructions before using.

! WARNING!

To reduce risk of fire, electric shock, or injury:

- * Do not leave the machine when it is plugged in. Unplug the unit from the outlet when not in use & before servicing.
- * To avoid electric shock, do not expose machine to rain. Store indoors.
- * Do not allow to be used as a toy. Close attention is necessary when used by or near children.
- * Use only as described in this manual. Use only manufacturer's recommended attachments.
- * Do not use with damaged cord or plug. If machine is not working as it should return it to a service center for inspection.

- * Do not pull or carry by cord, use cord as a handle, close a door on a cord, or pull cord around sharp edges or corners. Do not run machine over cord. Keep cord away from heated surfaces.
 - * Do not unplug by pulling on cord. To unplug, grasp the plug, not the cord.
 - * Do not handle plug or machine with wet hands.
 - * Do not put any foreign object into openings. Do not use with any opening blocked; keep free of dust, lint, hair, & anything that may reduce airflow.
 - * Keep hair, loose clothing, fingers, & all parts of body away from openings & moving parts.
 - * Turn off all controls before unplugging.
 - * Do not use in or around flammable or combustible liquids such as gasoline or use in areas where they may be present.
 - * Connect to a properly grounded outlet only. See grounding instructions.
-

GROUNDING INSTRUCTIONS

This machine must be grounded. If it should electrically malfunction, grounding provides a path of least resistance for electric current to reduce the risk of electric shock. This machine is equipped with a cord having an equipment-grounding conductor & grounding plug. The plug must be plugged into an appropriate outlet that is properly installed & grounded in accordance with all local codes & ordinances.

! DANGER!

Improper connection of the equipment-grounding conductor can result in a risk of electric shock. Check with a qualified electrician or service person if you are in doubt as to whether the outlet is properly grounded. Do not modify the plug provided with the machine. If plug will not fit the outlet, have a proper outlet installed by a qualified electrician.

Replace the plug if the grounding pin is damaged or broken.

Extension cords connected to this machine should be 12 gauge, 3-wire cords with 3-prong plugs & outlets. DO NOT use extension cords more than 50 feet long.

PREPARING THE MACHINE FOR OPERATION

! WARNING!

This machine contains moving parts. To reduce the risk of injury, always unplug the power cord before servicing.

Unwrap the power cord completely & plug into a properly grounded outlet.

For wet pick up install head gasket and ring.

For dry pickup install cloth filter bag. (Optional paper bag and/or cartridge may also be used.)

Attach screw on swivel hose connector and hose to tank inlet.

Select proper floor tool. Wet squeegee for wet pick up. Dry floor tool for dry pick up. Install selected tool on 2-bend wand.

Turn switch located on vacuum head to on position.

You are now ready to begin your cleaning task.

AFTER USE

Unplug the power cord, starting from the machine wrap the power cord onto the head assembly.

Completely empty tank of water and debris. Flush tank and dry with a clean towel.

Wipe vacuum head assembly with damp towel.

Wipe the entire machine with a clean, damp cloth.

Inspect the machine & all accessories for damage. Perform any required maintenance or repairs before storage.

Store the machine in a clean, dry place.