



E12300-00  
E10280-00



# PREDATOR SERIES

21", 24"  
Propane Burnishers



Operator and Parts  
Manual

# TABLE OF CONTENTS

Carbon Monoxide Warning .....	3
Safety .....	4
Tank Use and Storage .....	5
Starting and Stopping the Honda Engine .....	5
Operator Preparation.....	6
Belt Tensioning .....	7
Pad Change Methods .....	8
Pad Driver Removal .....	8
Major Assemblies .....	9
Handle Bar .....	10 - 11
Lower Handle Support .....	12 - 13
Regulator Assembly.....	14 - 15
110V Starter Button .....	14 - 15
Honda Engine Assembly .....	16 - 17
Deck Assembly .....	18 - 19
Belt Drive System.....	20 - 21
Pad Drive System.....	22 - 23
Centrifugal Clutch Assembly .....	24 - 25
Parts List.....	26 - 27
Electrical Schematic.....	28
Engine Maintenance.....	29
Troubleshooting .....	30
Warranty .....	32



## **WARNING - CARBON MONOXIDE LETHAL EXHAUST GAS - MUST READ THIS! -**



### **Never Run The Engine In A Closed Building Or Confined Area**

Exhaust gases contain poisonous carbon monoxide. Carbon monoxide is odorless, colorless, and can cause death if inhaled.

### **Carbon Monoxide Poisoning Symptoms**

Train your employees to know the warning signs of carbon monoxide poisoning.

Mild carbon monoxide poisoning may cause any of the following:  
Headache, drowsiness, faintness, poor coordination, nausea, and vomiting.  
Turn the engine off and immediately get to fresh air if you have any of these symptoms.

Do not run the machine until it is given an emissions test and repairs made by an authorized distributor.

- Local emissions testing is available at a fork-lift service department.

Moderate or severe carbon monoxide poisoning causes confusion, unconsciousness, chest pain, shortness of breath, and coma. Thus, most victims are not able to move themselves and must be rescued. Severe poisoning is often fatal.

Carbon monoxide is dangerous because a person may not recognize drowsiness as a symptom of poisoning. Consequently, someone with mild poisoning can go to sleep and continue to breathe the carbon monoxide until severe poisoning or death occurs. Some people with long-standing, mild carbon monoxide poisoning caused by furnaces or heaters may mistake their symptoms for other conditions, such as the flu or other viral infections.

### **Carbon Monoxide Detectors**

CO detectors are a must for safe operation of your equipment. Various types are available. A “CO” carbon monoxide detector detects carbon monoxide before it reaches dangerous levels. Detectors are a must for those who run propane powered equipment. The CO Detector is for everyone’s protection against Carbon Monoxide Poisoning.

- Carbon Monoxide Detector - Passive
  - Effective for 30 days after package has been opened.
  - Write the date opened on the detector.
  - Mount with self-adhesive strip on the machine handle.
  - Train machine operator to check detector regularly.
  - If the **orange disk changes to gray or black** - your Carbon Monoxide Levels are at a Dangerous Level.
  - If the **orange disk changes to gray or black** you must **turn your buffer off immediately** and return it to your nearest authorized distributor for an emissions test.
  - **Do Not Restart** the machine until the emissions have been checked and corrected.
  - This is for your protection as well as your customers. CO detectors are a must for safe operation and maximum efficiency of your equipment.
  - For replacement CO detectors, contact your distributor. Ask for the **carbon monoxide detector, part# E12426.**
- Carbon Monoxide Detector - battery operated with alarm
  - Available from various sources

# SAFETY

## Important Safety Information

All LPG (Liquid Propane Gas) powered engines, including this engine, produce Carbon Monoxide (CO). It is a **Lethal Poison** that is colorless, odorless, tasteless, and non-irritating gas. You must read “Danger: Lethal Exhaust Gas” information below.

Keep hands, feet, and loose clothing away from all moving parts while the machine is in operation. The exhaust system gets very hot so keep hands, clothing and any items that can burn away from the engine, engine manifold, and muffler.

These machines are tough and durable, however do not abuse the machine. With proper care and maintenance this unit will give you years of trouble free operation.

## Carbon Monoxide Safety Information

Engine exhaust gases contain poisonous carbon monoxide. Carbon monoxide is odorless, colorless, tasteless, and can cause death if inhaled. Failure to provide proper venting of CO, failure to properly maintain the engine, or failure to properly train personnel of the dangers and warning signs of carbon monoxide exposure may result in **Serious Injury Or Death** to the operator and others in the area.

- Any equipment with the potential to produce carbon monoxide presents a significant hazard when used indoors. They must be used with great caution. Opening a door or window, or running an exhaust fan will not necessarily supply adequate ventilation. Avoid inhaling exhaust fumes and never run the engine in a closed building or confined area without proper ventilation.
- Do not allow engine to run unattended.
- If you have any indication that the engine is not running properly, immediately shut the machine off and have it checked over and repaired by qualified maintenance personnel.
- Workers should be trained to recognize the hazards of carbon monoxide and the early symptoms of carbon monoxide poisoning.
- A carbon monoxide detector and alarm should be available to alert workers of emissions.
- Have a carbon monoxide detector attached to machine handle or have machine operator wear a carbon monoxide detector. (See carbon monoxide detector page).
- Use only as described in this manual.
- Use only manufacturer’s recommended components.
- Maintenance and repairs must be done by qualified personnel.
- Only trained operators should be allowed to operate propane powered floor machines.
- If the machine is not working properly, have it serviced by an authorized service center.
- Install fuel cylinder in a well ventilated place.
- Be aware of possible leaks of propane gas if odor is present.
- If the machine is stored inside a building, remove the fuel cylinder and store properly outside.
- Secure fuel cylinders when being transported.
- If tank is left attached to the machine then valve should be OFF.
- Never store fuel cylinders in a vehicle, building, or area where they may be exposed to high temperature.
- Do not operate the machine with any openings blocked.
- Keep openings free of debris that may reduce airflow.
- Remove fuel cylinder and disconnect battery before servicing.

# TANK USE AND STORAGE

## Propane Tank Use

We use the Worthington gas cylinders designed for vapor withdrawal. The fuel lock offs, regulators, and engines are also designed for vapor withdrawal.

- We recommend that you use the OPD (Overflow Protection Device) vapor withdrawal type cylinder. These style tanks have a triangle shaped valve handle.
- Do not overfill - the best gauge is a scale - never allow tank to weigh over **36 pounds** for an aluminum tank and **43 pounds** for a steel tank.
- Connect fuel cylinder to machine in a well ventilated place.
- Be aware of possible leaks of propane gas if odor is present.
- Use propane tanks designed for vertical use only.

## Propane Tank Storage

- Store tanks outside in a well-ventilated area.
- Never store fuel cylinders in a vehicle, building, or area where they may be exposed to high temperature.
- If the machine is stored inside a building, remove the fuel cylinder and store properly outside.
- Secure fuel cylinders when being transported.
- If tank is left attached to the machine then valve should be OFF.
- Store tanks in the upright position (valves up).
- Be aware of possible leaks of propane gas if odor is present.

# STARTING AND STOPPING THE HONDA ENGINE

## Starting The Honda Engine

The Honda engine is equipped with a 110 volt starter and a push button start.

1. Place propane tank into handle assembly and close propane tank strap clamp to secure tank.
2. Attach propane hose coupling and fully tighten.
3. Tilt machine back so that pad is off the floor.
4. Open propane tank valve (turn counterclockwise) and check for any leaks.
5. Plug cord into starter connection and plug into wall outlet.
6. Push and hold throttle cable in the "Choke" position.
7. Push the red start button and hold until engine starts. Do not crank for more than 20 seconds at one time. Wait at least one minute between tries when cranking. See troubleshooting guide if the engine does not start after several tries.
8. After engine starts, set throttle to a slow operating speed until the motor warms up. Engine speed may be increased after 3 to 5 minutes.
9. Unplug the cord from the wall and the machine and return the cord to its storage position.
10. Check for frost on the regulator and fuel line. Frost will indicate that the machine is drawing liquid propane from an overfilled or incorrect tank.

## Stopping The Honda Engine

1. Turn propane tank valve to the closed position (turn clockwise) and allow the engine to continue running until it runs out of fuel.

# OPERATOR PREPARATION

## Before Starting the Machine

### **Read the Owner's Manual and the Engine Operation Manual.**

Your machine is shipped ready for operation; however there is no fuel in the tank. When having the tank filled, you must make sure the tank is never over-filled.

- The best way to do this is to tell the filling station to weigh the tank full. On an aluminum tank, it should weigh no more than **36 pounds** and on a steel tank no more than **43 pounds**. (See more information at "Tank Storage and Maintenance" page.)

Adjust the handle for comfortable operation. Remove hairpin cotter pins from clevis pins, remove pins, and adjust to the hole alignment that gives the most comfortable height. Replace clevis pins and hairpin cotter pins. Tighten nuts and bolts if needed.

Make sure pad is not torn, pad is well attached and centering device is tightened.

**Check Oil Level:** Starting the engine without the proper amount of oil will cause severe engine damage. Always keep the engine oil level between the full and add marks on the dipstick. Do not loosen oil fill cap or remove dipstick while engine is running.

- Park your burnisher on a level surface.
- Turn the oil fill cap counter clockwise and then lift from the fill tube.
- Wipe the dip stick clean and push it back into the oil fill tube until the cap seats and then withdraw it to check: the oil level. (Do not screw cap on to check oil). Add if necessary. If the oil level is low, add API Class SM oil having a SAE viscosity grade appropriate for the expected temperatures as indicated in the Operators Manual (Usually a HD30 or 10W30).
- Important Note: **Do Not Overfill**
- Replace oil cap.

Inspect fuel hoses and fittings for wear and leaks. Have all worn hoses and leaks repaired before operating.

Look and listen for exhaust leaks. Have all leaks repaired before operating.

Check the carburetor filter and air filter for debris. Clean and replace if necessary.

Connect fuel hose to tank by screwing the hose fitting to tank. You must tighten all the way down to make fuel connection. Turn tank knob slowly until you hear the flow of fuel into fuel system.

# BELT TENSIONING

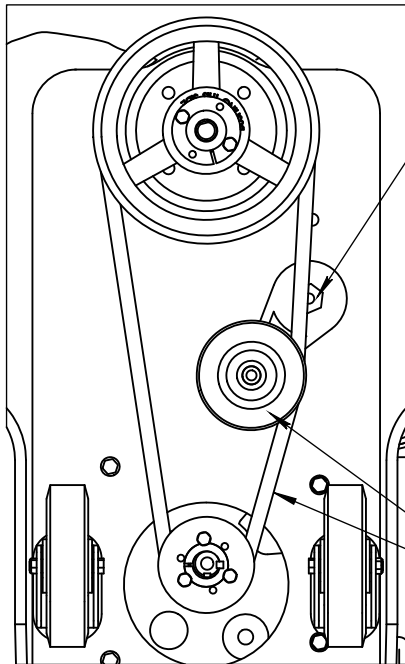

Use 15/16" socket with extension to tighten tensioner in direction of arrow.

Test tension by pushing or pulling on belt or belt tensioner. With proper belt tension the pulley on the belt tensioner should only move about 1".

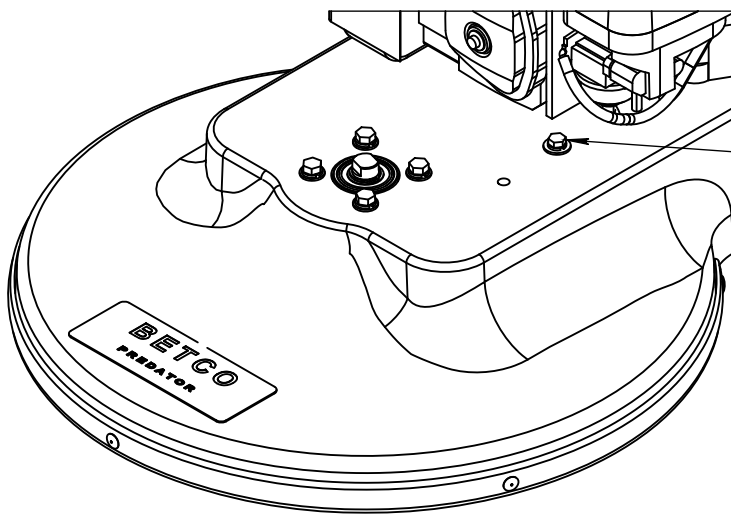

Use 9/16" wrench to tighten tensioner bolt.

1. Tilt Machine back onto rear caster or tilt machine onto its side with the **air filter up**.
2. Remove the pad driver using 3/4" open ended wrench. (See pad changing & pad driver removal section)
3. On top of the deck use a 9/16" wrench to loosen the belt tensioner bolt.
4. Using a 15/16" socket and extension, fully tighten the belt tensioner from the underside of the deck.
5. Back off fully tightened belt tensioner about 10-15 degrees about 1 mark or about 2 inches at the end of the socket handle. (Note: There are 5 marks on the side of the tensioner. Each mark is equal to about 15 degrees and this leaves about 60 degrees of tightness.)
6. While holding the belt tensioner in position tighten the tensioner bolt on top of the deck.  
**TIGHTEN SECURELY!**
7. Hand test the tensioner by pushing and pulling on the tensioner. The belt should be tight and the arm should move about 10-15 degrees about 1".

# PAD CHANGE METHODS

## Caution: Muffler May Be Hot!

1. Tilt the machine back on its caster.
2. Unscrew the pad center threaded hold.
3. Remove the pad from the pad driver.
4. Get new, correct size pad for burnisher.
5. Center new pad on pad driver.
6. Screw in the pad center threaded hold until tight.
7. Place machine upright.
8. Set front of machine on floor to ensure pad driver grips pad before starting.

1. Tilt the machine so the **air filter is up**.
2. Unscrew the pad center threaded hold.
3. Remove the pad from the pad driver.
4. Get new, correct size pad for burnisher.
5. Center new pad on pad driver.
6. Screw in the pad center threaded hold until tight.
7. Place machine upright.
8. Set front of machine on floor to ensure pad driver grips pad before starting.

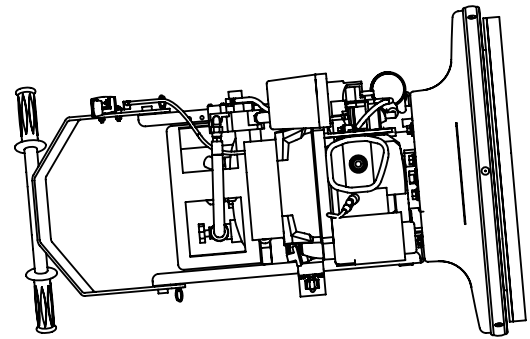
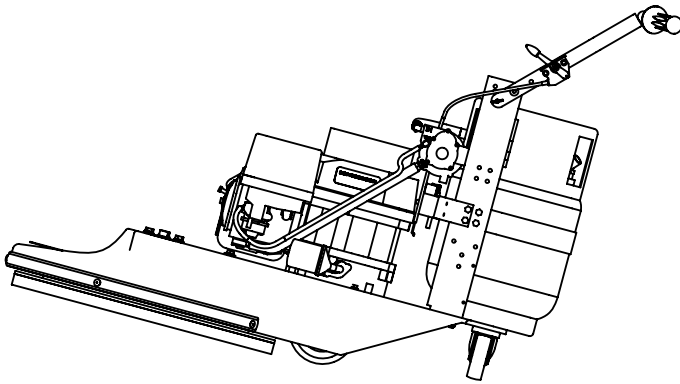

---

# PAD DRIVER REMOVAL

Spin the pad driver the direction of the arrow to loosen.

Use a 3/4" open end wrench as shown to hold pad drive shaft while spinning the pad driver.

When screwing on the pad driver spin pad driver in opposite direction of arrow. Snug pad driver without wrench. When the machine is started the contact between the floor and the pad will tighten the pad driver completely.

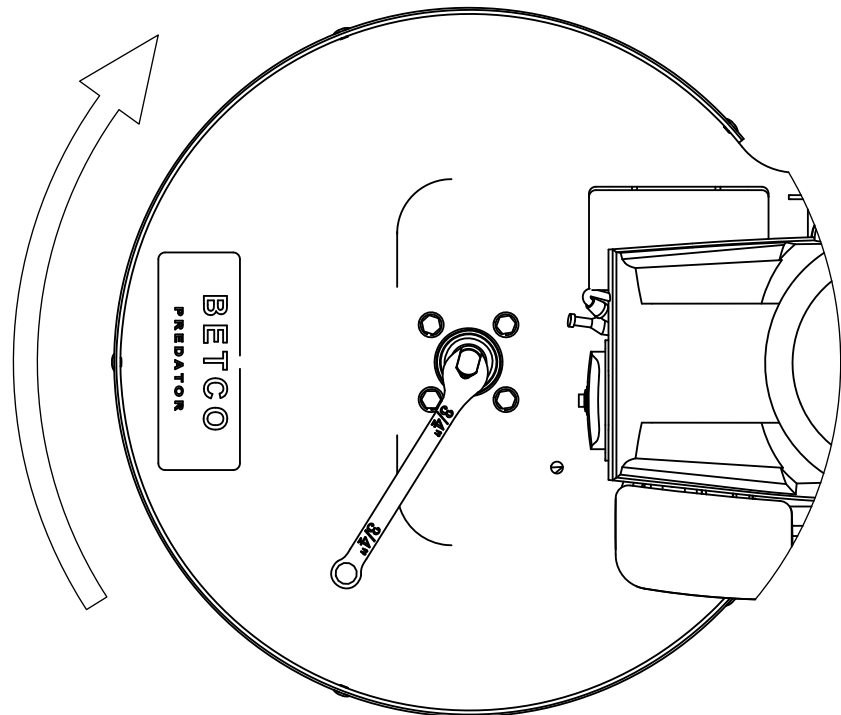



# MAJOR ASSEMBLIES

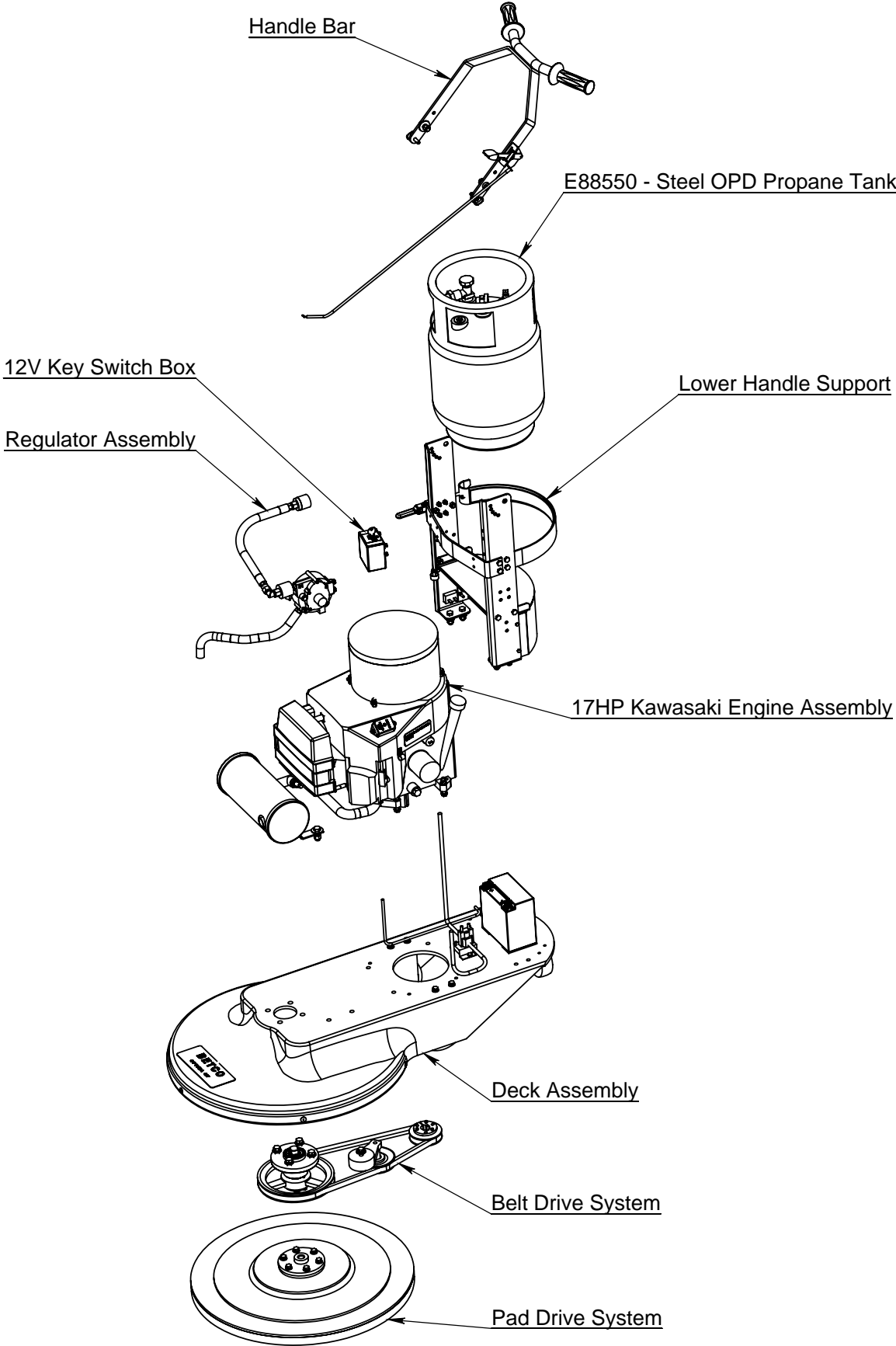

# HANDLE BAR

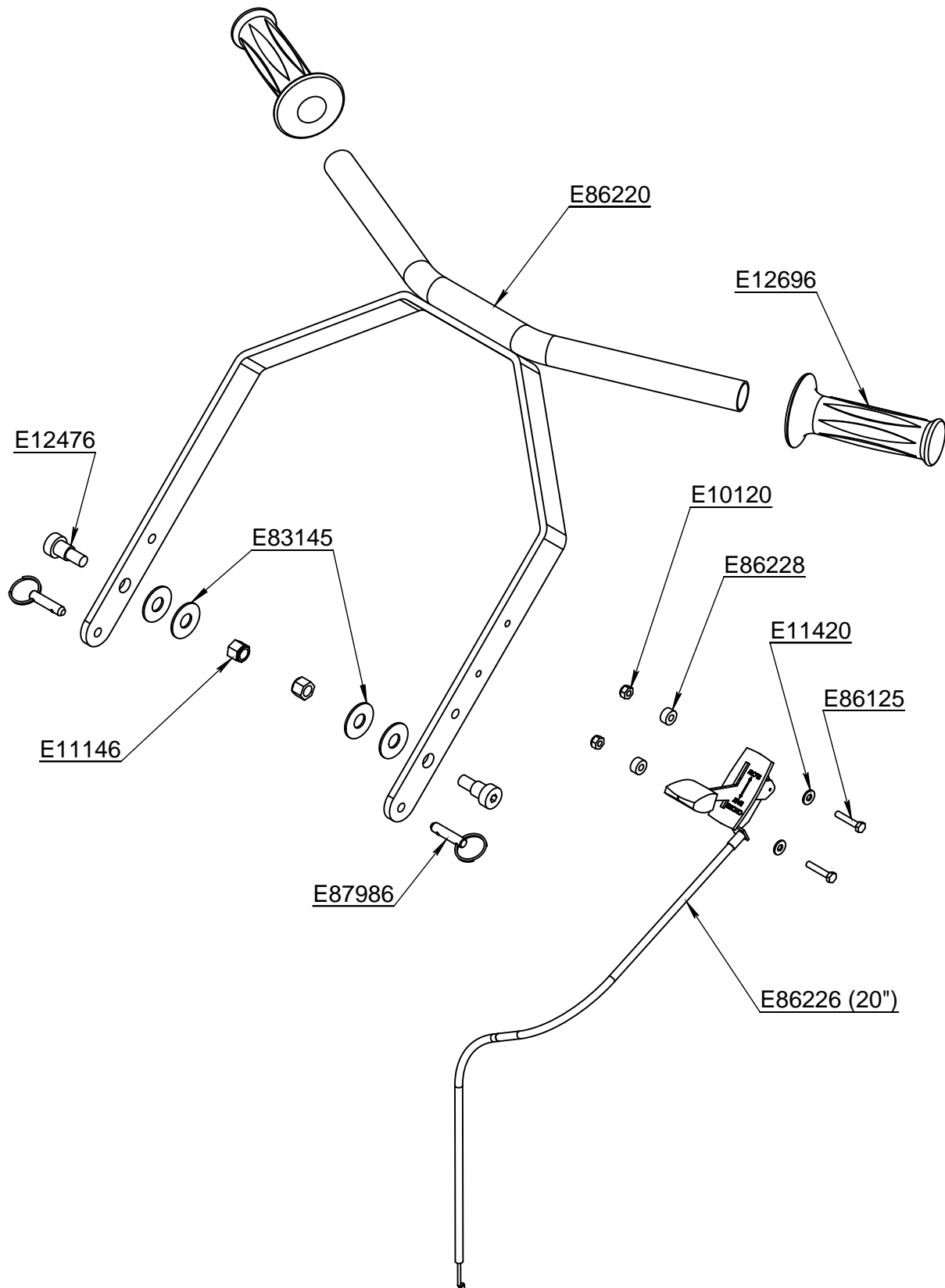

PART NUMBER	Description	QTY.
E10120	Nut, #10-32, Nylon Lock, Grade 5, Zinc	2
E11146	Nut, 3/8"-16, Nylon Lock, Grade 5, Zinc	2
E11420	Washer, #10 SAE, Zinc	2
E12476	Screw, Shoulder 1/2" x 1/2" Socket Head	2
E12696	Hand Grip	2
E83145	Washer, Nylon 1/2" ID X 1.25" OD	4
E86125	Screw, #10-32 x 1.000 Hex Head, Zinc	2
E86220	Handle Bar Weldment	1
E86226	Honda Throttle Cable 20" L	1
E86228	Spacer, #10 ID x 1/2" OD x 1/4" Long, Black Nylon	2
E87986	Pin, 5/16" x 3/4" Detent with Ring	2

Note: Not available for purchase assembled.

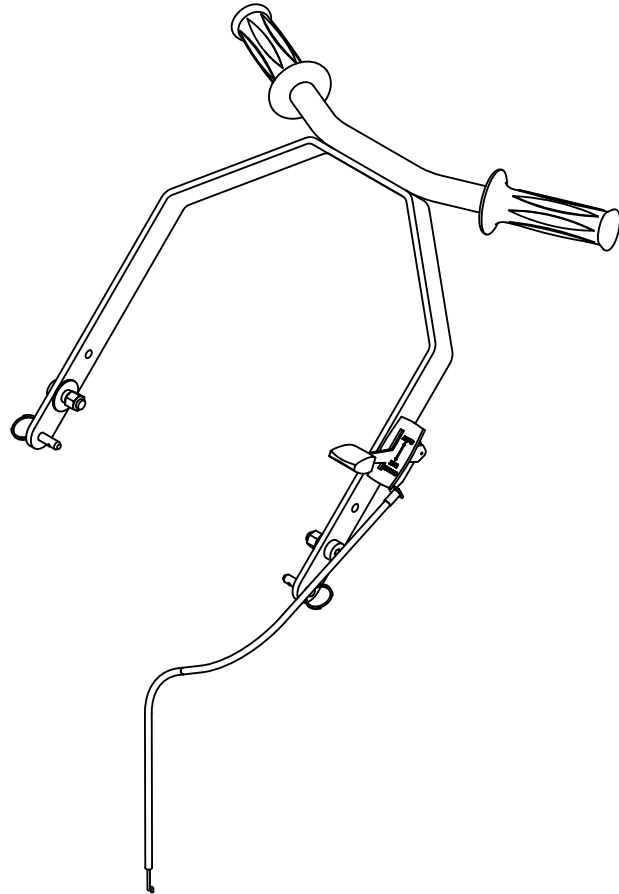

# LOWER HANDLE SUPPORT

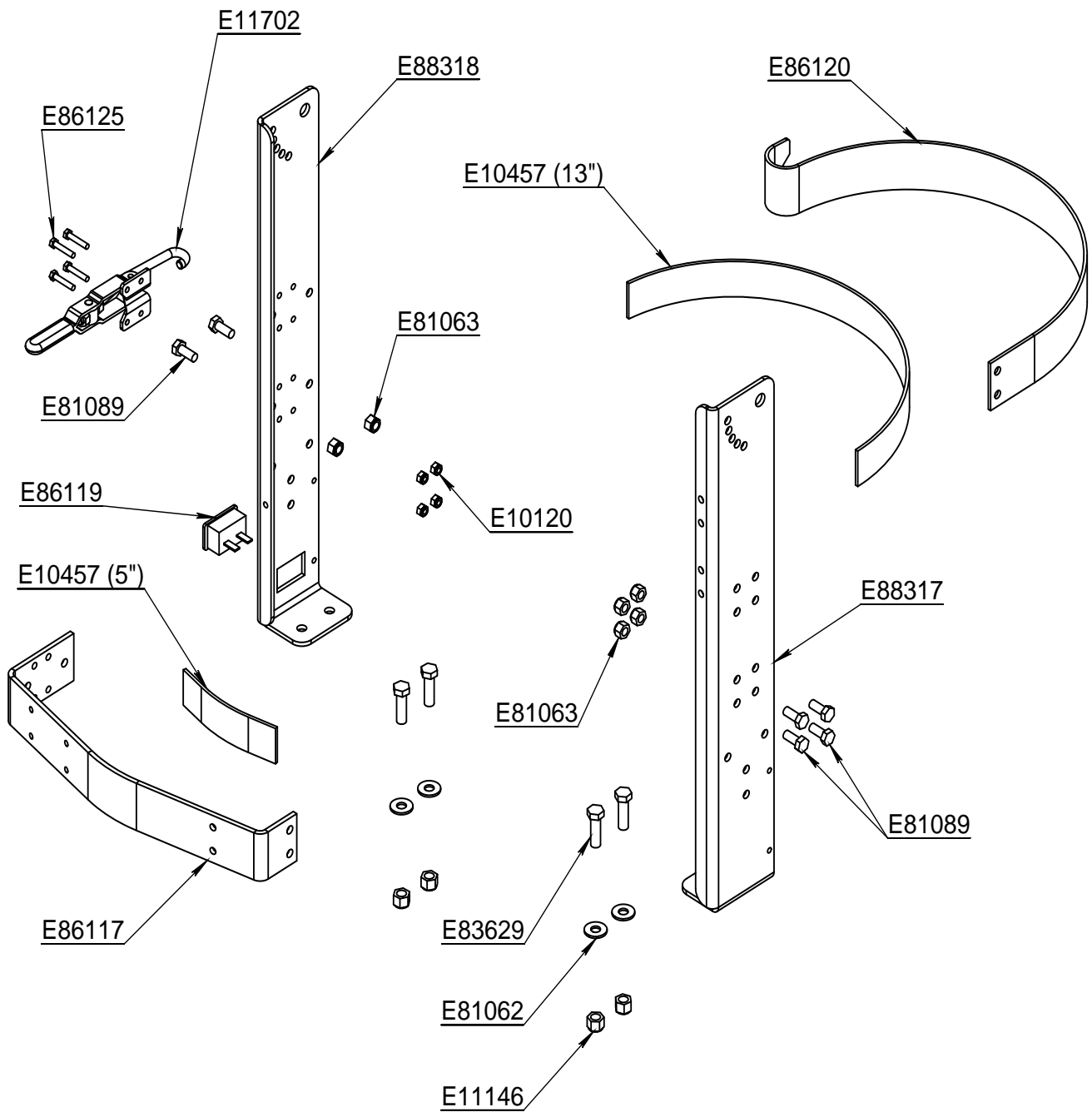

PART NUMBER	Description	QTY.
E10120	Nut, #10-32, Nylon Lock, Grade 5, Zinc	4
E10457	Felt, 1.500 W x 0.125 Thick, Adhesive Back	2
E11146	Nut, 3/8"-16, Nylon Lock, Grade 5, Zinc	4
E11702	Propane Tank Strap Latch	1
E81062	Washer, 5/16" USS, Zinc	4
E81063	Nut, 5/16"-18, Nylon Lock, Grade 5, Zinc	6
E81089	Screw, 5/16"-18 x 0.750 Hex Head, Grade 5, Zinc	6
E83629	Screw, 3/8"-16 x 1.250 Hex Head, Grade 5, Zinc	4
E86117	Propane Tank Strap Front	1
E86119	Hour Meter, SenDEC 5-80V	1
E86120	Propane Tank Strap Back	1
E86125	Screw, #10-32 x 1.000 Hex Head, Zinc	4
E88317	Lower Handle Leg Left	1
E88318	Lower Handle Leg Right	1

Note: Not available for purchase assembled.

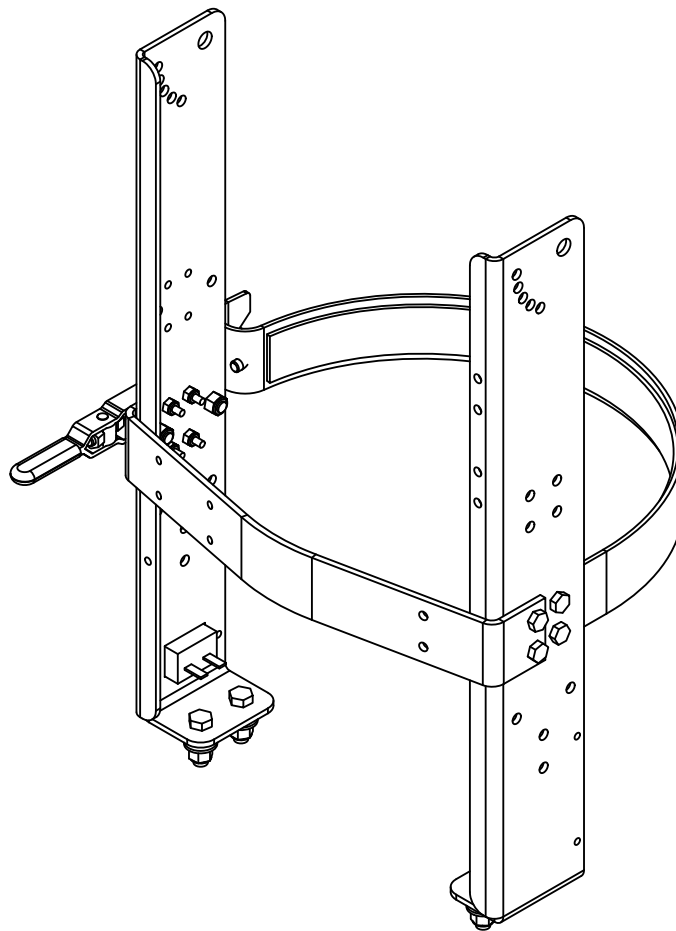

# REGULATOR ASSEMBLY

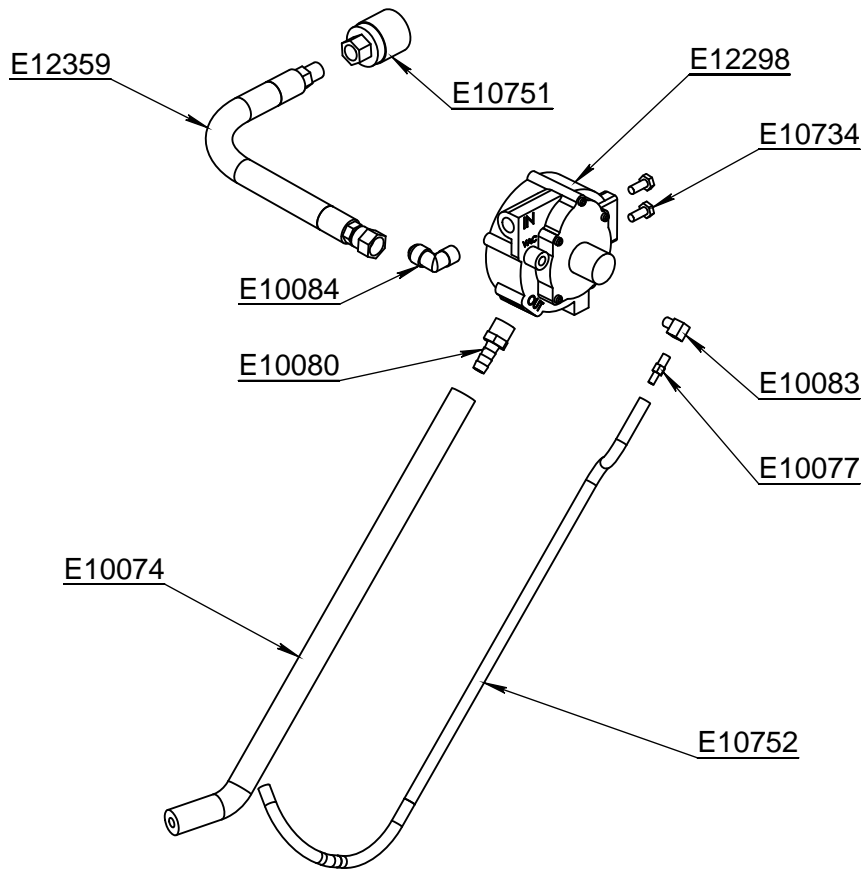

---

# 110V STARTER BUTTON

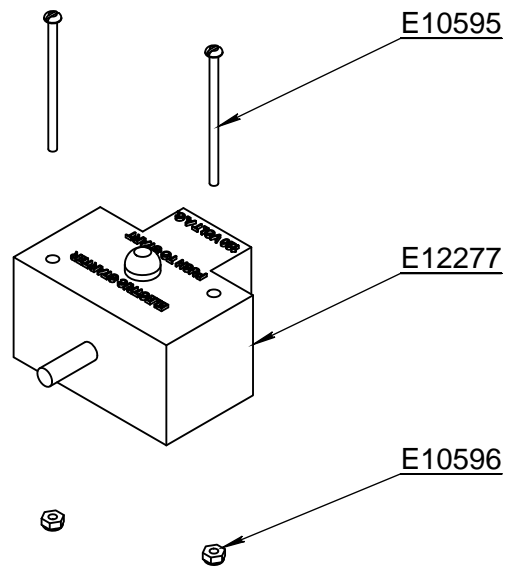

PART NUMBER	Description	QTY.
E10074	Honda Lola Fuel Hose	1
E10077	Fitting, 1/8" MNPT x 1/8" Barb, Hose Barb	1
E10080	Fitting, 3/8 MNPT x 3/8 Barb, Hose Barb, Brass	1
E10083	Fitting, 1/8" MNPT x 1/8" FNPT, Street Elbow, Brass	1
E10084	Fitting, 3/8 MNPT x 3/8 MJIC, 90 Elbow, Brass	1
E10708	Cable Tie, Nylon AF525	3
E10734	Screw, 1/4"-20 x 0.625 Hex Head, Grade 5, Zinc	2
E10751	Propane Tank Coupling 7141F	1
E10752	Vacuum Hose	1
E12298	Fuel Regulator 60B	1
E12359	Fuel Hose	1

Note: Not available for purchase assembled.

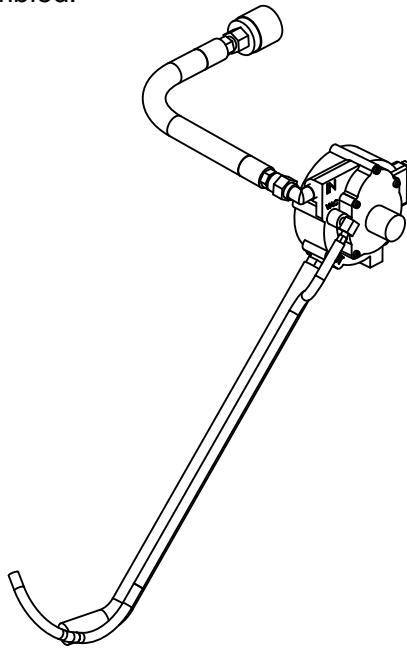

PART NUMBER	Description	QTY.
E10595	Screw #6-32 x 2.500 Pan Head, Slot, Zinc	2
E10596	Nut, #6-32, Nylon Lock, Grade 5, Zinc	2
E12277	Starter Button	1

Note: Starter button and Starter come as one part and are attached by the wire.

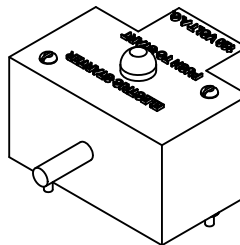

# HONDA ENGINE ASSEMBLY

- E10022 -- Ignition Coil
- E10963 -- Spark Plug, NGK
- E11464 -- Head Gasket
- E12411 -- Electric Cord
- E12426 -- CO Detector  
Badge
- E12440 -- Oil Level Switch

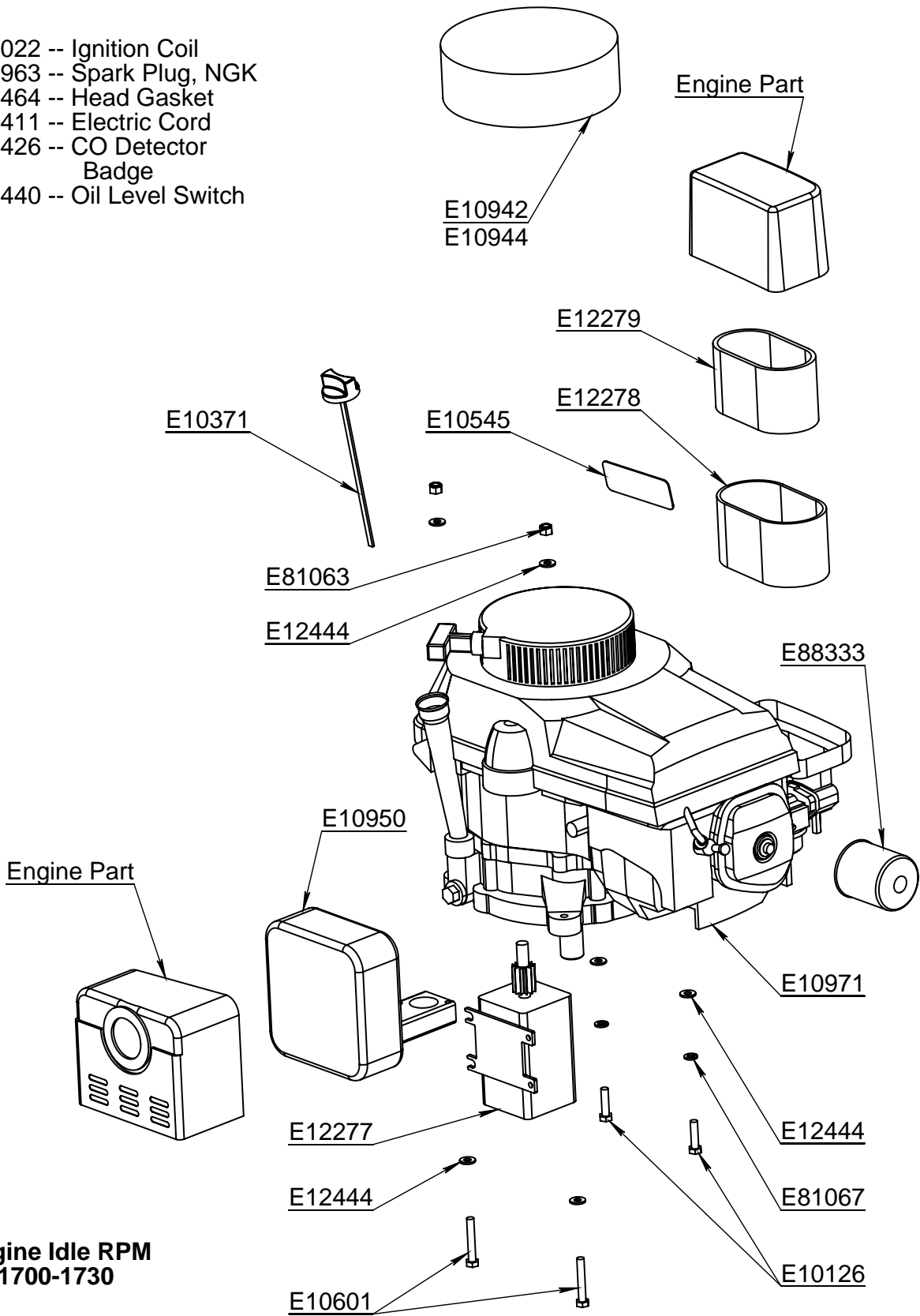



<b>PART NUMBER</b>	<b>Description</b>	<b>QTY.</b>
E10022	Voltage Regulator	1
E10126	Screw, 5/16"-24 x 1.250 Hex Head Grade 5, Zinc	2
E10371	Honda Oil Dipstick	1
E10544	Decal, Centrifugal Clutch	1
E10545	Decal, Read Owner's Manual	1
E10601	Screw, 5/16"-18 x 2.000 Hex Head, Grade 5, Zinc	2
E10942	Honda Intake Filter, 13HP	1
E10950	Honda Muffler	1
E10963	Spark Plug, NGK	1
E10971	LP Ready Honda Engine, 13HP	1
E11464	Gasket, Engine Head	1
E12277	Honda 110V Starter	1
E12278	Honda Foam Air Filter	1
E12279	Honda Paper Air Filter	2
E12411	Electric Cord	1
E12426	CO Detector Badge	1
E12440	Oil Level Switch	1
E12444	Washer, 5/16" SAE, Zinc	6
E81063	Nut, 5/16"-18, Nylon Lock, Grade 5, Zinc	2
E81067	Washer, 5/16" Split Lock, Zinc	2
E88333	Oil Filter, Honda	1

Note: Starter button and Starter come as one part and are attached by the wire.

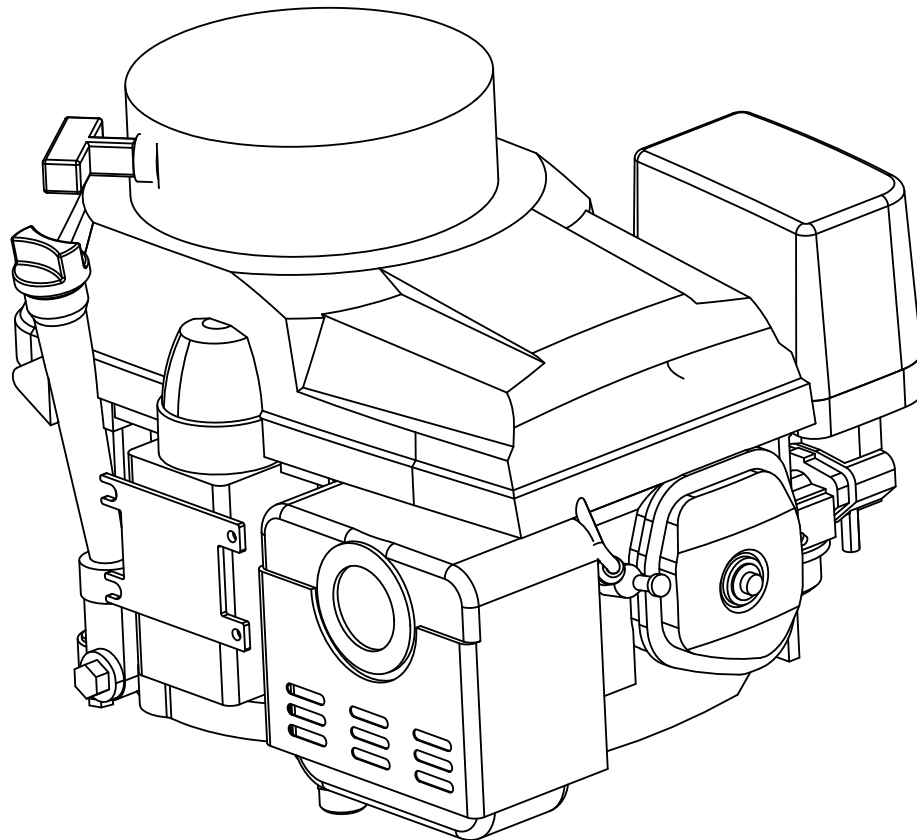

# DECK ASSEMBLY

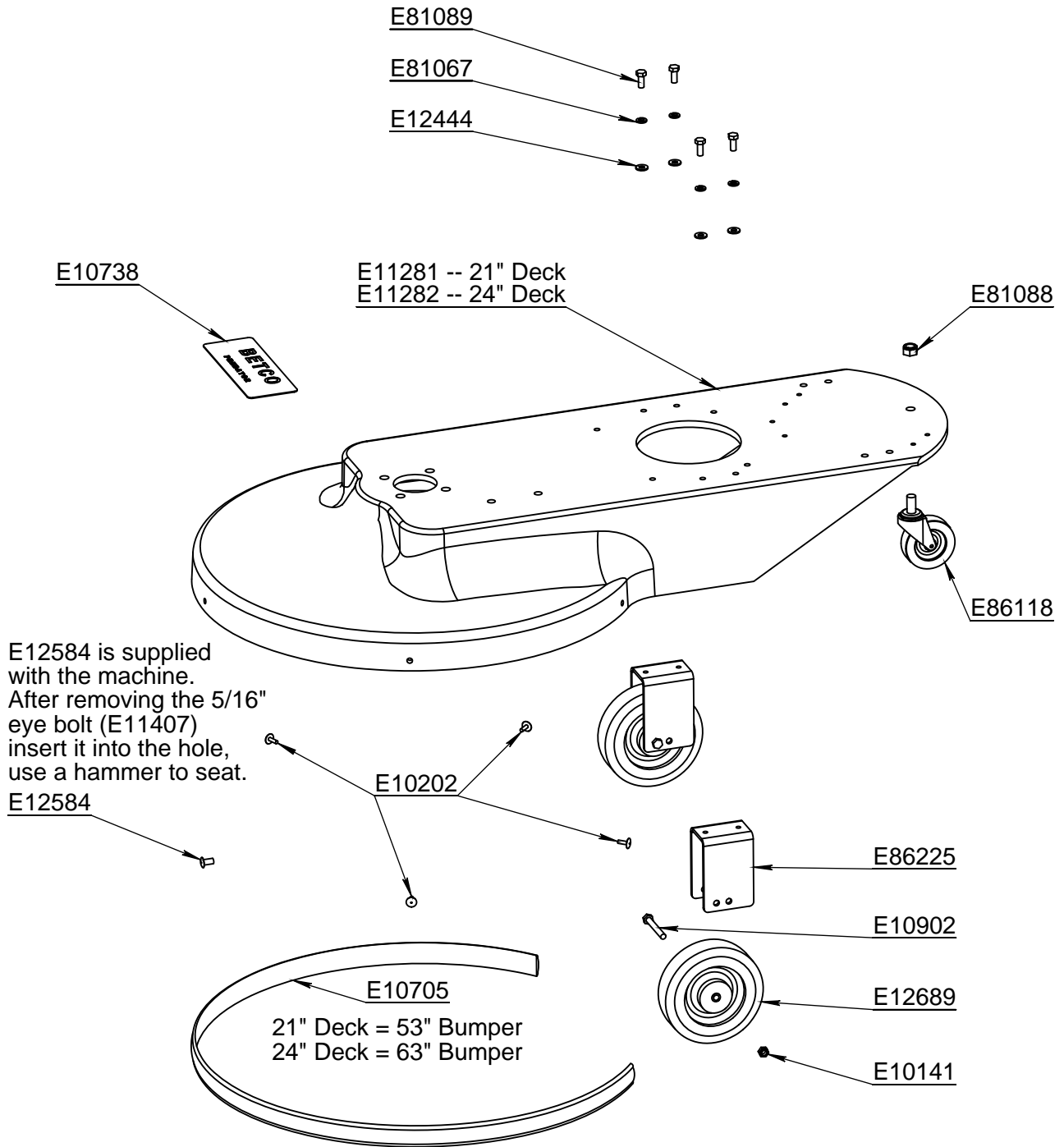

PART NUMBER	Description	QTY.
E10141	Nut, 5/16"-18, Slim, Nylon Lock, Grade 5, Zinc	2
E10202	Rivet, 3/16" OD x 0.700" L with 0.600" Head	4
E10705	Bumper, Red (21" Deck = 53", 24" Deck = 63", 28" Deck = 75")	1
E10738	Decal, BETCO Predator	1
E10902	Screw, 5/16"-18 x 2.500 Hex Head, Grade 5, Zinc	2
E11281	Deck, 21" Aluminum Casting Duracoat 21	1
E11282	Deck, 24" Aluminum Casting Duracoat 24	1
E11407	Screw, 5/16"-18 x 3.250 Eyebolt with Nut, Zinc	1
E12444	Washer, 5/16" SAE, Zinc	4
E12584	Rivet, 5/16" Drive (Hammer In)	1
E12689	Wheel, 6" with Sealed Ball Bearings, Non-Marking	2
E81067	Washer, 5/16" Split Lock, Zinc	4
E81088	Nut, 1/2"-13, Slim, Nylon Lock, Grade 5, Zinc	1
E81089	Screw, 5/16"-18 x 0.750 Hex Head, Grade 5, Zinc	4
E86118	Swivel Caster 1/2"-13 x 1.000" Stud	1
E86225	Wheel Bracket	2

Note: Not available for purchase assembled.

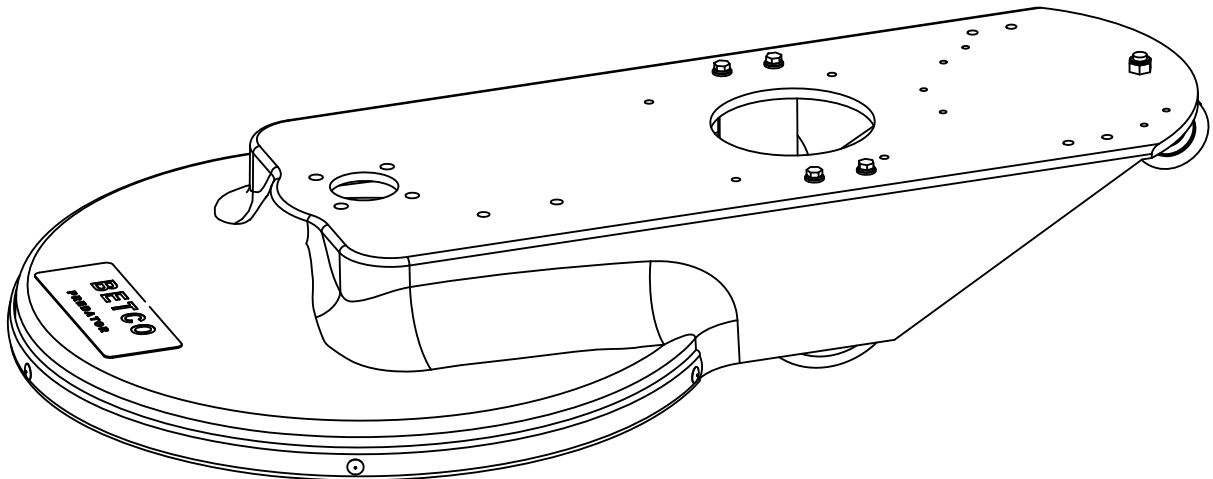

# BELT DRIVE SYSTEM

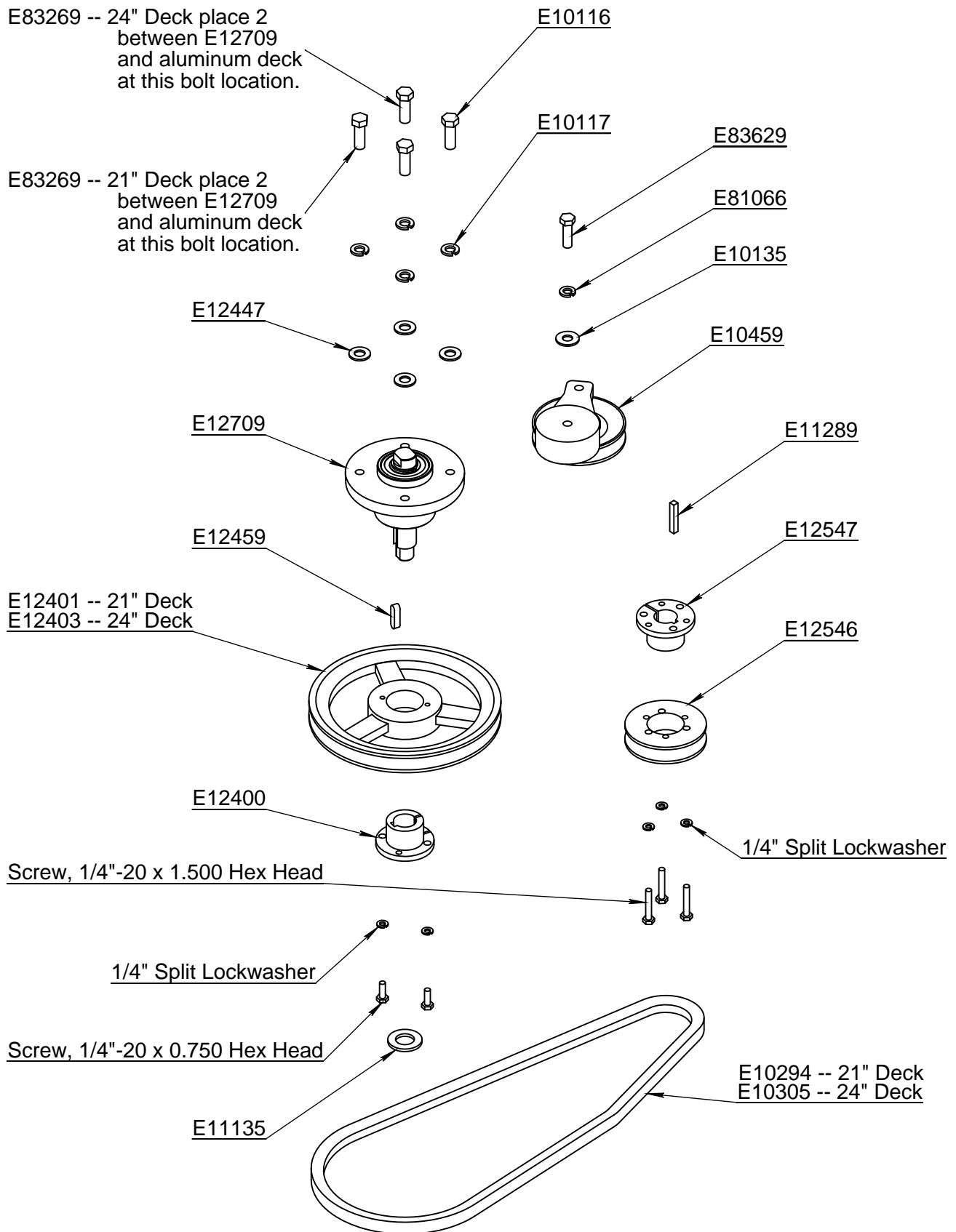

PART NUMBER	Description	QTY.
Bushing Part 1	1/4" Split Lockwasher	3
Bushing Part 2	1/4" Split Lockwasher	2
Bushing Part 3	Screw, 1/4"-20 x 0.750 Hex Head	2
Bushing Part 4	Screw, 1/4"-20 x 1.500 Hex Head	3
E10116	Screw, 7/16"-14 x 1.250 Hex Head, Grade 5, Zinc	4
E10117	Washer, 7/16" Split Lock, Zinc	4
E10135	Washer, 3/8" USS, Zinc	1
E10294	Belt, BX41 V-Belt, 41"	1
E10305	Belt, BX49 V-Belt, 49"	1
E10459	Belt Tensioner	1
E11135	Washer, 3/4" SAE, Zinc	1
E11289	Key 1/4" x 1/4" x 1.500"	1
E12400	Bushing, QT 25mm Taper Lock	1
E12401	Pulley BK75H - 7.50 OD	1
E12403	Pulley, BK85H - 8.25 OD	1
E12447	Washer, 7/16" SAE, Zinc	4
E12459	Key 8mm x 7mm x 30mm	1
E12546	Engine Pulley 1B34SH - 3.75 OD	1
E12547	Bushing, SH 1.00" QD Taper Lock	1
E12709	Pad Driver Alum Bearing Assembly with Shaft	1
E81066	Washer, 3/8" Split Lock, Zinc	1
E83269	Washer, 1/2" ID x 0.020" T, Spring	2
E83629	Screw, 3/8"-16 x 1.250 Hex Head, Grade 5, Zinc	1

Note: Not available for purchase assembled.

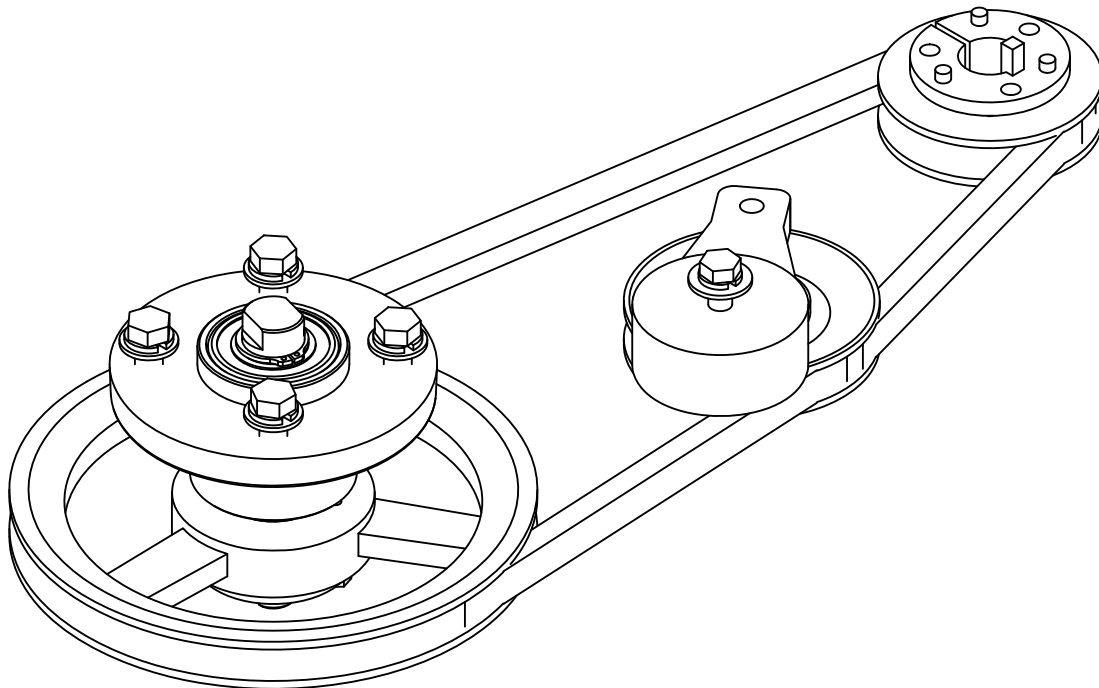

# PAD DRIVE SYSTEM

PE50028 -- 21" Pad Drive Assembly  
PE50027 -- 24" Pad Drive Assembly

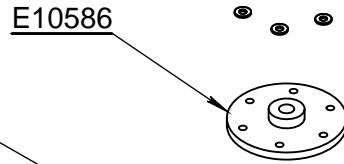
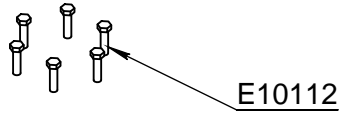

E10250 -- 21" Pad Driver  
E10251 -- 24" Pad Driver

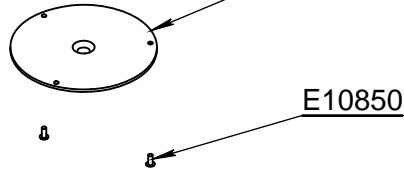
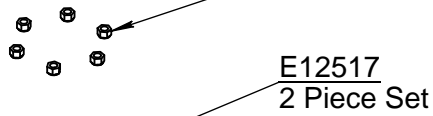
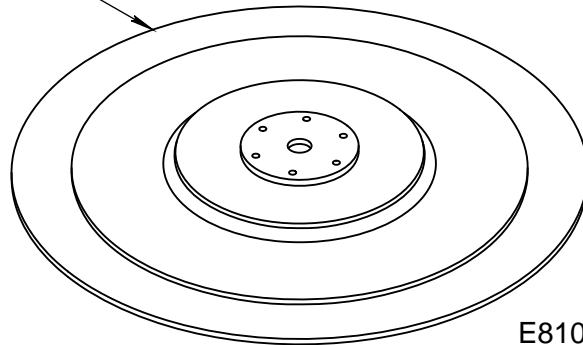

84621 -- 21" Pad  
84624 -- 24" Pad

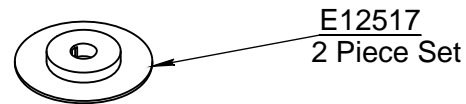
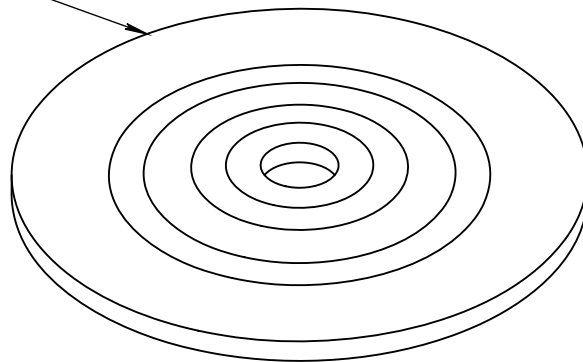

PART NUMBER	Description	QTY.
84621	Pad, 21" Hi-Shine Light Burnish Pad, 5/Case	1
84624	Pad, 24" Hi-Shine Light Burnish Pad, 5/Case	1
E10112	Screw, 5/16"-18 x 1.250 Hex Head Grade 5, Zinc	6
E10250	21" Pad Driver	1
E10251	24" Pad Driver	1
E10586	3/4" Pad Driver Shaft Coupling	1
E10850	Rivet, 3/16" OD x 15/16" L with 3/8" Head	3
E12444	Washer, 5/16" SAE, Zinc	6
E12517	Pad Lock, Center Lok II ® RH Set Black	2
E81063	Nut, 5/16"-18, Nylon Lock, Grade 5, Zinc	6
E81067	Washer, 5/16" Split Lock, Zinc	6
PE50027	Pad Drive Assembly 24" Without Pad	1
PE50028	Pad Drive Assembly 21" Without Pad	1

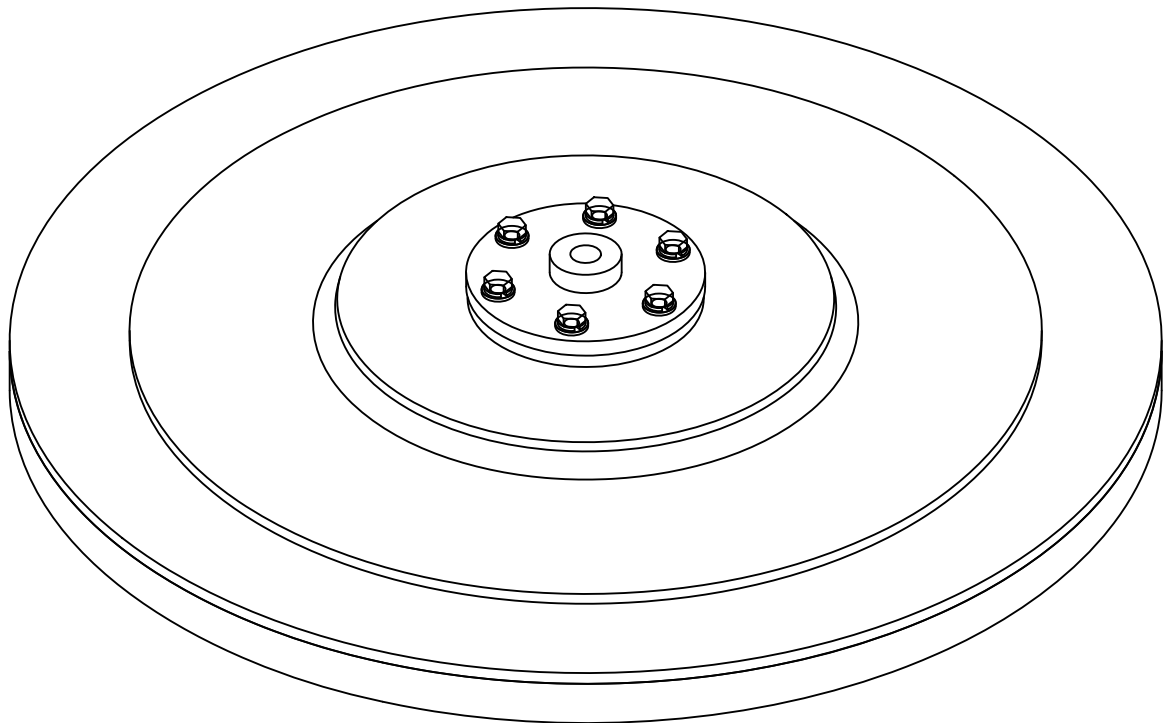

# CENTRIFUGAL CLUTCH ASSEMBLY

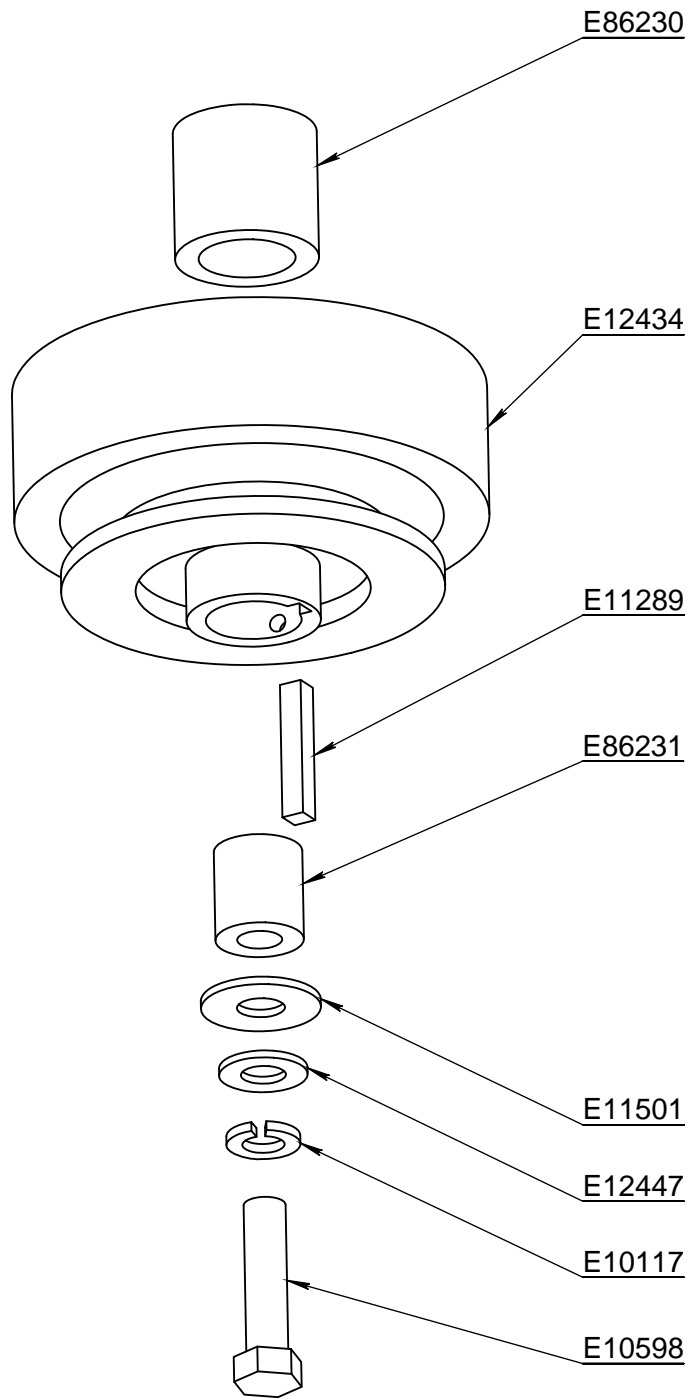

E86230 is installed to align the belt drive section of the clutch to the pad driver pulley belt drive section.

Remove and discard set screws from clutch before installing.

Install key after pushing clutch onto the engine drive shaft and aligning keyways.

**Engine Idle RPM  
1700-1730**

E11501 should tighten onto the lip of the clutch. E86231 should be just inside the lip of the drive shaft hole.



PART NUMBER	Description	QTY.
E10117	Washer, 7/16" Split Lock, Zinc	1
E10598	Screw 7/16"-20 x 1.750 Hex Head, Grade 5, Zinc	1
E11289	Key 1/4" x 1/4" x 1.500"	1
E11501	Washer, 7/16" USS, Zinc	1
E12434	Clutch, Centrifugal 1750 RPM 4" Dia.	1
E12447	Washer, 7/16" SAE, Zinc	1
E86230	Spacer, Clutch Burn Honda Top 1.000 ID x 1.125 L	1
E86231	Spacer, Clutch Burn Honda Bottom 0.469 ID x 0.922 OD x 0.696 L	1

Note: Not available for purchase assembled.

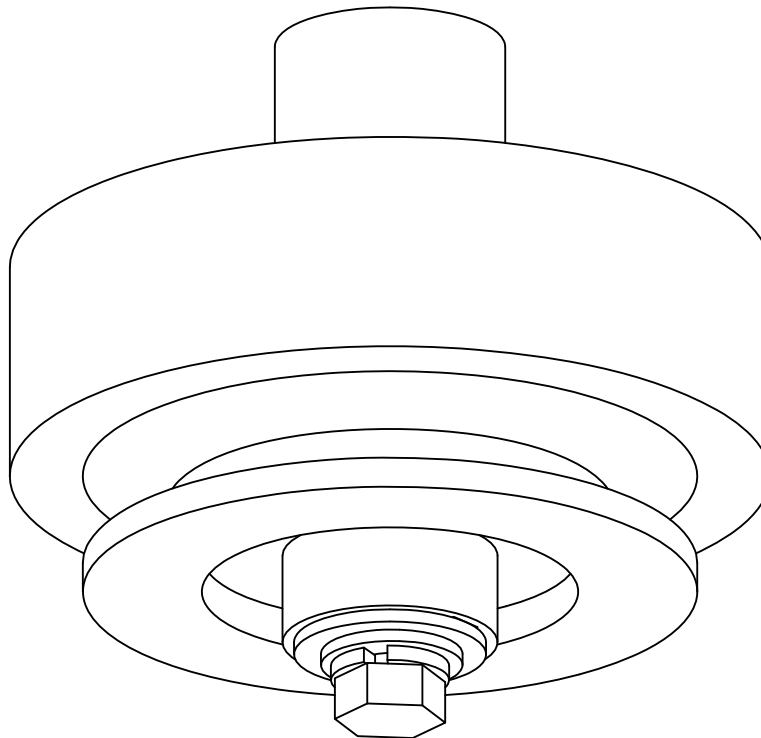

# PARTS LIST

Page	Part #	Description
23	84621	Pad, 21" Hi-Shine Light Burnish Pad 5/Case
23	84624	Pad, 24" Hi-Shine Light Burnish Pad 5/Case
23	84627	Pad, 27" Hi-Shine Light Burnish Pad 5/Case
17	E10022	Voltage Regulator
15	E10074	Hose, 6 LOLA Fuel Line 9.5mm ID x 16mm OD x 25" L
15	E10077	Fitting, 1/8 MNPT x 1/8 Barb, Brass
15	E10080	Fitting, 3/8 MNPT x 3/8 Barb, Hose Barb, Brass
15	E10083	Fitting, 1/8" MNPT x 1/8" FNPT, Street Elbow, Brass
15	E10084	Fitting, 3/8 MNPT x 3/8 MJIC, 90 Elbow, Brass
23	E10112	Screw, 5/16"-18 x 1.250, Hex, Grade 5, Zinc
21	E10116	Screw, 7/16"-14 x 1.250, Hex, Grade 5, Zinc
21,25	E10117	Washer, 7/16" Split Lock, Zinc
"11,13	E10120	Nut, #10-32 Nylon Lock, Zinc
17	E10126	Screw, 5/16"-24 x 1.250 Hex Head, Grade 5, Zinc
	E10128	Wire, 14 Gauge, Red
21	E10135	Washer, 3/8" USS, Zinc
19	E10141	Nut, 5/16"-18 Nylon Lock Slim, Zinc
19	E10202	Rivet, 3/16" OD x 0.700" L with 0.600" Head
11	E10212	Washer, 5/16" Flat Push On, Zinc
	E10235	Connector, Ring 16-14 x 3/8" Ring
23	E10250	Pad Driver, 21" Flex Lok Assembly
23	E10251	Pad Driver, 24" Flex Lok Assembly
23	E10252	Pad Driver, 27" Flex Lok Assembly
21	E10294	Belt, BX41 V-Belt, 41"
21	E10305	Belt, BX49 V-Belt, 49"
11	E10328	Pin, 5/16" x 0.875 Clevis With Cotter Pin Hole, Zinc
17	E10371	Honda Oil Dipstick
11	E10385	Lanyard, 3/64" cable 6" L
13	E10457	Felt, 1.500 W x 0.150 Thick, Adhesive Back
21	E10459	Belt Tensioner, Propane Burnisher FS0111
	E10544	Decal, Clutch

Page	Part #	Description
17	E10545	Decal, Read Owner's Manual
	E10553	Wire, 14 Gauge Black
	E10557	Loom, 1/4"
23	E10586	Coupling, 3/4" Pad Driver Shaft
15	E10595	Screw, #6-32 x 2.500 Pan Head, Zinc
15	E10596	Nut, #6-32 Nylon Locknut, Zinc
25	E10598	Screw, 7/16"-20 x 1.750 Hex Head, Grade 5, Zinc
17	E10601	Screw, 5/16"-18 x 2.000 Hex, Grade 5, Zinc
19	E10705	Bumper, Red [Model 21 (53"), 24 (63"), 28 (75")]
15	E10708	Cable Tie, Nylon AF525
15	E10734	Screw, 1/4"-20 x 0.625 Hex, Grade 5, Zinc
19	E10738	Decal, BETCO Predator
15	E10751	Propane Tank Coupling 7141F
15	E10752	Hose, 5/32" ID Vacuum
23	E10850	Rivet, 3/16" OD x 0.938" L with 0.375" Head
19	E10902	Screw, 5/16"-18 x 2.500 Hex, Grade 5, Zinc
17	E10942	Intake Filter Honda 13HP
17	E10944	Intake Filter Honda 11HP
17	E10950	Honda Muffler
17	E10963	Spark Plug, NGK
17	E10967	Engine, GXV340 Honda 11HP Gasoline Ready
17	E10971	Engine, GXV390 Honda 13HP Gasoline Ready
21	E11135	Washer, 3/4" SAE, Zinc
21	E11195	Washer, 3/8" Split Lock, Zinc
19	E11281	Deck, 21" Aluminum Casting Duracoat 21
19	E11282	Deck, 24" Aluminum Casting Duracoat 24
21,25	E11289	Key, 1/4" x 1/4" x 1.500"
	E11353	Clamp, Large Tube
19	E11407	Screw, 5/16"-18 x 3.250 Eyebolt with Nut, Zinc
11	E11420	Washer, #10 SAE, Zinc
17	E11464	Gasket, Engine Head

Page	Part #	Description
11	E11645	Pin, Hairpin Cotter #1
	E11663	Decal, Steel Propane Tank Fill Limit 43 lbs.
	E11664	Decal, Aluminum Propane Tank Fill Limit 36 lbs.
13	E11702	Propane Tank Strap Latch
19	E11840	Deck, 28" Aluminum Casting Duracoat 28
	E12254	Connector, Female Quick Disconnect
15,17	E12277	Honda 110V Starter
17	E12278	Honda Foam Air Filter
17	E12279	Honda Paper Air Filter
15	E12298	Fuel Regulator Model 60B
15	E12359	Propane Tank Hose 1/4" MNPT - 3/8 MJIC 16.50" L
21	E12400	Bushing, QT 25mm Taper Lock
21	E12401	Pulley, BK75H - 7.50 OD
21	E12403	Pulley, BK85H - 8.25 OD
17	E12411	Electric Cord
17	E12426	CO Detector Badge
25	E12434	Clutch, Centrifugal 1750 RPM 4" Dia.
17	E12440	Oil Level Switch
17,19,23	E12444	Washer, 5/16" SAE, Zinc
21,25	E12447	Washer, 7/16" SAE, Zinc
21	E12459	Key, 8mm x 7mm x 30mm
11	E12476	Screw, 1/2" x 1/2" Shoulder Screw 5/16"-18
23	E12517	Pad Lock, Center Lok II® RH Set Black
21	E12546	Pulley, 1B3.44 QD Sheave
21	E12547	Bushing, SH 1.00" QD Taper Lock
19	E12584	Rivet, 5/16" Drive (Hammer In)
19	E12689	Wheel, 6" with Sealed Ball Bearings Non-Marking
11	E12696	Hand grip
21	E12709	Pad Driver Alum Bearing Assembly with Shaft
11,13,25	E81062	Washer, 5/16" USS, Zinc
13,17,23	E81063	Nut, 5/16"-18 Nylon Lock, Zinc

Page	Part #	Description
17,19,23	E81067	Washer, 5/16" Split Lock, Zinc
11,13	E81076	Nut, 3/8"-16 Nylon Lock, Zinc
19	E81088	Nut, 1/2"-13 Slim, Nylon Lock, Zinc
13,19	E81089	Screw, 5/16"-18 X 0.750" Hex, Grade 5, Zinc
11	E83145	Washer, Nylon 1/2" ID X 1.25" OD
21	E83269	Washer, 1/2" ID X 0.020" T, Spring
13,21	E83629	Screw, 3/8"-16 x 1.250 Hex, Grade 5, Zinc
17	E85461	Oil Drain Hose Accessory
13	E86117	Propane Tank Strap Front
19	E86118	Swivel Caster 1/2"-13 x 1.000" Stud
13	E86119	Hour Meter, SenDEC 5-80V
13	E86120	Propane Tank Strap Back
11,13	E86125	Screw, #10-32 x 1.000 UNF Hex, Grade 5, Zinc
11	E86220	Handle Bar Weldment
19	E86225	Wheel Bracket
11	E86226	Cable, Honda Throttle Cable 20" L
11	E86228	Spacer, #10 ID x 1/2" OD x 1/4" Long, Black Nylon
25	E86230	Spacer, Clutch Burnisher Honda Top
25	E86231	Spacer, Clutch Burnisher Honda Bottom
13	E88317	Lower Handle Leg Left
13	E88318	Lower Handle Leg Right
17	E88333	Oil Filter, Honda
9	E88550	Steel OPD Propane Tank
23	EP50027	24" Pad Drive Assembly
23	EP50028	21" Pad Drive Assembly
17	EP50030	Engine, GXV390 Honda 13HP LP Ready
17	EP50031	Engine, GXV340 Honda 11HP LP Ready
23	EP50040	27" Pad Drive Assembly
11	EP50087	Pin & Lanyard Assembly (E010212, E010385, E010328)

# ELECTRICAL SCHEMATIC

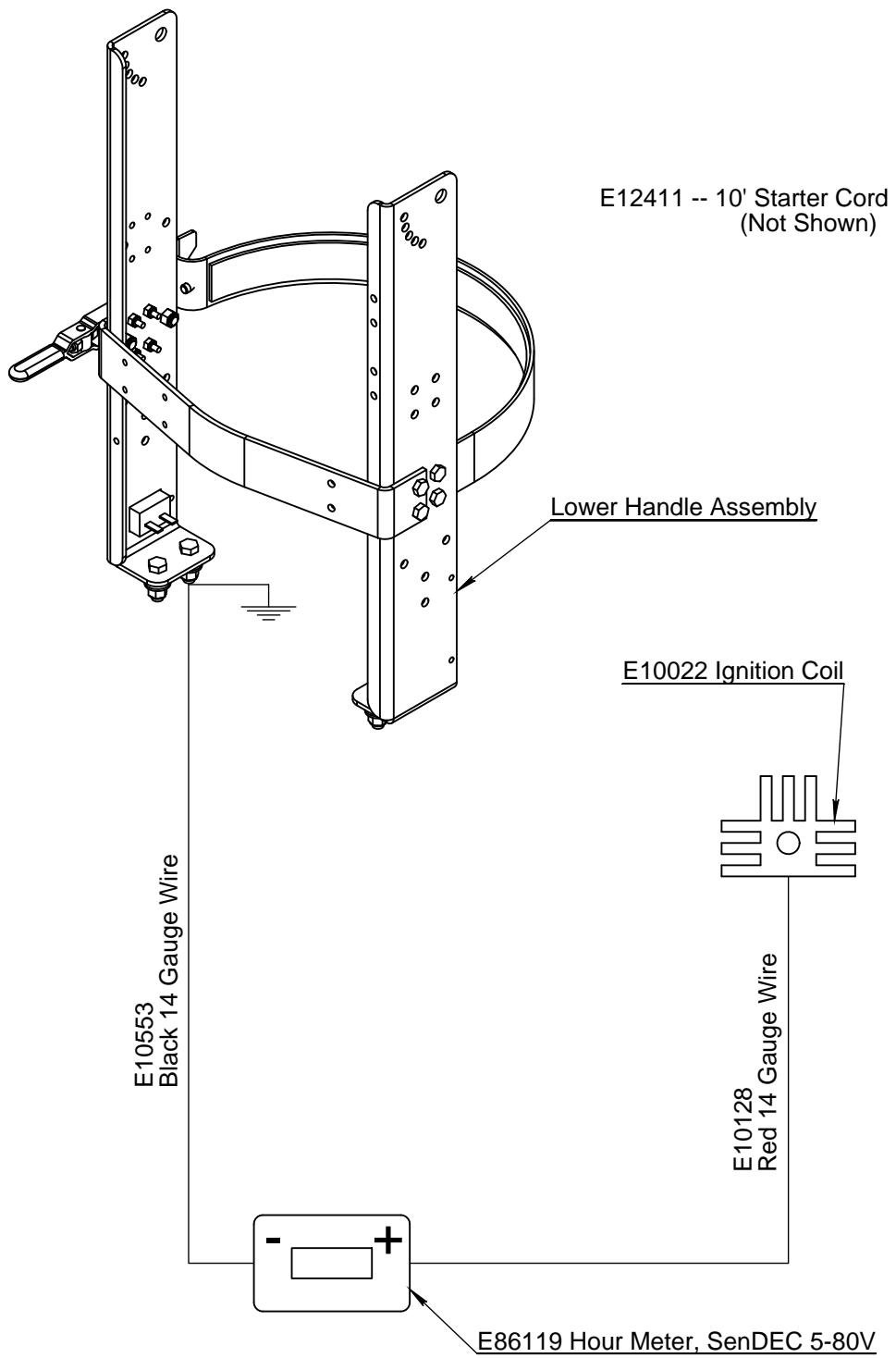

# ENGINE MAINTENANCE

## HONDA GXV340 11HP & GVX390 13HP

<b>PERIODIC MAINTENANCE</b> PLEASE REFER TO ENGINE OWNERS MANUAL FOR MORE INFORMATION	DAILY	EVERY 25 HOURS	EVERY 50 HOURS	EVERY 100 HOURS	EVERY 200 HOURS
Check engine oil level and add if needed	*				
Check and clean engine intake filter	*				
"General check for loose or lost nuts, screws, oil leakage, fuel hose connection, etc."	*				
Clean air cleaner foam element		*			
Clean air cleaner paper element		*			
Check belt tension		*			
Change engine oil			*		
"Clean dust and dirt from cylinder and cylinder head cooling fins"				*	
Tighten nuts and screws				*	
Clean and regap spark plugs				*	
Replace air cleaner paper element					*
Replace air cleaner foam element					*
Replace spark plugs					*
Check and adjust valve clearance					*
Clean combustion chamber					*
Clean and lap valve seating surface					*

**IMPORTANT NOTES:**

- 1) Change engine oil and filter after first 8 hours of operation.
- 2) Maintenance should be done by qualified personnel only.

# TROUBLESHOOTING

PROBLEM	CAUSE	POSSIBLE SOLUTION
Engine will not turn over	Loose wire or bad connection	Check wires and connections
	Bad electrical component	Replace bad component
	Fuel system problem	Refer to engine owner's manual and read IMPORTANT below
Engine turns over, but will not start	Propane tank shut off valve in off position	Open propane tank shut off valve completely
	Propane tank empty	Fill propane tank
	Fuel system problem	Refer to engine owner's manual and read IMPORTANT below
	Engine problem	Refer to engine owner's manual and read IMPORTANT below
Hard to start	Throttle lever in slow position	Push throttle lever to fast position
	Throttle lever not in choke position	Push throttle lever to choke position
	Propane tank shut off valve not fully open	Open propane tank shut off valve completely
	Some type of engine problem	Refer to engine owner's manual and read IMPORTANT below
Engine stops suddenly and will not restart	Out of propane	Replace propane tank with full propane tank
	Low oil	Add oil
Engine overheats	Intake air filter is dirty	Remove air intake filter and clean
	Incorrect oil level	Add or remove oil to achieve proper oil level
Machine vibrates excessively	Pad not centered on pad driver	Remove pad and center pad properly on pad driver
	Pad damaged	Replace pad
	Loose bolts	Check and tighten bolts
	Pad center lock is loose	Tighten pad center lock securely
Machine is hard to push	Floor may be uneven in one spot	Try another spot on the floor
	Front end bearing housing not adjusted properly	Adjust the front end bearing housing
Machine pulls to the left	Floor may be uneven in one spot	Try another spot on the floor
	Front end bearing housing not adjusted properly	Adjust the front end bearing housing
Lacks power	Some type of engine problem	Refer to engine owner's manual and read IMPORTANT below
Nothing here fixes the problem	Problem could have several causes	Read IMPORTANT below

**IMPORTANT:** Propane fueled combustion engines produce dangerous gases and must be serviced by authorized service personnel trained specifically to service propane fueled engines and fuel systems. The troubleshooting tips are not intended to take the place of authorized service personnel. If you are unsure of what to do contact an authorized service personnel. Before working on this machine you must be familiar with the safety instructions in this manual.



# BETCO US WARRANTY POLICY

## 10 year coverage

Subject to the conditions stated below, Betco warrants parts and labor on rotationally molded polyethylene tanks/housings and injection molded vacuum head assemblies to be free from defects in materials and workmanship for a period of ten years to the original purchaser.

## 3 Year Coverage

Subject to the conditions stated below, Betco warrants parts and labor on all other Betco components to be free from defects in materials and workmanship for a period of three years to the original purchaser.

## 1 Year Coverage

Subject to the conditions stated below, Betco offers a limited warranty on parts and labor on the following equipment: parts and accessories to be free from defects in materials and workmanship for a period of one year to the original purchaser.

- DM Series Vacuums: #85506-00, #85507-00
- Bac Pac Lite Vacuum: #85903-00
- FiberPRO® Floor Dryer: #85507-00
- WORKMAN™ Series Vacuums: #85024-00, #85025-00, #85026-00, #85027-00
- CV100T Vacuum: #85023-00
- All Tools and Accessories
- All Battery Chargers
- All Batteries are pro-rated for 1 year

### **Allowable Travel Time Warranty Reimbursement:**

Eligible equipment: All battery and propane powered equipment products. Warranty period: 90 days from date of sale to the original purchaser. A maximum 60 mile round trip at 44 cents per mile will be allowed for warranty consideration.

### **Propane Machine Warranty:**

Honda engines are warranted by Honda for a period of 2 years against manufacturer defects. Kawasaki engines are warranted by Kawasaki for a period of 2 years against manufacturer defects. All other components (except wear items)\* are warranted by Betco for a period of 3 years.

**\*Wear Items exempt from Warranty consideration include but may not be limited to: power cords, transport wheels, vacuum bags, belts, squeegee blades, pad drivers, clutch plates, handle grips, filters, screens, throttle cables, brushes and carbon brushes.**

Subject to the conditions and exceptions stated in this warranty, Betco warrants the Betco products to be free from defects in material and workmanship, under normal use and service, for the periods listed under the warranty policy to the original purchaser. At any time during the warranty period, Betco will furnish replacement parts for the Betco parts to the original purchaser. Such parts will be furnished and charged including transportation costs, to the original owner through any Betco authorized Service Distributor. If the original part is returned within the warranty policy period from date of delivery for inspection by Betco and is found to be defective the owner will be credited for the cost of replacement parts plus shipping and handling. Replacement parts that have become defective through wear or abuse are not included in this warranty.

This warranty does not apply to damage or defect caused by accident, misuse, negligence, fire, or to any Betco product which has been serviced or repaired by other than an authorized Betco Service Distributor or Betco factory personnel. This warranty is void if products are used for any purpose other than that which was intended. There are no other warranties expressed or implied. In no event shall Betco be liable for incidental or consequential damages or any damage to person or property. (Please note some states do not allow the exclusion or limitations for incidental and consequential damages)

